

GARMIN[®]

GI 275[™] Pilot's Guide



SYSTEM OVERVIEW

FLIGHT INSTRUMENTS

EIS

NAVIGATION

HAZARD AVOIDANCE

AUTOPILOT

IVSI

ADDITIONAL FEATURES

APPENDICES

INDEX

© 2019-2024 Garmin Ltd. or its subsidiaries. All rights reserved.

This manual reflects the operation of the GI 275 system through main software version 3.20. Some differences in operation may be observed when comparing the information in this manual to earlier or later software versions.

Garmin International, Inc.

1200 East 151st Street
Olathe, Kansas 66062, U.S.A.

Garmin (Europe) Ltd.

Liberty House, Hounsdown Business Park
Southampton, Hampshire SO40 9LR U.K.

Garmin AT, Inc.

2345 Turner Road SE
Salem, OR 97302, U.S.A.

Garmin Corporation

No. 68, Zhangshu 2nd Road
Xizhi District, New Taipei City, Taiwan

**Contact Garmin Product Support or view warranty information at
flygarmin.com.**

Except as expressly provided herein, no part of this manual may be reproduced, copied, transmitted, disseminated, downloaded, or stored in any storage medium, for any purpose without the express written permission of Garmin. Garmin hereby grants permission to download a single copy of this manual and of any revision to this manual onto a hard drive or other electronic storage medium to be viewed for personal use, provided that such electronic or printed copy of this manual or revision must contain the complete text of this copyright notice and provided further that any unauthorized commercial distribution of this manual or any revision hereto is strictly prohibited.

Garmin®, SafeTaxi®, and MapSource® are registered trademarks of Garmin Ltd. or its subsidiaries. ANT+™, GI 275™, Smart Glide™ & PlaneSync™ are trademarks of Garmin Ltd. or its subsidiaries. These trademarks may not be used without the express permission of Garmin.

Jeppesen® is a registered trademark of Jeppesen, Inc. NavData™ is a trademark of Jeppesen, Inc. SiriusXM Weather is provided by SiriusXM Satellite Radio, Inc. The Bluetooth® word mark and logos are registered trademarks owned by Bluetooth SIG, Inc. and any use of such marks by Garmin is under license. This product is ANT+™ certified. Visit www.thisisant.com/directory for a list of compatible products and apps.

Printed in the U.S.A.





WARNING: Do not use Terrain information for primary terrain avoidance. Terrain information is intended only to enhance situational awareness.



WARNING: Always refer to current aeronautical charts and NOTAMs for verification of displayed aeronautical information. Displayed aeronautical data may not incorporate the latest NOTAM information.



WARNING: Do not use geometric altitude for compliance with air traffic control altitude requirements. The primary barometric altimeter must be used for compliance with all air traffic control altitude regulations, requirements, instructions, and clearances.



WARNING: Do not use Basemap information (land and water data) as the sole means of navigation. Basemap data is intended only to supplement other approved navigation data sources and should be considered only an aid to enhance situational awareness.



WARNING: Do not rely solely upon the display of traffic information to accurately depict all of the traffic within range of the aircraft. Due to lack of equipment, poor signal reception, and/or inaccurate information from aircraft or ground stations, traffic may be present that is not represented on the display.



WARNING: Do not use datalink weather information for maneuvering in, near, or around areas of hazardous weather. Information contained within datalink weather products may not accurately depict current weather conditions.



WARNING: Do not use the indicated datalink weather product age to determine the age of the weather information shown by the datalink weather product. Due to time delays inherent in gathering and processing weather data for datalink transmission, the weather information shown by the datalink weather product may be older than the indicated weather product age.



WARNING: Do not rely on the displayed minimum safe altitude (MSAs) as the sole source of obstacle and terrain avoidance information. Always refer to current aeronautical charts for appropriate minimum clearance altitudes.



WARNING: Do not operate this equipment without first obtaining qualified instruction.



WARNING: Do not use GPS to navigate to any active waypoint identified as a 'NON WGS84 WPT' by a system message. 'NON WGS84 WPT' waypoints are derived from an unknown map reference datum that may be incompatible with the map reference datum used by GPS (known as WGS84) and may be positioned in error as displayed.



WARNING: Do not rely on the Autopilot to level the aircraft at the minimum approach altitude when flying an approach with vertical guidance.



WARNING: Do not rely solely upon datalink services to provide Temporary Flight Restriction (TFR) information. Always confirm TFR information through official sources such as Flight Service Stations or Air Traffic Control.



WARNING: Do not use SafeTaxi[®] information as the primary method of flight guidance during ground operations. SafeTaxi[®] does not have NOTAM or ATIS information regarding the current active runway, condition, or complete information about the position of hold lines.



WARNING: Do not rely solely upon the display of traffic information for collision avoidance maneuvering. The traffic display does not under any circumstances or conditions relieve the pilot's responsibility to see and avoid other aircraft.



WARNING: Always use traffic information shown on system displays only as an aid to visually acquiring traffic. Traffic avoidance maneuvers are based upon Traffic Resolution Advisories, ATC guidance, or positive visual acquisition of conflicting traffic.



WARNING: Do not rely on the accuracy of heading indications in the following geographic areas (due to variations in the earth's magnetic field): North of 72° North latitude at all longitudes; South of 70° South latitude at all longitudes; North of 65° North latitude between longitude 75° W and 120° W. (Northern Canada); North of 70° North latitude between longitude 70° W and 128° W. (Northern Canada); North of 70° North latitude between longitude 85° E and 114° E. (Northern Russia); South of 55° South latitude between longitude 120° E and 165° E. (Region south of Australia and New Zealand).



WARNING: Do not rely on information from a lightning detection system display as the sole basis for hazardous weather avoidance. Range limitations and interference may cause the system to display inaccurate or incomplete information. Refer to documentation from the lightning detection system manufacturer for detailed information about the system.



WARNING: Use appropriate primary systems for navigation, and for terrain, obstacle, and traffic avoidance. Garmin SVT is intended as an aid to situational awareness only and may not provide either the accuracy or reliability upon which to solely base decisions and/or plan maneuvers to avoid terrain, obstacles, or traffic.



WARNING: Do not use the Garmin SVT runway depiction as the sole means for determining the proximity of the aircraft to the runway or for maintaining the proper approach path angle during landing.



CAUTION: Do not clean display surfaces with abrasive cloths or cleaners containing ammonia. They will harm the anti-reflective coating.



CAUTION: Do not allow repairs to be made by anyone other than an authorized Garmin service center. Unauthorized repairs or modifications could void both the warranty and affect the airworthiness of the aircraft.



NOTE All visual depictions contained within this document, including screen images, are subject to change and may not reflect the most current system and aviation databases. Depictions of equipment may differ slightly from the actual equipment.



NOTE: Refer to the current, pertinent flight manual for operational conditions and alert/advisory corrective procedures.



NOTE: The United States government operates the Global Positioning System and is solely responsible for its accuracy and maintenance. The GPS system is subject to changes which could affect the accuracy and performance of all GPS equipment. Portions of the system utilize GPS as a precision electronic NAVigation AID (NAVAID). Therefore, as with all NAVAIDs, information presented by the system can be misused or misinterpreted and, therefore, become unsafe.



NOTE: This device complies with part 15 of the FCC Rules. Operation is subject to the following two conditions: (1) this device may not cause harmful interference, and (2) this device must accept any interference received, including interference that may cause undesired operation. **Anatel Warning:** Este equipamento não tem direito a proteção contra interferência prejudicial e não pode causar interferências em sistemas devidamente autorizados.



NOTE: Interference from GPS repeaters operating inside nearby hangars can cause an intermittent loss of attitude and heading displays while the aircraft is on the ground. Moving the aircraft more than 100 yards away from the source of the interference should alleviate the condition.



NOTE: Use of polarized eyewear may cause the Multi-Function Instrument (MFI) to appear dim or blank.



NOTE: This product, its packaging, and its components contain chemicals known to the State of California to cause cancer, birth defects, or reproductive harm. This notice is being provided in accordance with California's Proposition 65. If you have any questions or would like additional information, please refer to our web site at www.garmin.com/prop65.



NOTE: Operating the system in the vicinity of metal buildings, metal structures, or electromagnetic fields can cause sensor differences that may result in nuisance miscompare annunciations during start up, shut down, or while taxiing. If one or more of the sensed values are unavailable, the annunciation indicates no comparison is possible.



NOTE: The internal GPS is only for VFR use.



NOTE: Terrain and obstacle alerting is not available north of 89° North latitude and south of 89° South latitude. This is due to limitations present within the Terrain database and the system's ability to process the data representing the affected areas.



NOTE: The nose of the 'own ship' symbol represents the location of the aircraft. The center of any traffic symbol represents the location of that traffic. The traffic and own ship symbols are an abstract representation and do not reflect the physical extent of the aircraft/traffic, and should not replace other methods for identifying traffic.



NOTE: Traffic surveillance is not available during the system test. Use caution when performing a system test during flight.



NOTE: During system startup, if the Autopilot is engaged (though not typical), the MFI will automatically disengage the Autopilot when the sensors initiate alignment at startup.



NOTE: The wireless card on the MFI may take up to two minutes before wireless functionality is available.



NOTE: The system responds to a terminal procedures based on data coded within that procedure in the Navigation Database. Differences in system operation may be observed among similar types of procedures due to differences in the Navigation Database coding specific to each procedure.



NOTE: The FAA has asked Garmin to remind pilots who fly with Garmin database-dependent avionics of the following:

- It is the pilot's responsibility to remain familiar with all FAA regulatory and advisory guidance and information related to the use of databases in the National Airspace System.
- Garmin equipment will only recognize and use databases that are obtained from Garmin or Jeppesen. Databases obtained from Garmin or Jeppesen that have a Type 2 Letter of Authorization (LOA) from the FAA are assured compliance with all data quality requirements (DQRs). A copy of the Type 2 LOA is available for each applicable database and can be viewed at flygarmin.com by selecting 'Aviation Database Declarations.'

- *Use of a current Garmin or Jeppesen database in your Garmin equipment is required for compliance with established FAA regulatory guidance, but does not constitute authorization to fly any and all terminal procedures that may be presented by the system. It is the pilot's responsibility to operate in accordance with established pertinent aircraft documents and regulatory guidance or limitations as applicable to the pilot, the aircraft, and installed equipment.*
-



NOTE: *The pilot/operator must review and be familiar with Garmin's database exclusion list as discussed in SAIB CE-14-04 to determine what data may be incomplete. The database exclusion list can be viewed at flygarmin.com by selecting 'Database Exclusions List.'*



NOTE: *The pilot/operator must have access to Garmin and Jeppesen database alerts and consider their impact on the intended aircraft operation. The database alerts can be viewed at flygarmin.com by selecting 'Aviation Database Alerts.'*



NOTE: *Garmin requests the flight crew report any observed discrepancies related to database information. These discrepancies could come in the form of an incorrect procedure; incorrectly identified terrain, obstacles and fixes; or any other displayed item used for navigation or communication in the air or on the ground. Go to flygarmin.com and select 'Aviation Data Error Report.'*



NOTE: *Although the Jeppesen Navigation Database and the Garmin Navigation Database contain much of the same information, pilots may notice differences in behavior, nearest list functionality, direct-to functionality, and 'Map' Page display due to data content variations.*



NOTE: *Some data contained in the terrain and obstacle databases comes from government agencies. Garmin accurately processes and cross-validates the data, but cannot guarantee the accuracy and completeness of the data.*



NOTE: *After performing a navigation database update, cross check with any external navigator which is providing flight plan data and verify all flight plan(s) (routes) are current. If there is an obsolete aviation point in a saved route, the route is locked and unusable. A new route with current navigation database points will need to be created.*

Blank Page

SOFTWARE LICENSE AGREEMENT

BY USING THE DEVICE, COMPONENT OR SYSTEM MANUFACTURED OR SOLD BY GARMIN ("THE GARMIN PRODUCT"), YOU AGREE TO BE BOUND BY THE TERMS AND CONDITIONS OF THE FOLLOWING SOFTWARE LICENSE AGREEMENT. PLEASE READ THIS AGREEMENT CAREFULLY. Garmin Ltd. and its subsidiaries ("Garmin") grants you a limited license to use the software embedded in the Garmin Product (the "Software") in binary executable form in the normal operation of the Garmin Product. Title, ownership rights, and intellectual property rights in and to the Software remain with Garmin and/or its third-party providers. You acknowledge that the Software is the property of Garmin and/or its third-party providers and is protected under the United States of America copyright laws and international copyright treaties. You further acknowledge that the structure, organization, and code of the Software are valuable trade secrets of Garmin and/or its third-party providers and that the Software in source code form remains a valuable trade secret of Garmin and/or its third-party providers. You agree not to reproduce, decompile, disassemble, modify, reverse assemble, reverse engineer, or reduce to human readable form the Software or any part thereof or create any derivative works based on the Software. You agree not to export or re-export the Software to any country in violation of the export control laws of the United States of America.

Blank Page

| Part Number | Rev | Date | Description |
|--------------|-----|-----------------|---|
| 190-02246-01 | Q | April, 2024 | Updated to reflect software version 3.20 Updated Standby Battery Test Details Updated CDI Sync Updated Database Sync Options Added Single Cylinder CHT/EGT Display Added 7 Cylinder CHT/EGT Display |
| | P | December, 2023 | Updated to reflect software version 3.10 Vne Barber Pole Style Airspeed Markings Configuration for Minimum Airspeed Come-alive Value EGT/CHT Single Cylinder Engine Support Enhanced Mis-compare Alerts for 3 Sensor Systems Enhanced No-compare Alerts ILS Only Configuration for NAV Interface |
| | N | September, 2023 | Corrected Clerical Error |
| | M | July, 2023 | Updated to reflect software version 3.01 Enhanced CHT/EGT Functionality Enhanced Sensor Logic Enhanced ESP Functionality G-Meter Added to Misc. Field GDL 60 Support |
| | L | November, 2022 | Updated to reflect software version 2.60 Enhanced Misc. Field Functionality Enhanced SYNC Control Functionality |
| | K | July, 2022 | Updated to reflect software version 2.53 |
| | J | April, 2022 | Updated to reflect software version 2.50 Enhanced Database Update Process Dual Cue Flight Director Functionality Carburetor Temp Guage Details MACH Airspeed Display Option |
| | H | January, 2022 | Updated to reflect software version 2.42 Updated Reversionary Info Selected Altitude Intercept Arc Enhanced AUX Fuel Display |

| | | | |
|--------------|---|-----------------|--|
| | G | July, 2021 | Updated to reflect software version 2.40 Enhanced EIS Functionality Smart Glide |
| | F | April, 2021 | Updated to reflect software version 2.30 Enhanced Transponder Functionality |
| | E | January, 2021 | Corrected Clerical Error |
| | D | December, 2020 | Updated to reflect software version 2.20 |
| | C | December, 2020 | Instantaneous Vertical Speed Indicator Enhanced Rotorcraft Features Glove Qualification |
| | B | August, 2020 | Enhanced USB Functionality Enhanced Fast Database Sync Enhanced ADI Options Enhanced MFD Functionality GFC 500 Integration |
| 190-02246-01 | A | September, 2019 | Production Release |

| | |
|---|-----------|
| SECTION 1 SYSTEM OVERVIEW | 1 |
| 1.1 INSTRUMENT DESCRIPTION | 1 |
| 1.2 UNIT TYPES AND CONFIGURATIONS | 2 |
| Unit Types | 2 |
| Unit Configurations | 3 |
| 1.3 CONTROLS | 4 |
| ADI Depiction | 6 |
| Touchscreen | 7 |
| Page Navigation | 7 |
| Control Types | 8 |
| Page Menus | 9 |
| Menu Navigation | 10 |
| Data Entry | 10 |
| 1.4 OPERATION | 11 |
| Instrument Power Application | 11 |
| Normal Operation | 11 |
| Reversionary Operation | 12 |
| System Annunciations | 12 |
| Backup Battery | 13 |
| ADAHRS Operation (Optional) | 15 |
| VFR GPS Receiver Operation | 17 |
| 1.5 ACCESSING SYSTEM FUNCTIONALITY | 20 |
| System Settings | 20 |
| 1.6 DISPLAY BACKLIGHTING | 23 |
| 1.7 DEVICE REGISTRATION | 24 |
| 1.8 WIRELESS CONNECTIVITY (GARMIN CONNEXT) | 25 |
| Bluetooth Setup | 26 |
| Managing Paired Devices | 28 |
| 1.9 DATABASES | 30 |
| Automatic Database Updates | 32 |
| Database Sync Options | 32 |
| Manually Updating Databases | 33 |

| | |
|--|-----------|
| SECTION 2 FLIGHT INSTRUMENTS | 37 |
| 2.1 FLIGHT INSTRUMENTS | 37 |
| Attitude Indicator | 37 |
| Airspeed Indicator | 38 |
| Altimeter | 40 |
| Altimeter (GSL Backup)..... | 42 |
| Vertical Speed Indicator (VSI) | 43 |
| Heading Indicator | 43 |
| Deviation Indicators | 44 |
| OBS Mode | 50 |
| SYNC Control | 51 |
| HSI (Horizontal Situation Indicator) Page Features | 55 |
| 2.2 ANNUNCIATIONS AND ALERTING FUNCTIONS | 57 |
| Altitude Alerting | 57 |
| Minimum Altitude Alerting | 57 |
| 2.3 ABNORMAL OPERATIONS | 58 |
| Abnormal GPS Conditions | 58 |
| Comparator Annunciations | 59 |
| Loss of Primary Flight Information..... | 60 |
| AHRS Failure | 61 |
| Reversionary Sensor Annunciations | 61 |
| Unusual Attitudes | 62 |
| Smart Glide Activation..... | 64 |
| SECTION 3 ENGINE INDICATION SYSTEM | 65 |
| 3.1 INTRODUCTION | 65 |
| Start-Up Screen..... | 66 |
| 3.2 GAUGE AND INDICATOR TYPES | 66 |
| Bar Graph Indications..... | 70 |
| Percent Power Indications | 71 |
| Multi-Engine Indications | 71 |
| 3.3 EIS PAGES | 71 |
| Main Page | 72 |
| AUX Page..... | 76 |
| CHT/EGT Page | 78 |

| | |
|--|------------|
| Flight Summary Page..... | 89 |
| Fuel Page..... | 92 |
| 3.4 ABNORMAL OPERATIONS | 95 |
| EIS Alerts..... | 95 |
| SECTION 4 NAVIGATION | 97 |
| 4.1 INTRODUCTION..... | 97 |
| 4.2 MAP DATA..... | 97 |
| Map Range..... | 97 |
| Map Symbols..... | 99 |
| Map Detail..... | 102 |
| Map Options - Primary HSI..... | 104 |
| Map Options - Standby ADI / MFD..... | 109 |
| Map Panning..... | 128 |
| 4.3 DIRECT TO AND FLIGHT PLAN NAVIGATION..... | 131 |
| Direct To Navigation..... | 131 |
| Flight Plan / Direct To Navigation From External Source..... | 134 |
| Navigation Data Displayed on Map..... | 135 |
| MFD Data..... | 137 |
| Flight Plan Sharing..... | 138 |
| 4.4 ABNORMAL OPERATIONS | 138 |
| Abnormal GPS Conditions..... | 138 |
| SECTION 5 HAZARD AVOIDANCE | 141 |
| 5.1 INTRODUCTION..... | 141 |
| 5.2 DATALINK WEATHER | 141 |
| Datalink Weather Products..... | 144 |
| Weather Product Age..... | 161 |
| Display of Weather Products..... | 163 |
| 5.3 STORMSCOPE LIGHTNING DETECTION SYSTEM..... | 166 |
| Stormscope Options..... | 166 |
| 5.4 TERRAIN..... | 168 |
| Displaying Terrain Data..... | 172 |
| Terrain Alerts..... | 174 |
| Terrain Inhibit..... | 179 |

| | |
|--|------------|
| Terrain Status | 179 |
| Synthetic Vision Terrain | 180 |
| 5.5 TRAFFIC..... | 181 |
| Display of Traffic Information..... | 182 |
| Traffic Data by Source | 187 |
| SECTION 6 AUTOPILOT | 199 |
| 6.1 OVERVIEW..... | 199 |
| 6.2 FLIGHT CONTROL..... | 200 |
| Pitch Axis and Trim | 200 |
| Roll Axis | 200 |
| Yaw Axis | 200 |
| 6.3 AUTOPILOT OPERATION | 200 |
| Command Bars | 200 |
| Engaging the Autopilot..... | 202 |
| Disengaging the Autopilot | 203 |
| 6.4 GARMIN GFC 500 AUTOPILOT (OPTIONAL) | 204 |
| GFC 500 AFCS Configuration | 204 |
| GMC 507 Mode Controller..... | 205 |
| GSA 28 Servo..... | 205 |
| 6.5 AFCS SYSTEM ARCHITECTURE..... | 206 |
| GI 275 AFCS Status Box..... | 206 |
| AFCS Operation | 206 |
| GMC 507 Controls..... | 207 |
| Engaging The Autopilot..... | 208 |
| Disengaging The Autopilot | 209 |
| Overpowering Autopilot Servos | 209 |
| Vertical Modes | 212 |
| Lateral Modes..... | 219 |
| 6.6 GFC 500 AFCS ALERTS..... | 226 |
| Trim Alerts..... | 226 |
| Speed Alerts | 226 |
| GFC 500 Messages And Annunciations | 227 |

| | |
|---|------------|
| 6.7 ELECTRONIC STABILITY & PROTECTION (ESP) (GFC 500) | 227 |
| Roll Engagement..... | 229 |
| Pitch Engagement..... | 229 |
| Airspeed Protection (GFC 500 Only)..... | 230 |
| SECTION 7 INSTANTANEOUS VERTICAL SPEED INDICATOR..... | 231 |
| 7.1 OVERVIEW..... | 231 |
| 7.2 Vertical Speed / RA Display | 231 |
| 7.3 Resolution Advisories | 231 |
| 7.4 Traffic Display..... | 232 |
| 7.5 Controls and Annunciations | 235 |
| 7.6 Altitude Filtering | 236 |
| 7.7 Altitude Type | 236 |
| 7.8 Traffic Collision Avoidance System (TCAS) Mode | 237 |
| 7.9 Failure Annunciations..... | 237 |
| SECTION 8 ADDITIONAL FEATURES..... | 241 |
| 8.1 OVERVIEW..... | 241 |
| 8.2 SAFETAXI®..... | 241 |
| 8.3 RADAR ALTIMETER (OPTIONAL) | 244 |
| Overview..... | 244 |
| Radar Altimeter Test..... | 248 |
| 8.4 FLIGHT DATA LOGGING..... | 249 |
| Wireless Flight Data Logging With ConnexT..... | 249 |
| Exporting Flight Data With a USB Drive..... | 249 |
| Data Parameters | 250 |
| 8.5 GARMIN PILOT WATCH CONNECTIVITY (OPTIONAL)..... | 252 |
| 8.6 SYNTHETIC VISION TECHNOLOGY (SVT™) (OPTIONAL)..... | 254 |
| SVT Features..... | 256 |
| SVT Troubleshooting..... | 261 |
| Flight ID | 261 |
| 8.7 ADI AND HSI - MISC. FIELD (OPTIONAL)..... | 262 |

| | |
|--|------------|
| 8.8 TRANSPONDER CONTROL (OPTIONAL) | 266 |
| Transponder Operation | 266 |
| Select Transponder | 266 |
| Ident | 267 |
| Standby | 267 |
| On | 267 |
| Altitude Reporting | 267 |
| VFR | 268 |
| Selecting a Squawk Code | 268 |
| GDL 60 (OPTIONAL) | 270 |
| PlaneSync™ | 270 |
| Remote Aircraft Status | 271 |
| LS Only Configuration (Optional) | 272 |
| SECTION 9 APPENDICES | 273 |
| APPENDIX A: ANNUNCIATIONS, ALERTS AND GLOVE QUALIFICATION | 273 |
| Alert Level Definitions | 273 |
| System Messages | 275 |
| Glove Qualification | 279 |
| APPENDIX B: DATABASE INFORMATION | 285 |
| Available Databases | 286 |
| Database Troubleshooting Tips | 287 |
| APPENDIX C: AVIATION TERMS AND ACRONYMS | 289 |
| APPENDIX D: DISPLAY SYMBOLS | 307 |
| VFR Symbols | 307 |
| IFR Symbols | 308 |
| Airspace Symbols | 309 |
| INDEX | I-1 |

SECTION 1 SYSTEM OVERVIEW



NOTE: All visual depictions contained within this document, including screen images, are subject to change and may not reflect the most current system and aviation databases. Depictions of equipment may differ slightly from the actual equipment.

1.1 INSTRUMENT DESCRIPTION

The GI 275 Multi-Function Instrument (MFI) is a highly configurable drop-in upgrade for many traditional round-gauge instruments. The MFI can relay information to and process data from compatible devices in the following categories for fixed wing and rotorcraft configurations:

- Primary Flight Displays (PFDs)
 - The MFI can synchronize certain parameters with compatible PFDs.
 - Compatible PFDs can provide database updates to the MFI.
- Air Data Computers (ADC)
 - The MFI can receive, process, and relay data from compatible air data computers.
- Attitude and Heading Reference Systems (AHRS)
 - The MFI can receive, process, and relay data from compatible attitude and heading reference systems.
- Autopilot System (Fixed wing only)
 - The MFI with autopilot interface can send course deviation and attitude data to a compatible autopilot system.
 - Refer to the Autopilot Section for more information.
- GPS Navigators and/or VOR NAV Radios
 - The MFI can receive course deviation information from compatible GPS or NAV sources.
 - Compatible Garmin navigators can provide database updates to the MFI.
 - In the event that no external GPS sources exist or all configured external GPS sources fail, the MFI can revert to its internal VFR GPS for navigation.
- Transponders
 - ADS-B In transponders can provide traffic and weather data to the MFI.
 - The MFI may act as an altitude source for altitude-reporting transponders.
 - The MFI can provide transponder control for the GTX 345.

System Overview

Flight Instruments

EIS

Navigation

Hazard Avoidance

Autopilot

IVSI

Additional Features

Appendices

Index

- Engine-Airframe Interfaces (Fixed wing only)
 - The MFI can display engine data from compatible engine-airframe interfaces.
- Magnetometers
 - The MFI can display magnetic heading data from compatible magnetometers.
- Outside Air Temperature Probes
 - The MFI can use outside air temperature probes to determine true airspeed.
- Radar/Radio Altimeters
 - The MFI can display altitude above the ground (radio/radar altitude) from a compatible radar/radio altimeter.
- Traffic Awareness System (TAS) or Traffic Collision Avoidance System (TCAS)
 - The MFI can display traffic information from TAS or TCAS units independent of the air traffic control system.
- GDL 69 SXM
 - The MFI can display SiriusXM weather information (subscription required) from the SiriusXM Datalink Receiver.
- Stormscope®
 - The MFI can display lightning information from a Stormscope® unit.
- GSB 15
 - The MFI can receive database and software updates through the GSB 15.
- Instantaneous Vertical Speed Indicator (IVSI)
 - The MFI can display Vertical Speed indication with traffic and resolution advisory indications from a compatible TCAS II source.
- GI 275
 - Multiple MFIs can work in conjunction with each other to display more information or act as backups in the unlikely event an MFI unit fails.

1.2 UNIT TYPES AND CONFIGURATIONS

UNIT TYPES

Basic

The basic model of the MFI can act as an attitude indicator (ADI), horizontal situation indicator (HSI), engine indication system (EIS), or multi-function display (MFD).

To act as an attitude indicator, the basic MFI must have an external AHRS source. To display air data, the basic MFI must have an external air data computer. To show magnetic heading, all MFIs must have an external magnetometer.

The basic version with an NVIS friendly encoder halo light is available, which provides the 'green' tint backlit knob

With Internal ADAHRS (Air Data and Attitude and Heading Reference System)

The MFI with internal ADAHRS can do everything the basic MFI does and additionally contains its own air data and AHRS source, as well as interface to Garmin's fixed wing GFC 500 or GFC 600 autopilot, saving weight and expense.

An ADAHRS version with an NVIS friendly encoder halo light is available, which provides the 'green' tint backlit knob.

With Internal ADAHRS and Autopilot Interface

For fixed wing installations, the MFI with autopilot interface expands the MFI with internal ADAHRS capability and has interfaces to connect to an external autopilot or AFCS, letting the MFI provide heading/course error and attitude to compatible autopilot and AFCS devices.

UNIT CONFIGURATIONS

Primary ADI

A Primary ADI replaces the traditional attitude indicator. It may additionally show airspeed, altitude, vertical speed, and heading. Terrain is displayed with the optional SVT enablement.

Standby ADI or MFD

Standby ADI or MFD units provide additional capability to the aircraft and display information (e.g., maps) or external data (e.g., radar altimeter). Standby ADI units act as a backup ADI if the Primary ADI fails or the pilot reverts the display.

Primary HSI

The Primary HSI displays course deviation information based on the selected NAVAID. An HSI Map shows course deviation information overlaid on a map centered around the aircraft's current GPS position.

Standby HSI

The Standby HSI acts as a Primary HSI under normal conditions but as a backup ADI if a Primary ADI fails.

EIS

For fixed wing installations, EIS units replace traditional mechanical engine instruments and additional information like engine temperatures and provide features like engine lean assisting.

1.3 CONTROLS

The MFI features a 3.125" circular capacitive touchscreen and a Large and Small Knob in the lower left corner. The Small Knob can be pushed. All operations are done with the knobs or touchscreen. The touchscreen can be operated with bare fingers or gloves made for capacitive touchscreens.

- System Overview
- Flight Instruments
- EIS
- Navigation
- Hazard Avoidance
- Autopilot
- WSI
- Additional Features
- Appendices
- Index



GI 275 Controls ('ADI' Page)



GI 275 Controls - Aircraft Symbol Change ('ADI' Page)



GI 275 Controls - Aircraft Symbol Change - MACH

Selected Course



Selected Course Guidance



Selected Course

Course Guidance

Selected Course Guidance



NOTE: The Selected Course (CRS) feature requires installer configuration. When configured, the green Course Guidance arrow will be visible for five (5) seconds.

ADI DEPICTION



NOTE: Changing the ADI Depiction is only available if configured as pilot selectable.

Changing the ADI depiction between the Chevron and Standard aircraft symbol is a task the User can complete easily.

Changing the ADI Depiction:

- 1) Turn the Large Knob to navigate to the ADI page.
- 2) Open the **Menu > Options > ADI ACFT Symbol**.
- 3) Touch the desired Aircraft Symbol, either **Chevron** or **Standard**. The ADI Depiction will now be displayed.



Touch to View
Touch to Select



Changing ADI Depiction



Touch to Select



Changing ADI Depiction Cont'd

TOUCHSCREEN

| Gestures | |
|----------------------------|---|
| Touch | Touch is touching the screen briefly with a single finger. A touch can select a menu, activate a command key or data entry field, display map feature information, or select a button. |
| Touch and Hold | Certain momentary controls (e.g., directional arrow keys, CRS Button, HDG Button, Back Button) provide a secondary touch and hold function. Touch key and hold finger in place. Lift up once the desired action occurs. Use this gesture for scrolling, increasing/decreasing values continuously, and when using the Back Button to quickly back out to the top level. |
| Swipe | Touch object with finger, slide finger across screen, then lift up. A swipe is a smooth motion used for viewing and scrolling lists, panning across a map, or opening the menu. |
| Scroll | This is similar to a swipe, except the finger leaves the screen after a quick upward or downward motion. Screen information moves at a fast speed, then slows down as it stops. Scrolls through an item list faster than by pressing the scroll arrow buttons. |
| Pinch & Stretch | Touch any map with two fingers at the same time. Then, bring fingers together (pinch) or apart (stretch). Stretch to zoom in and pinch to zoom out. Use these gestures to magnify map features or identify multiple objects in proximity. |

PAGE NAVIGATION

A page navigation bar is displayed on the top portion of pages/indicators when the Large Knob is adjusted. The text shows the name of the active page, and the circles on the bottom of the bar indicate where in the list the current page is located. Additionally, a knob function legend is displayed.

Changing pages:

Turn the Large Knob clockwise to navigate to a page on the right or counterclockwise to navigate to a page on the left. For units with an 'ADI' Page, a rapid Large Knob counterclockwise turn will immediately navigate to the 'ADI' Page.

CONTROL TYPES

Annunciator Buttons

Annunciator buttons operate in an on/off state. An 'on' or enabled button displays a green annunciator; an 'off' or disabled button displays a subdued annunciator. Touch the annunciator button to change its state.



On or Enabled



Off or Disabled

Annunciator Buttons

Data Field Buttons

Data field buttons can be modified based on information the pilot can enter or change, and often contain cyan alphanumeric text. Touching data field buttons will either display a pop-up window from which a selection can be made or display a keypad to supply the data. See the Data Entry discussion in this section for more information.



Data Field Button

Sliders

Some adjustments are made using horizontal or vertical sliders. To use, touch within the slider box and slide the finger in the desired slider bar direction, then release the finger; or, turn the Small Knob. The finger may move outside of the slider box during adjustment; slider movement stops when either the finger is released, or the slider has reached its maximum travel. Some adjustments can be done using the arrow keys underneath or next to the slider.



Map Detail and Click Volume Slider

PAGE MENUS

It may be necessary to open menus to access specific features.

Opening the menu:

With any page displayed, swipe up starting at the bottom of the screen.

Or:

With any page displayed, push and hold the Small Knob.

Closing the menu:

From the menu, repeatedly touch the **Back** Button until the original page is displayed.

Or:

From the menu, touch and hold the **Back** Button.

Or:

From the menu, push and hold the Small Knob.

Or:

On ADI, HSI, and EIS units with a half-screen menu, touch the screen anywhere off the menu.

- System Overview
- Flight Instruments
- EIS
- Navigation
- Hazard Avoidance
- Autopilot
- WSI
- Additional Features
- Appendices
- Index

MENU NAVIGATION

Various menu items may be located under other menu items. It may be necessary to go through a few levels of intuitively organized menus to access desired functionality.

Selecting a menu item:

- 1) From the menu, scroll (side to side on units configured as primary ADI, HSI, EIS; up and down on other configurations with full-screen menu) to find the desired button.
- 2) Touch the desired button to select or toggle the highlighted item.

Or:

- 1) Turn the Large Knob to move the selection highlight and scroll through the menu.
- 2) Push the Small Knob to select or toggle the highlighted item.

DATA ENTRY

Data can be entered by using the touchscreen or knobs.

Entering data:

- 1) Select a data field button. The keypad is displayed.
- 2) Touch the desired letters and/or numbers.
- 3) To enter a negative number, first input the positive value. Then, touch the +/- Button to toggle the negative sign.
- 4) Touch the **Enter** Button to save input.

Or:

- 1) With the keypad displayed, turn the Small Knob to activate the cursor and enter the first letter and/or number. Turn the Small Knob clockwise to increase and counterclockwise to decrease.
- 2) Turn the Large Knob to move the cursor to the next character position (if applicable).
- 3) Repeat steps as necessary.
- 4) Push the Small Knob to save input.

Or:

- 1) Highlight a numerical data field with the Large Knob.
- 2) Turn the Small Knob clockwise to increase the numerical value, or counterclockwise to decrease the numerical value.

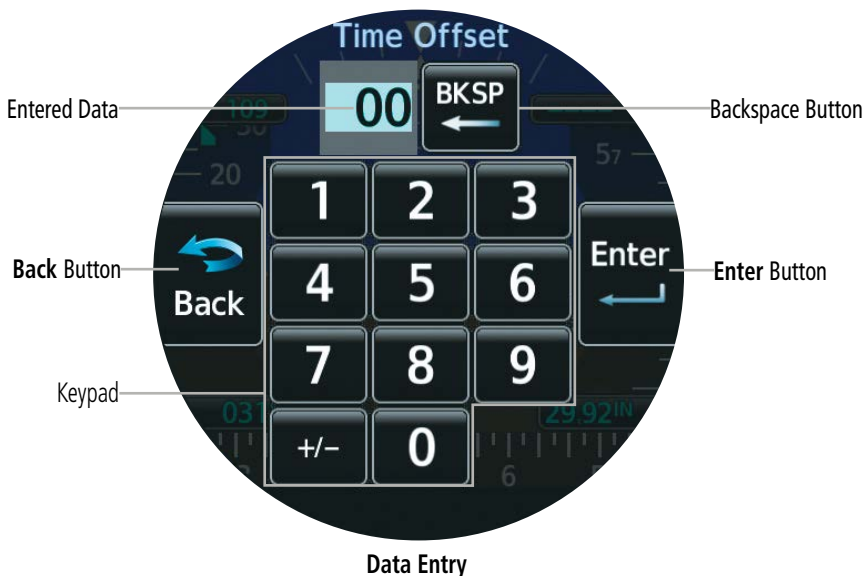

1.4 OPERATION



WARNING: Do not operate this equipment without first obtaining qualified instruction.



CAUTION: Do not clean display surfaces with abrasive cloths or cleaners containing ammonia. They will harm the anti-reflective coating.

INSTRUMENT POWER APPLICATION

Depending on the installation and aircraft electrical system, MFIs can be powered by either the aircraft's Battery or Avionics master.

NORMAL OPERATION



NOTE: All map and terrain data provided is only to be used as a general reference to your surroundings and as an aid to situational awareness. The VFR GPS navigation is intended to be used in VFR flight only.

Units configured as a Primary ADI

Units configured as a Primary ADI for fixed wing or rotorcraft only have an 'ADI' Page.

Units configured as a Standby ADI or MFD

Depending on configuration, the following pages are available:

- ADI
- CDI
- HSI
- HSI Map
- Traffic
- Terrain
- Map
- MFD Data
- Stormscope
- Radar Altimeter
- SXM Weather
- FIS-B Weather
- Main EIS
- Aux EIS
- Aux Fuel
- EGT
- CHT
- Fuel
- Transponder Control

Units configured as an EIS

Depending on configuration, the following pages are available:

- Main
- AUX
- EGT
- CHT
- Fuel

Units configured as a Primary HSI

Depending on configuration, the following pages are available:

- HSI
- HSI Map

Units configured as a Standby HSI

Depending on configuration, the following pages are available:

- ADI
- HSI
- HSI Map

REVERSIONARY OPERATION

When a unit configured as a Standby ADI or Standby HSI detects compatible interconnected instruments (another MFI, G500/600 TXi, etc.) have a fault, the unit exclusively behaves as a Primary ADI until the fault is resolved. Alternatively, the crew can manually select reversionary operation modes from panel-mounted switches (if installed), i.e. the rotation of the outer knob counter-clockwise or engages the reversionary switch.

SYSTEM ANNUNCIATIONS

If a major component of the instrument system has failed, a red or yellow 'X' may be displayed.



Red or Yellow 'X' Annunciations Indicate System Component Failure

Failure Annunciators Example

Message Alert Indicator

When a new message is issued, the Message Alert Indicator flashes to alert the flight crew. It continues to flash until acknowledged by viewing the 'Messages' Screen, accessed through the menu. Active messages are displayed on the 'Messages' Screen in white text. The Message Alert Indicator flashes again if the state of an acknowledged message changes or a new message is displayed. Each message will remain listed until the condition of the message is resolved, or a power cycle is completed. If multiple MFIs are installed, each unit will independently generate its own messages; messages are not synchronized across units. Thus, the flight crew must acknowledge messages on each MFI.



Message Alert Indicator

BACKUP BATTERY



NOTE: *If installed, the backup battery provides 60 minutes of power.*

When on the ground and aircraft power is lost, an "External power lost. Shutting down in x" countdown begins with an option to Stay On or Pwr Off. The unit must be manually shut down after aircraft power is lost and the Stay On Button is selected. If airborne and power is lost, an "External power lost." message is displayed.



NOTE: While the unit operates on the backup battery, certain data may not be available.

The battery must be tested every 392 days by an authorized mechanic using the instructions provided in the Installation Manual for legal flight under IFR.

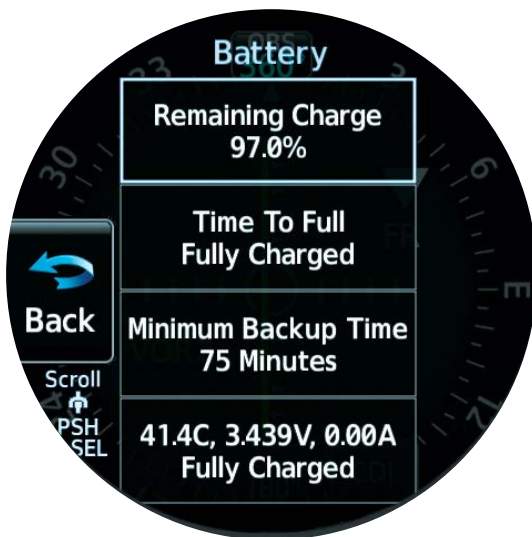

Battery 'Menu'

The 'Battery Status' Screen displays:

- Remaining battery charge %
- Time to full charge (if charging)
- Minimum battery backup time
- Battery status (temperature, voltage, current)

Viewing backup battery status:

From any page, open the menu and select **System > Battery**.

Turning off the MFI when the backup battery is installed:

From any page, open the menu and select **System > Power**.

Turning on the MFI when the backup battery is installed:

Push the Small Knob.



Battery - Power-Off Menu

Status Annunciations

Battery status annunciations appear on the upper left portion of the MFI.

| Annunciation(s) | Explanation |
|-----------------|---|
| | System running on battery / battery charging Greater than or equal to 60 minutes of battery life |
| | System running on battery / battery charging Between 15 - 59 minutes of battery life |
| | Battery fault or battery rundown test expired |
| | System running on battery / battery charging Less than 15 minutes of battery life |

ADAHRS OPERATION (OPTIONAL)

The Air Data and Attitude and Heading Reference System (ADAHRS or AHRS/ADC) displays aircraft attitude, airspeed, altitude, and heading information. This data can be pulled from internal or external sensors. Heading can be displayed on the ADI page and/or the HSI/HSI Map page.

AHRS

During system initialization, the AHRS displays the message 'AHRS ALIGN, KEEP WINGS LEVEL' over the attitude indicator. If a heading indicator is configured, a red 'X' will be displayed until the instrument receives valid heading data. The AHRS should display valid attitude and heading fields typically within the first minute of power application.

The AHRS can align itself both during flight and while taxiing. The realign can occur provided the MFI is restarted while in straight and level flight or while taxiing in straight and level conditions (+/- 5 ° pitch, +/- 10° roll). When realigning, the ADI's attitude information is removed and replaced with an annunciation instructing the pilot to attempt to maintain straight and level flight. Depending on the conditions, airborne and taxiing alignments are usually successful within 1-2 minutes.

Heading

Heading indications are corrected for shifts and variations in the Earth's magnetic field by applying the Magnetic Field Variation Database. The Magnetic Field Variation Database is derived from the International Geomagnetic Reference Field (IGRF). The IGRF is a mathematical model that describes the Earth's main magnetic field and its annual rate of change. The database is updated approximately every 5 years through a Navigation database update. Failure to update this database could lead to erroneous heading information being displayed to the crew.

Any failure of the AHRS sensors results in loss of attitude and heading information and failure of ADC sensors results in loss of air data information (indicated by red 'X' flags over the corresponding flight instruments). If the MFI senses the magnetic heading measurement is valid, but possibly outside of the internal accuracy limits, the numeric heading value will be displayed in yellow.

If the magnetometer input fails, the heading output is flagged as invalid with a red 'X' but track information is displayed instead if valid GPS data are available.

In installations that include multiple air data and AHRS units (MFI supports up to two external air data and AHRS sources in addition to the internal ADAHRS source if equipped), if data from an air data or AHRS source is lost, the MFI can display data from alternate sources. A data failure condition is annunciated by 'X's over instruments, miscompare flags, or no compare flags. Data source switching is not automatic. Reversionary sensor selection is annunciated near the relevant data field or at the top of the display.

Manually switching AHRS or ADC sensors:

- 1) From the 'ADI' Page, open the menu.
- 2) Select the **ADI Options** or **Options** Button.
- 3) Select the **Sensors** Button.
- 4) Select the **AHRS** or **ADC** Button, then the desired AHRS or ADC source.



NOTE: Manual switching of AHRS or ADC sensors is not available if the GI 275 is interfaced to a GFC 500 Autopilot.

VFR GPS RECEIVER OPERATION

Internal system checking is performed to ensure the internal VFR GPS receiver is operating correctly.

Viewing VFR GPS receiver status:

From any page, open the menu and select **System > VFR GPS**.

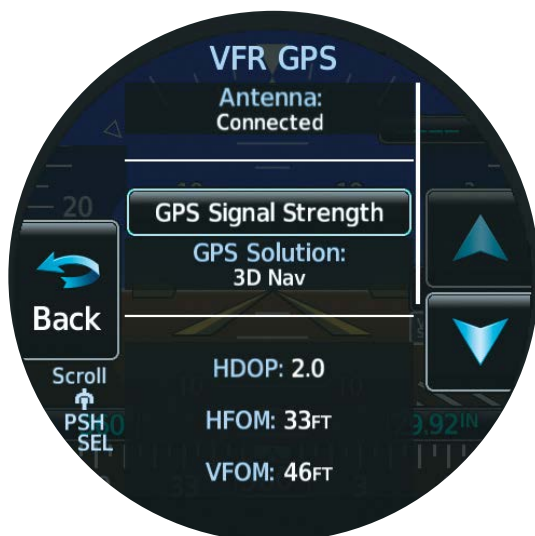

VFR GPS Receiver Status



NOTE: The United States government operates the Global Positioning System and is solely responsible for its accuracy and maintenance. The GPS system is subject to changes which could affect the accuracy and performance of all GPS equipment. Portions of the system utilize GPS as a precision electronic NAVigation AID (NAVAID). Therefore, as with all NAVAIDs, information presented by the system can be misused or misinterpreted and, therefore, become unsafe.

The GPS Solution will display one of the following conditions:

- Autolocate—Receiver is looking for any satellite whose almanac has been collected, which can take up to 5 minutes.
- Searching the Sky—Receiver is looking for satellites.

- Acquiring Satellites—Receiver is looking for and collecting data from satellites visible at its last known or initialized location but has not acquired a fix.
- 2D Nav—At least three satellites have been acquired and a two-dimensional location fix has been calculated.
- 2D Diff Nav—At least three satellites have been acquired and a two-dimensional location fix has been calculated, with SBAS corrections applied.
- 3D Nav—At least four satellites have been acquired and a three-dimensional fix has been calculated.
- 3D Diff Nav—At least four satellites have been acquired and a three-dimensional fix has been calculated, with SBAS corrections applied.
- Lost Satellite Reception—the receiver is no longer tracking enough satellites for a valid position fix.

Acquiring Satellites

When the receiver is in the process of acquiring enough satellite signals for navigation, the receiver uses satellite orbital data (collected continuously from the satellites) and last known position to determine the satellites that should be in view. “Acquiring Satellites” is indicated as the solution until a sufficient number of satellites have been acquired for computing a solution.

Satellite Information

Satellites currently in view are shown at their respective signal strengths accessed from the **GPS Signal Strength** Button. The 'GPS Signal' Screen can be helpful in troubleshooting weak (or missing) signal levels due to poor satellite coverage or installation problems. As the GPS receiver locks onto satellites, a signal strength bar is displayed for each satellite in view, with the appropriate satellite identification number adjacent to each bar. The progress of satellite acquisition is shown as indicated by signal bar appearance:

- No bar—Receiver is looking for a satellite
- Green bar—Receiver has found the indicated satellite

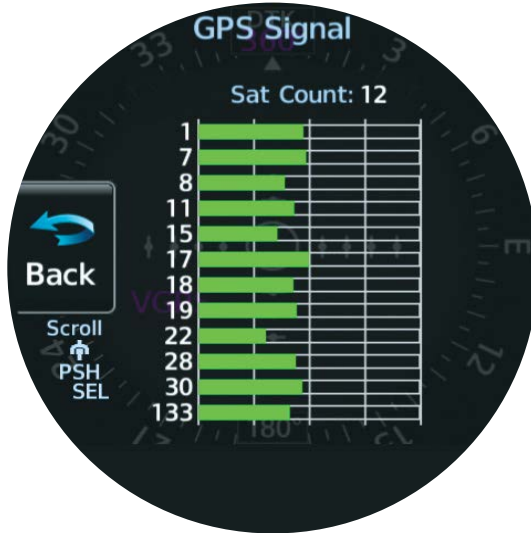

VFR GPS Satellite Signals

Current Position

The lower portion of the 'VFR GPS' Screen displays current latitude, longitude, time, GPS altitude, ground speed, and track.



VFR GPS Current Location

1.5 ACCESSING SYSTEM FUNCTIONALITY

SYSTEM SETTINGS

Crew Profiles

Crew profiles save various system settings and can be loaded quickly on start. The 'Crew Profile' Screen allows you to add, rename, activate, copy, or delete up to seven crew profiles. In addition, crew profiles can be imported from, or exported to, a USB drive. 'Default' is the standard active crew profile and cannot be deleted or renamed. When a Crew Profile is active (including 'Default'), all modified MFI settings are saved to that profile without any crew interaction.

Accessing Crew Profile options:

From any page, open the menu and select **System > Crew Profile**.

Creating a Crew Profile:

- 1) From the 'Crew Profile' Screen, select **New**.
- 2) Input a Crew Profile name (up to 8 characters).
- 3) Touch the **Enter** Button or push the Small Knob.
- 4) A "New crew profile will be created with the current system settings." message appears.
- 5) Select the **Create/Act** Button to create the profile.



NOTE: If the MFI is at the maximum crew profile limit, no crew profiles can be imported.



NOTE: If more than 50 crew profiles are available on the USB drive, only the first 50 profiles are listed for import.

Importing a Crew Profile using USB device:

- 1) Insert a USB drive into the USB dongle or optional GSB 15.
- 2) From any page, open the menu; select **System** and select **Crew Profile**.
- 3) Select the **Import** Button.
- 4) Select the name of the profile to import (cannot import a profile which has the same name as the currently active profile).
- 5) If a duplicate profile name exists, an "Importing this profile will overwrite profile (profile name) Confirm import?" message appears. Select the **OK** Button.
- 6) An "Import Successful!" message appears. Select the **OK** Button.

Switching Crew Profiles:

- 1) From the 'Crew Profile' Screen, select the desired inactive profile.
- 2) Select the **Activate** Button.

Renaming Crew Profiles:

- 1) From the 'Crew Profile' Screen, select the desired profile ('Default' and the active profile cannot be renamed).
- 2) Select the **Rename** Button.
- 3) Input the updated Crew Profile name.
- 4) Touch the **Enter** Button or push the Small Knob to accept changes.

Exporting Crew Profiles using a USB device:

- 1) Insert a USB drive into the USB dongle or optional GSB 15.
- 2) From any page, open the menu; select **System** and select **Crew Profile**.
- 3) Select the profile to export.
- 4) Select the **Export** Button.
- 5) If a duplicate profile name exists, an "Export profile (profile name)? Export will overwrite any profile on the storage device with this name." message appears. Select the **OK** Button.
- 6) An "Export Successful!" message appears. Select the **OK** Button.

Deleting Crew Profiles:

- 1) From the 'Crew Profile' Screen, select the desired profile ('Default' cannot be deleted).
- 2) Select the **Delete** Button.
- 3) Confirm deletion by selecting the **OK** Button.

Date/Time

The MFI will automatically set system time from GPS or connected compatible Garmin devices. By default, system time is displayed in UTC (also called Zulu Time). If there is no GPS time source, it is possible to manually set the date and time.

Accessing MFI system date and time settings:

From any page, open the menu and select **System > Setup > Date / Time**.

Changing MFI time display format:

- 1) From any page, open the menu and select **System > Setup > Date / Time > Time Options > Time Format**.
- 2) Select the desired setting (**12 Hour, 24 Hour, UTC**).

Changing MFI time display offset:

- 1) From any page, open the menu and select **System > Setup > Date / Time > Time Options > Time Format**.
- 2) Select either the **12 Hour** Button or the **24 Hour** Button.
- 3) Select the **Time Offset (Hr)** Data Field.
 - a) Use the Large Knob to highlight the **Time Offset (Hr)** Data Field.
 - b) Use the Small Knob to adjust the number of hours local time is offset from UTC.

Or:

 - a) Select the **Time Offset (Hr)** Data Field. A keypad is displayed.
 - b) Use the keypad or Small Knob to set number of hours local time is offset from UTC.
 - c) Touch the **Enter** Button or push the Small Knob to save changes.

Manually setting MFI system date:

From any page, open the menu and select **System > Setup > Date / Time > Set Date**.

- a) Use the Large Knob and highlight the **Year, Month, or Day** Data Field.
 - b) Use the Small Knob to adjust the data field value. Changes are saved automatically.
- Or:**
- a) Select the **Year, Month, or Day** Data Field. A keypad is displayed.
 - b) Use the keypad to enter the desired value for the data field. Touch the **Enter** Button or push the Small Knob to save changes.

Manually setting MFI system time:

From any page, open the menu and select **System > Setup > Date / Time > Set Time**.

- a) Use the Large Knob and highlight the **Hour or Minute** Data Field.
 - b) Use the Small Knob to adjust the data field value. Changes are saved automatically.
- Or:**
- a) Select the **Hour or Minute** Data Field. A keypad is displayed.
 - b) Use the keypad to enter the desired value for the data field. Touch the **Enter** Button or push the Small Knob to save changes.

Units of Measure

The MFI can display barometric pressure, altitude, distance, fuel, navigation angle, and temperature in a variety of units of measure.

Opening the Units Menu:

From any page, open the menu and select **System > Units**.

Adjusting barometric pressure units:

- 1) From the 'Units' Menu, select the **BARO Pressure** Data Field.
- 2) Select the desired units of measure (**inHg, hPa, or mb**).

Adjusting altitude units:

- 1) From the 'AUX Units' Menu, select the **Altitude** Data Field.
- 2) Select the desired units of measure (**Feet or Meters**).

Adjusting distance units:

- 1) From the 'Units' Menu, select the **Distance** Data Field.
- 2) Select the desired units of measure (**Nautical Miles or Kilometers**).

Adjusting fuel computer units:



NOTE: Fuel unit adjustments do not affect fuel quantity or fuel flow gauges. Contact a Garmin Dealer or installer for unit adjustment.

- 1) From the 'Units' Menu, select the **Fuel Computer** Data Field.
- 2) Select the desired units of measure (**Gallons, Liters, or Pounds**).

Adjusting navigation angle units:

- 1) From the 'Units' Menu, select the **Nav Angle** Data Field.
- 2) Select the desired units of measure (**Magnetic or True**).

Adjusting temperature units:



NOTE: Temperature unit adjustments do not affect temperature gauges. Contact a Garmin Dealer or installer for unit adjustment.

- 1) From the 'Units' Menu, select the **Temperature** Data Field.
- 2) Select the desired units of measure (**Celsius or Fahrenheit**).

Airport Runways

Setting airport criteria affects which airports are displayed on the Direct To 'Nearest' Menu. See the Navigation Section for details.

1.6 DISPLAY BACKLIGHTING

The MFI has a built-in photocell to detect ambient lighting conditions and adjusts its display brightness accordingly. In certain installations, the MFI is integrated with the aircraft lighting dimming bus and will respond to dimming bus changes. If automatic or dimming bus

brightness changes are inadequate, display brightness can be adjusted from the MFI directly.

Adjusting display brightness:

- 1) From any page, open the menu and select **Backlight**.
- 2) Use the arrow buttons or turn the Small Knob to adjust display brightness offset.
- 3) Select the **Back** Button to save settings.



GI 275 Built-In Photocell

1.7 DEVICE REGISTRATION

Unregistered MFIs cannot install critical databases or updates. To register the MFI, create a Garmin account at flygarmin.com and add the MFI as a device on the account. Before registering the MFI, obtain the System ID of the MFI.

Obtaining MFI System ID:

- 1) From any page, open the menu and select **System > Info**.
- 2) Note the System ID number as shown in the following example. The System ID is required when registering the device.



GI 275 System ID

1.8 WIRELESS CONNECTIVITY (GARMIN CONNEXT)

The MFI has built-in Wi-Fi and Bluetooth capabilities. Connex allows for a wireless connection between the MFI and a Personal Electronic Device (PED) running the Garmin Pilot application and provides up-to-date information throughout the cockpit.

The following features are available on a PED through Garmin Pilot:

- GPS position, velocity, and time information
- Uncorrected barometric pressure altitude used by transponder and ADS-B
- ADS-B In traffic data
- FIS-B weather and flight information
- AHRS data from built-in sensor
- Magnetic heading
- Flight Plan Transfer (see the Navigation Section for details on transferring flight plans).

BLUETOOTH SETUP

The mobile device must be 'paired' with the system in order to use the various functions. Pairing is accomplished once for each device. After the initial pairing, with 'Auto-Reconnect' enabled, your PED will automatically reconnect with the MFI. The pairing operation is completed from the mobile device and the Garmin Pilot application. For additional references, see the device Bluetooth pairing instructions and the connection instructions in the Garmin Pilot application.



NOTE: The MFI allows pairing of up to thirteen (13) Bluetooth devices, with four simultaneous device connections.

Pairing a PED using Bluetooth:

- 1) From any page, open the menu and select **System > Wireless**. The MFI may take up to two minutes for wireless capability to initialize. When wireless capability is ready, the **System > Wireless** Button will be enabled.
- 2) Select the **Pair a Device** Button. The following screen is displayed while you connect your PED using Bluetooth. See your PED's instruction manual for details on how to connect your device using Bluetooth.



Pair Device

- 3) In the preceding example, the MFI's Bluetooth name is 'GI 275-6901.' Connect to this device on your PED.

- 4) The MFI will display the following image to indicate a PED is attempting to establish a Bluetooth connection.



Received Pairing Request

- 5) Touch the **Pair** Button to complete the procedure; use the pairing code as required.

MANAGING PAIRED DEVICES

With a PED connected to the MFI, you can view all devices that are connected as well as those connections that have been established but are not currently connected. You can enable and disable automatic reconnection of a PED, and you can remove a paired device.

Viewing connected devices

- 1) From any page, open the menu and select **System > Wireless**.
- 2) Scroll down and select the **Bluetooth Devices** Button.



Accessing Bluetooth Devices

- 3) A list of devices is displayed on the next screen. Select your connected device.
- 4) In the following example, the PED's name is 'IPad Mini 4' and its status is 'online.' Use this information to confirm your PED is connected and online.



Bluetooth Device

Enabling/disabling automatic reconnection of a paired device:

- 1) From any page, open the menu and select **System > Wireless > Bluetooth Devices**.
- 2) A list of devices is displayed on the next screen. Select your connected PED.
- 3) Note in the preceding image, the device by default is configured to automatically reconnect (green annunciator is illuminated).
- 4) Select the **Auto-Reconnect** Button to disable the automatic reconnection functionality (green annunciator is not illuminated).

Removing a paired device:

- 1) From any page, open the menu and select **System > Wireless > Bluetooth Devices**.
- 2) A list of devices is displayed on the next screen. Select your connected PED.
- 3) Select the **Remove Device** Button to remove the selected PED from the MFI.

1.9 DATABASES



NOTE: *Databases cannot be updated while in flight.*

Non-EIS MFIs rely on various databases to provide navigation, mapping, and alerting functions. If any databases are out of date, the related functions may be degraded or cease operation entirely. Databases are stored in the unit's internal memory. To view update cycles, or to purchase individual database packages, go to flygarmin.com. Databases may be updated from a USB drive, another Garmin LRU, or wirelessly through Garmin Pilot (Database Concierge).

Supported Databases

| | |
|-------------------|--|
| Basemap | Bodies of water, geopolitical boundary, and road information |
| Obstacle | Obstacle and wire data |
| Terrain | Terrain elevation data |
| Navigation | Airport, NAVAID, waypoint, and airspace information |
| SafeTaxi | Airport surface diagrams |

Cross-checking database validity:

- 1) From any page, open the menu and select **System > Databases > Show Active DBs**.
- 2) Compare database expiration dates to the current date and check no databases are expired. The MFI compares expiration dates to system time, indicates expired databases in yellow, and issues a system advisory alerting the crew to the condition.
- 3) Sync Status across GI 275 is also displayed, pressing any of the Database Buttons will display which GI 275s are in sync with the current GI 275.



'Active Databases' Screen

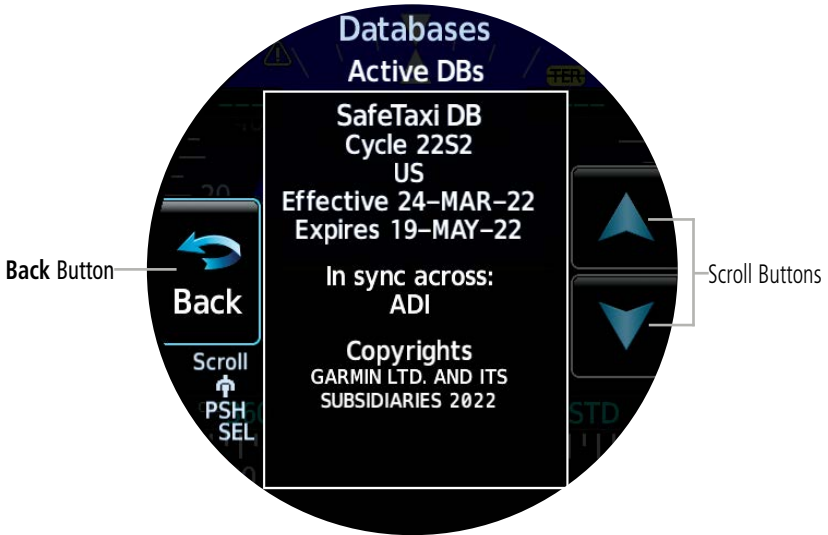

Safe Taxi - Full Info

AUTOMATIC DATABASE UPDATES

Automatic updates occur when a newer database is detected in the internal standby queue, a newer database is on a connected compatible Garmin LRU, a newer database is within its effective dates, and the aircraft is on the ground.

When a newer database is available, the update process will start in the background without requiring user action. To view the status of an in-progress sync from any page, open the menu and select **System > Databases > Show Sync Progress**. Databases will be added to the list as they begin to sync across compatible Garmin LRUs. Some databases may take longer than others to transfer.



NOTE: *The GI 275 can receive database updates from another compatible Garmin LRU, but will only provide database updates to a GI 275, GPS 175, GNC 355, or GNX 375.*

Database sync using a connected Garmin LRU (optional):

- 1) Load updated databases into the connected compatible Garmin LRU (e.g., a GTN or another MFI). See the pertinent flight manual for the specific LRUs for more details.
- 2) Databases will synchronize in the background automatically.
- 3) When the database sync is completed and the aircraft is on the ground, the new databases will be activated automatically.

DATABASE SYNC OPTIONS

Automatic Database Sync Options can be found by selecting **System > Databases > DB Sync Options**. The user then has three control options in this menu item.

Adjusting database sync options:

- 1) Select **Disabled**, which will disable automatic database sync.
- 2) Select **Enabled**, which will enable automatic database sync.
- 3) Select **GI275 Only**, which enables automatic database sync only if the source is another GI 275.

MANUALLY UPDATING DATABASES

Updating databases using a USB device:

- 1) Prepare a USB storage device with updated databases.
- 2) Insert the prepared USB storage device into the USB dongle or optional GSB 15.
- 3) After inserting the USB, a pop-up will appear prompting a Database Update.

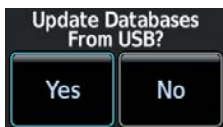

NOTE: It is recommended to use a USB thumbdrive no larger than 32 GB. The USB may not be detected for up to one minute after the GI 275 is powered On. If the USB is inserted after one minute, detection of the USB and it's databases may take up to 15 seconds.

- 4) If No is selected on the pop-up, the update can be started from any page by opening the menu and selecting **System > Databases > Update > Update Using USB**.

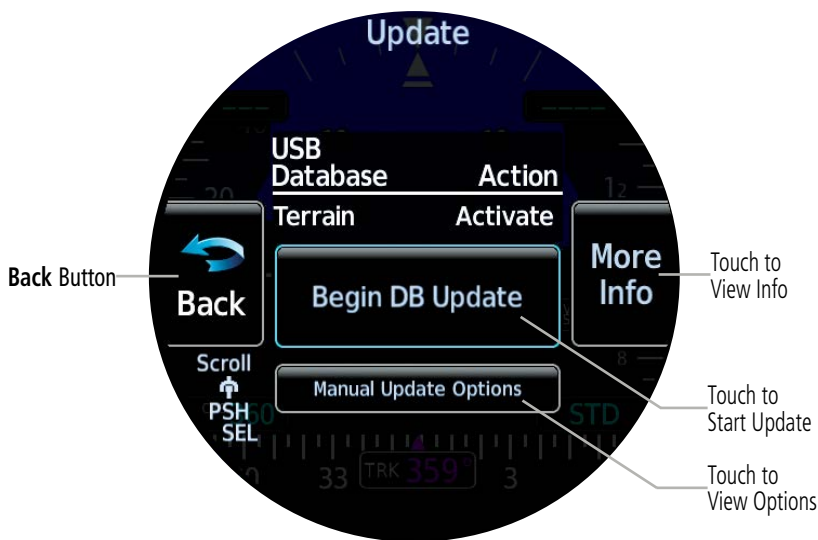

USB Update - List

- 5) Select the **Begin DB Update** Button to start an update of any databases listed in the table.
- 6) Select the **More Info** Button to display more information about what databases are on the USB and GI 275.

- 7) Select the **Manual Update Options** Button, which allows selection of one or more updates from the USB.
- 8) If **Manual Update Options** is pressed: Select the database(s) to update. Select the **Update Selected** Button.
Or:
Select the **Update All** Button.
- 9) Wait for databases to update. A progress bar is shown for each selected update.
- 10) If there are other Garmin units in the system that need to receive the new databases, the status of the sync to those units will be displayed as well.
- 11) When all database updates and syncs are complete, all GI 275s will begin using the new databases without requiring a restart. A list of the completed updates will be displayed.

Database Concierge

Database Concierge allows wireless transfer of databases from a mobile device while the aircraft is on ground. A pilot selects and downloads databases inside the Garmin Pilot application. Transfers occur once a wireless connection is established inside the aircraft.

Database Concierge provides the following features:

- Automatic updates for databases with effective dates
- An internal standby queue for pre-loaded databases that are not yet effective
- Displays database type, cycle, effective date, and transfer progress

Wi-Fi SETUP

To enable Database Concierge functionality, a Wi-Fi connection must be established between the PED and MFI.



NOTE: *SSID and Password Fields are limited to eight (8) characters and it is recommended to use letters in mixed case, along with numbers, for increased security.*

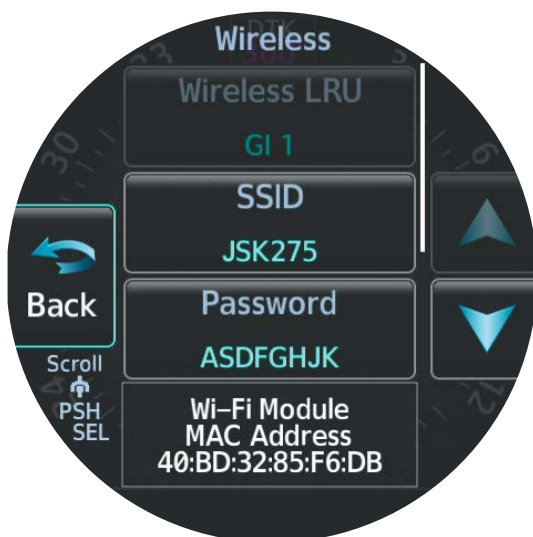

Wi-Fi Setup

Setting the Wi-Fi name (SSID) and password:

- 1) From any page, open the menu and select **System > Wireless**.
- 2) Select the **SSID** Data Field.
- 3) Input the desired Wi-Fi SSID name for the PED to connect to.
- 4) Select the **Password** Data Field.
- 5) Input the desired Wi-Fi password for the PED to use when connecting to the MFI.

Updating databases through Garmin Pilot (Database Concierge):

- 1) Prepare a mobile device with the Garmin Pilot mobile application and updated databases. See the Garmin Pilot for iOS or Garmin Pilot for Android user manual for details.
- 2) From any page, open the menu and select the **System** Button. Then, select the **Databases** Button.
- 3) Select the **Update** Button.
- 4) Select the **Update Using Connex (Wi-Fi)** Button.
- 5) Connect the desired mobile device to the MFI using the provided SSID and password, then open **Garmin Pilot**.
- 6) Either proceed with the default **Begin DB Update** Button.

Or:

Manually select the databases to update with the **Manual Update Options** Button. Touch the **Update** Button.

- 7) Wait for databases to update. A progress bar is shown for each selected update.
- 8) If there are other Garmin units in the system that need to receive the new databases, the status of the sync to those units will be displayed as well.
- 9) When all database updates and syncs are complete, all GI 275s will begin using the new databases without requiring a restart. A list of the completed updates will be displayed.

Enabling/disabling Wi-Fi database importing from Garmin Pilot:

- 1) From any page, open the menu and select **System > Wireless > Connex Features**.
- 2) Select the **Database Update** Button to enable/disable Wi-Fi Database Import from Garmin Pilot.

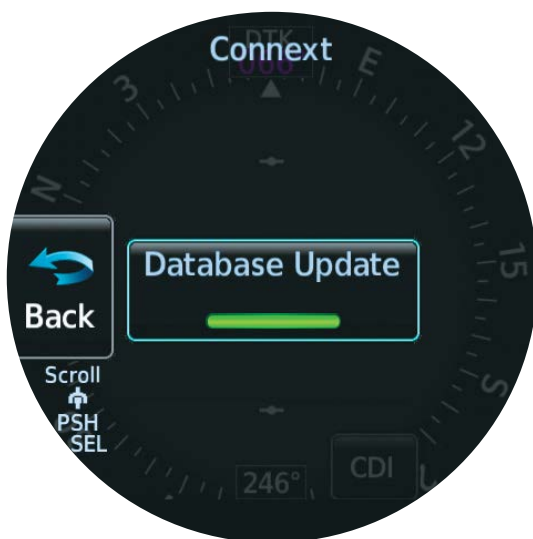

'Connex' Screen

SECTION 2 FLIGHT INSTRUMENTS

2.1 FLIGHT INSTRUMENTS

This section covers instrumentation on the 'ADI', 'CDI', 'HSI', and 'HSI Map' Pages.



NOTE: When configured as a Primary ADI or Primary HSI, a half screen menu is available and individual page options are accessed via the generic **Options** button. When configured as a Standby ADI or MFD, a full screen menu is available and individual page options are accessed via the page-specific Options button (e.g. **ADI Options Button** on the 'ADI' Page Menu).

ATTITUDE INDICATOR

Attitude information is displayed over a virtual blue sky and brown ground with a white horizon line. The Attitude Indicator displays the pitch (indicated by the symbolic aircraft on the pitch scale), roll, and slip/skid information.

The horizon line is part of the pitch scale. Pitch markings occur at 2.5° intervals between ±20° and at 5° intervals through all other pitch ranges.

Two roll pointer styles exist: sky and fixed. The inverted white triangle indicates zero on the roll scale. Major tick marks at 30° and 60° (with air data information, on fixed pointer only), minor tick marks at 10° and 20°, and inverted hollow triangles at 45° are shown to the left and right of the zero. Angle of bank is indicated by the position of the pointer on the roll scale.

Slip/skid is indicated by the location of the trapezoid under the roll scale pointer.



Attitude Indicator

- System Overview
- Flight Instruments
- EIS
- Navigation
- Hazard Avoidance
- Autopilot
- WSI
- Additional Features
- Appendices
- Index



Attitude Indicator - Rotorcraft

Standard Rate Turn Bank Angle Pointers (with compatible OAT sensor connected)

The Standard Rate Turn Bank Angle Pointers are "airplane" pointers displayed on the roll scale that show the bank angle needed for a standard rate turn at the known true airspeed.

Standard Rate Turn Bank Angle Pointers



AIRSPEED INDICATOR



NOTE: The Vspeed Reference values depend upon the aircraft's specific system configuration and may vary from the examples portrayed in this document.

The Airspeed Indicator displays airspeed on a rolling number gauge using a moving tape. The numeric labels and major tick marks on the moving tape are marked at intervals of 10 knots and minor ticks every 5 knots. Speed indication starts at 20 knots. The indicated airspeed is displayed inside the black pointer. The pointer remains black until reaching the configured never-exceed speed (VNE), at which point it turns red.

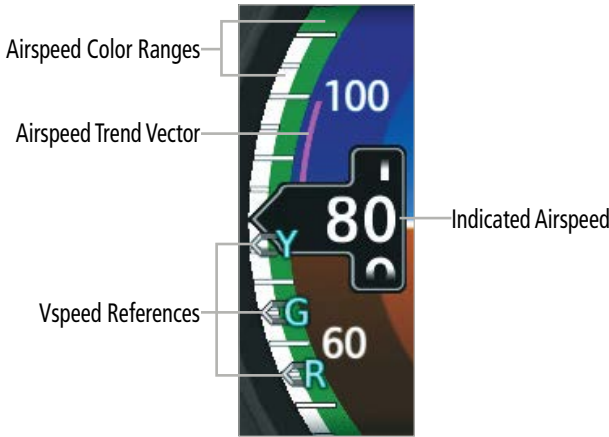

Airspeed Indicator

A color-coded (red, white, green, and yellow) speed range strip is located on the moving tape. The colors denote flaps operating range, normal operating range, caution range, and never-exceed speed (V_{NE}). A red range is present for low speed awareness. For multi-engine aircraft, a red radial line for V_{MCA} and blue radial line for V_{YSE} is also displayed.

The Airspeed Trend Vector is a vertical magenta line, extending up or down on the airspeed scale, shown to the right of the color-coded speed range strip. The end of the trend vector corresponds to the predicted airspeed in 6 or 10 seconds, depending on the configuration, if the current rate of acceleration is maintained.

If the trend vector crosses V_{NE}, the text color of the indicated airspeed changes to yellow. The trend vector is absent if the speed remains constant or if any data needed to calculate airspeed is not available due to a system failure. Exceeding V_{NE} results in the indicated airspeed becoming white with a red background.

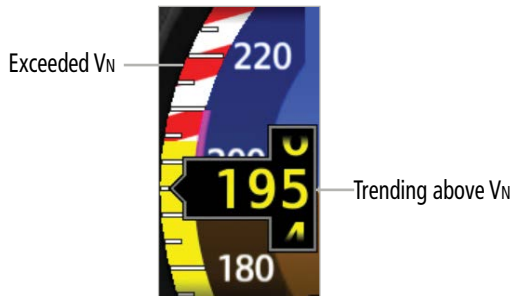

Airspeed Indicator - Approaching and Exceeding V_{NE}



NOTE: Depending on installation and configuration, exceeding or going below certain airspeeds may result in various actions including warnings and/or autopilot disconnects. Consult your installer for details.

Vspeed References

Depending on configuration, various Vspeed references ("bugs") including Glide, V_x , V_y , V_{LE} , and V_R are available.

Enabled Vspeeds display at their respective locations on the airspeed indicator tape.

Toggle Vspeed visibility (except V_{LE} , V_{MCA} , and V_{YSE}):

- 1) From the 'ADI' Page, open the menu and select **Options > Airspeeds**.
- 2) Select the **All On, All Off**, or specific Vspeed Buttons desired.

Adjusting Vspeed values (except V_{LE} , V_{MCA} , and V_{YSE}) on a Primary ADI:

- 1) From the 'ADI' Page, open the menu and select **Options > Airspeeds**.
- 2) Use the Large Knob to highlight the Vspeed requiring adjustment.
- 3) Use the Small Knob to adjust the Vspeed, clockwise to increase and counterclockwise to decrease. Changes are saved automatically and restore to defaults on unit restart.

Adjusting Vspeed values (except V_{LE} , V_{MCA} , and V_{YSE}) on a Standby ADI:

- 1) From the 'ADI' Page, open the menu and select **ADI Options > Airspeeds**.
- 2) Select the Vspeed requiring adjustment.
- 3) Use the Knobs or keypad to adjust the Vspeed. Changes are saved automatically and restore to defaults on unit restart.

Restoring Vspeed default values:

- 1) From the 'ADI' Page, open the menu and select **Options > Airspeeds**.
- 2) Select the **Restore Defaults** Button. All crew-adjusted Vspeed values will restore to configured defaults.

ALTIMETER

The Altimeter displays barometric altitude on a rolling number gauge using a moving tape. Numeric labels and major tick marks are shown at intervals of 100 feet. Minor tick marks are at intervals of 50 feet. The indicated altitude is displayed in the black pointer.

The Selected Altitude (if enabled) is displayed above the Altimeter. A bug corresponding to this altitude is shown on the tape; if the Selected Altitude exceeds the range shown on the tape, the bug appears at the corresponding edge of the tape.

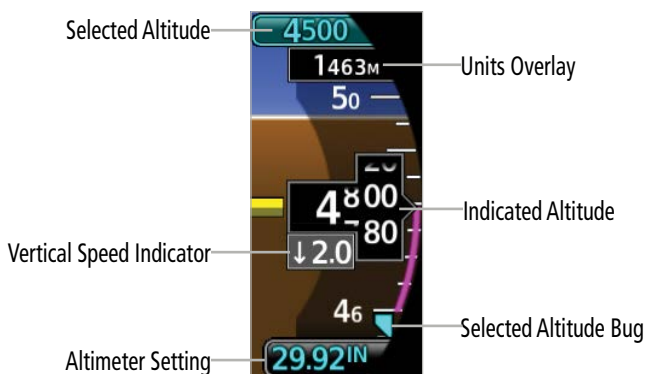

Altimeter and Selected Altitude

Changing the selected altitude:

- 1) From the 'ADI' Page, touch the Selected Altitude field.
- 2) Turn the Small Knob clockwise to increase or counterclockwise to decrease the Selected Altitude bug in 100-foot increments.

Syncing the selected altitude to the current altitude:

Touch and hold the Selected Altitude field.

Or:

Touch the Selected Altitude field and push the Small Knob.

Altimeter Barometric Pressure Setting



WARNING: Do not use a QFE altimeter setting with this system. System functions will not operate properly with a QFE altimeter setting. Use only a QNH altimeter setting for height above mean sea level, or the standard pressure setting, as applicable.

The barometric pressure setting is displayed below the Altimeter in inches of mercury (in Hg), hectopascals (hPa), or millibars (mb).

Changing the altimeter barometric pressure setting:

- 1) Touch the Barometric Pressure Datafield.
- 2) Turn the Small Knob clockwise to increase or counterclockwise to decrease the altimeter setting.

toggling the altimeter barometric pressure setting to/from STD BARO (29.92 in Hg / 1013 hPa):

Touch the Barometric Pressure Datafield. Push the Small Knob.

Or:

Touch and hold the Barometric Pressure Datafield.

Ground Line

When equipped and configured with a compatible radar/radio altimeter, the altimeter displays a ground line. In the following example, the aircraft is 100 feet above the ground:

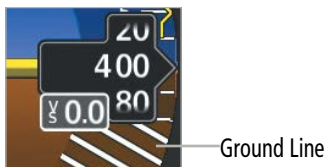

Altimeter - Ground Line

Units Overlay

A secondary altitude overlay field can be enabled to display the current altitude converted to either:

- feet (when current altitude tape displays meters)
- meters (when current altitude tape displays feet)

This field is enabled by selecting:

ADI Options > Overlay > feet/meters.

ALTIMETER (GSL BACKUP)



WARNING: Do not use geometric altitude for compliance with air traffic control altitude requirements. The primary barometric altimeter must be used for compliance with all air traffic control altitude regulations, requirements, instructions, and clearances.

In the event of all static air data sources failing but GPS data is available, the 'ADI' Page can display Geometric Sea Level (GSL) altitude as a backup altitude source. GSL altitude is derived from GPS altitude. GSL altitude accuracy is affected by satellite geometry but is not subject to variations in pressure and temperature that normally affect pressure altitude sensors; GSL altitude does not require local altimeter settings to determine MSL altitude, thus the altimeter setting field is disabled when using GSL altitude.

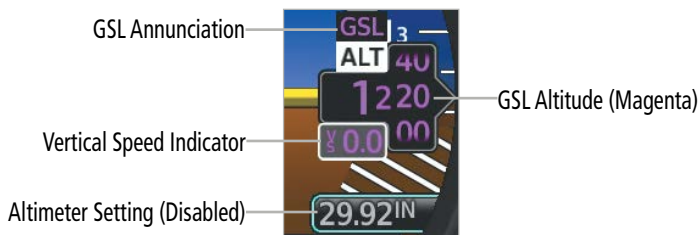

Altimeter - GSL

VERTICAL SPEED INDICATOR (VSI)



NOTE: Changing Vertical Speed (VS) range configuration changes ALT / IAS tape ranges.

The Vertical Speed Indicator displays the aircraft vertical speed below the altimeter. The indications are in thousands of feet per minute or in meters per second as configured by the installer.

Vertical Speed range can be configured as follows:

| +/- 2000 FPM | +/- 3000 FPM | +/- 4000 FPM |
|-------------------|-------------------|-------------------|
| ALT Range: 500 ft | ALT Range: 600 ft | ALT Range: 700 ft |
| IAS Range: 60 kts | IAS Range: 70 kts | IAS Range: 80 kts |

A magenta Altitude Trend Vector extends up or down the right of the altitude tape, the end resting at the approximate altitude to be reached in 6 seconds at the current vertical speed. The trend vector is not shown if altitude remains constant or if data needed for calculation is not available due to a system failure.



Vertical Speed Indicator and Altitude Trend Vector

HEADING INDICATOR



WARNING: Do not rely on the accuracy of heading indications in the following geographic areas (due to variations in the earth's magnetic field): North of 72° North latitude at all longitudes; South of 70° South latitude at all longitudes; North of 65° North latitude between longitude 75° W and 120° W. (Northern Canada); North of 70° North latitude between longitude 70° W and 128° W. (Northern Canada); North of 70° North latitude between longitude 85° E and 114° E. (Northern Russia); South of 55° South latitude between longitude 120° E and 165° E. (Region south of Australia and New Zealand).

The current heading is displayed on a rotating compass card in a heading-up orientation on the 'ADI' (if configured), 'HSI', and 'HSI Map' Pages. If heading data is unavailable, the track derived from GPS data is displayed instead. Letters indicate the cardinal points and numeric labels occur every 30°. Major tick marks are at 10° intervals and minor tick marks at 5° intervals.

Adjusting the selected heading:

- 1) From the 'HSI' or 'HSI Map' Page, touch the **HDG** Button if it is not already highlighted.
Or:
From the 'ADI' Page, touch the Heading Datafield below the airspeed indicator.

- 2) Turn the Small Knob.

Synchronizing the selected heading to the current heading:

Touch and hold the Heading Datafield or **HDG** Button.

Or:

- 1) From the 'HSI' or 'HSI Map' Page, touch the **HDG** Button if it is not already selected.
Or:
From the 'ADI' Page, touch the Heading Datafield below the airspeed indicator.
- 2) Push the Small Knob.



'ADI' Page



'HSI' Page



'HSI Map' Page

Heading Indicator Types - 'ADI', 'HSI', and 'HSI Map' Pages

Should the magnetometer fail, and GPS data is valid, ground track data is displayed instead of heading. Track data is annunciated as "TRK" and the indications are in magenta.



'ADI' Page



'HSI' Page



'HSI Map' Page

Ground Track Data - 'ADI', 'HSI', and 'HSI Map' Pages

DEVIATION INDICATORS



NOTE: An external navigator (e.g., NAV/COM Transceiver and/or the GTN or GNS Series Units) must be configured to receive glideslope and/or glidepath vertical deviation indications.

Up to two external sources for GPS and VOR/LOC data may be configured as navigation sources (GPS1, GPS2, VOR/LOC1, VOR/LOC2). If an external GPS source is not configured or all external GPS sources have failed, the deviation indicators can display VFR GPS data (VGPS). See the Navigation section for details. Color indicates the current navigation source:

magenta (for GPS) or green (for VOR and LOC). The full-scale limits for the CDI are defined by a GPS-derived distance when coupled to GPS. When the MFI is receiving VOR/LOC or GPS data (GPS must be in OBS Mode), adjustments to the course may be made on the 'CDI' Page, 'HSI' Page, or 'HSI Map' Page. The course may also be adjusted using the external navigator, if configured. Refer to the current pertinent flight manual for the external navigator in use for more information.

When coupled to a VOR or localizer (LOC), the deviation bar has the same angular limits as a mechanical CDI. If the deviation bar exceeds the maximum deviation on the scale while coupled to GPS, the crosstrack error (XTK) is displayed.

When valid navigation data is available, the 'CDI', 'HSI', and 'HSI Map' Pages always show deviation information. On the 'ADI' Page, lateral and vertical deviation indicators are not enabled by default. If deviation indicators on the 'ADI' Page are enabled before unit power-off, deviations will be displayed after unit restart. Units configured as a Standby HSI cannot disable deviation indication display on the 'ADI' Page.

Enabling/disabling deviation display on the 'ADI' Page:

- 1) From the 'ADI' Page, open the menu and select **Options > NAV Options**.
- 2) Select the **CRS Devs** Button to toggle displaying lateral and vertical deviation information.

Lateral Deviation

'ADI' AND 'HSI MAP' PAGES

The Lateral Deviation Scale and combination Course Deviation, To/From Indicator are located in the lower portion of the 'ADI' and 'HSI Map' Pages. An arrow pointing up is "To", while an arrow pointing down is "From". The center of the arrow can be considered the center of a traditional deviation bar.



'ADI' and 'HSI Map' Page - Lateral Deviation Indicator

Reverse Sensing on the 'ADI, HSI, and HSI Map' Page

The lateral deviation indicator incorporates an automatic reverse sensing correction. When the aircraft heading is more than 107° left or right from the selected course, the lateral deviation indicator will reverse CDI indications and the to/from pointer.

'HSI' PAGE

The 'HSI' Page Deviation Indicator contains a Course Pointer, To/From Indicator, and a sliding deviation bar and scale. The To/From flag is displayed when the active NAVAID is received.

'CDI' PAGE

- System Overview
- Flight Instruments
- ES
- Navigation
- Hazard Avoidance
- Autopilot
- IVI
- Additional Features
- Appendices
- Index

'CDI' Page deviation information is presented analogous to a traditional mechanical CDI.



Typical 'CDI' Page - External GPS Navigator

Vertical Deviation

'ADI', 'HSI', AND 'HSI MAP' PAGES

On the 'ADI', 'HSI', and 'HSI Map' Pages, vertical deviation data is presented on the right side of the MFL. Vertical deviation data is displayed when deviation display is enabled and the appropriate deviation source is selected with an external navigator providing valid vertical deviation data.

Glideslope - ILS Source

Whenever an ILS frequency is tuned in the active NAV field of an external navigator a green diamond acts as the VDI Indicator like a glideslope pointer on a conventional indicator. The green 'G' indicates an external glideslope source. If a localizer frequency is tuned and there is no glideslope signal, "NO GS" is annunciated in the vertical deviation indicator.

Glidepath - GPS Source

While an external navigator is on a GPS approach, the Glidepath Indicator appears as a magenta diamond. The magenta 'G' indicates a GPS source. If the approach type downgrades past the final approach fix (FAF), "NO GP" is annunciated.

VNAV Indicator

When a VNAV (vertical navigation) profile is defined by a compatible external navigator, a magenta chevron (VNAV Indicator) shows the VNAV profile on the VDI. The magenta 'V' indicates an external VNAV profile is active.

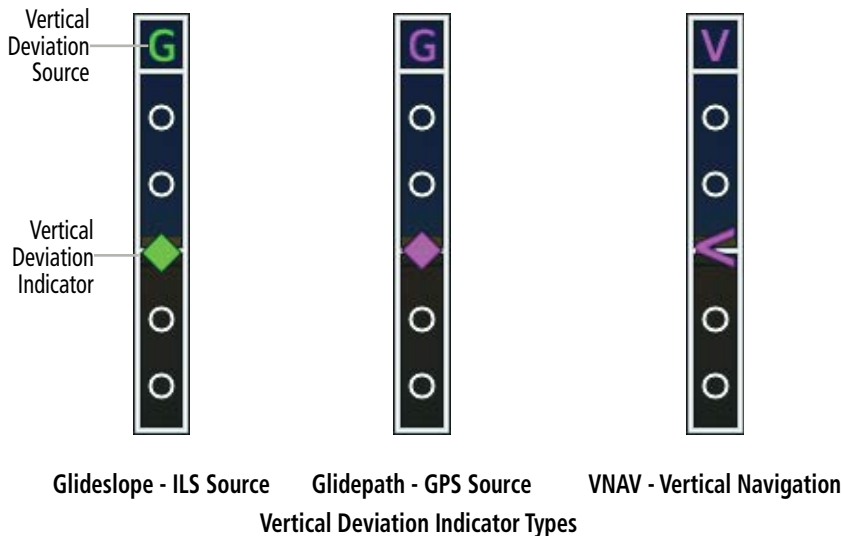

'CDI' PAGE

'CDI' Page deviation information is presented analogous to a traditional mechanical CDI.



'CDI' Page - ILS Approach Vertical Guidance

'HSI' and 'HSI Map' Page Course Pointer

The course pointer is a single line arrow (GPS1, VOR/LOC1) or a double line arrow (GPS2, VOR/LOC2) which points in the direction of the set course.

| Icon | Source | Icon | Source |
|------|----------|------|----------|
| | VOR/LOC1 | | VOR/LOC2 |
| | GPS1 | | GPS2 |

The deviation bar moves left or right from the course pointer along a lateral deviation scale to display aircraft position relative to the course. If the course deviation data is not valid, the deviation bar is not displayed.

Navigation Source Selection (GPS, VOR, LOC, or VLOC)

Use the associated external navigator to select the navigation source and tune VOR/LOC frequencies. Refer to the appropriate external navigator Pilot's Guide (e.g., SL30 Nav/Comm Transceiver Pilot's Guide, or the GTN or GNS Series Pilot's Guides, etc.) for more information.

Changing the navigation source:

From the 'CDI', 'HSI', or 'HSI Map' Page, touch the CDI Button to cycle through each CDI source.

Or:

- 1) From any page, open the menu and select **System > CDI Source**.
- 2) Select the desired CDI source.



NOTE: The internal GPS is only for VFR use.



NOTE: The course can be changed from a properly configured GTN when a GI 275 is running software version 3.0 or later.

Selecting the NAV radio radial:

- 1) From the 'CDI' Page, touch the OBS Datafield.

Or:

From the 'HSI' or 'HSI Map' Page, touch the CRS Datafield.

- 2) Turn the Small Knob to modify the selected radial.

Centering the NAV radio radial:

From the 'CDI' Page, touch and hold the OBS Datafield or touch the OBS Datafield and push the Small Knob.

Or:

From the 'HSI' or 'HSI Map' Page, touch and hold the CRS Datafield or touch the CRS Datafield and push the Small Knob.

CDI Scale

The CDI Scale will correspond to the current flight phase mode. The following modes are available using the internal VGPS:

OCN: the scale for Oceanic Mode is 4.0 nm.

ENR: the scale for Enroute Mode is 2.0 nm.

TERM: the scale for Terminal Mode is 1.0 nm.

If the MFI is configured to receive navigation guidance from another onboard compatible source, the CDI scale is determined by the external source and may support other flight phase modes such as approach and missed approach. See the pertinent flight manual for the external source for more information.

Lateral and Vertical Guidance Preview

The MFI can preview the lateral and vertical guidance pointers on the correct final approach course when an ILS, LOC, BC, LDA, or SDF approach is active in the external navigator and the navigator is using GPS until intercepting the final approach NAVAID.

Enabling CDI/VDI Preview:



NOTE: Only valid when interfaced with GTN series navigator.

- 1) From the 'HSI' or 'HSI Map' Page, open the menu and select '**(Page Name) Options**'.
- 2) Enable the **CDI/VDI Preview** Button.
- 3) With the appropriate approach activated and NAVAID tuned in the external navigator, verify the appropriate CDI Source is selected on the MFI (e.g., GPS1 or GPS2).
- 4) When the NAVAID is detected, the CDI/VDI Preview(s) appear on the 'HSI' or 'HSI Map' Pages.

Guidance Source Auto-Switching and Prompting

When interfaced with a compatible and appropriately configured Garmin GPS Navigator with a compatible Garmin NAV receiver, the MFI's displayed deviation source automatically changes based on certain conditions. If the MAP has been activated from the navigator, the guidance source switches to GPS. If on an ILS/LOC approach and the correct frequency is tuned, GPS is selected as the current guidance source, and the AFCS is roll-coupled to a localizer, the guidance source automatically switches to ILS/LOC before the FAF. Auto-switching only occurs with a GFC 600 autopilot and a GTN series navigator that is interfaced with the MFI. When on an ILS/LOC approach but GPS is selected as the guidance source, the **CDI** Button flashes to prompt the crew to switch guidance sources.

Enabling LOC CDI prompting:

From the 'CDI', 'HSI', or 'HSI Map' Page, open the menu and select '(Page Name) Options' > LOC CDI Prompting.

Current Track

The current track is represented on the 'HSI' and 'HSI Map' Pages by a magenta diamond on the compass rose.

Track - Magenta Diamond



OBS MODE



NOTE: If configured with an external navigator, OBS Mode can only be enabled by the selected external GPS navigator.

Enabling Omni-bearing Selector (OBS) Mode suspends the automatic sequencing of waypoints in a GPS flight plan but retains the current "active-to" waypoint as the navigation reference even after passing the waypoint. 'OBS' is annunciated when OBS Mode is selected.

While OBS Mode is enabled, a course line is drawn through the "active-to" waypoint on the moving map. If desired, the course to/from the waypoint can now be adjusted. When OBS Mode is disabled, the GPS flight plan returns to normal operation with automatic sequencing of waypoints. The flight path on the moving map retains the modified course line.

OBS Mode on 'HSI' Page

OBS Mode on 'CDI' Page

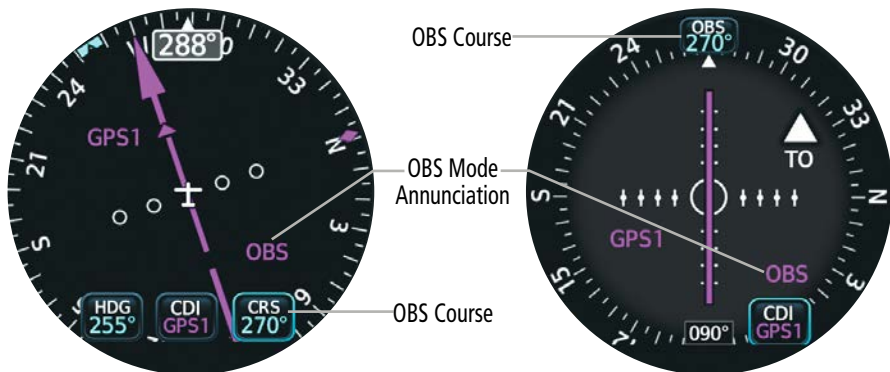

OBS Mode

Setting the course in OBS Mode (with external GPS navigator configured):

- 1) Activate OBS Mode using the external GPS navigator.
- 2) Use the external navigator to set the OBS course.

Or:

From the 'HSI' or 'HSI Map' Page, touch the **CRS** Button. Use the Knob to select the OBS course.

Or:

From the 'CDI' Page, touch the **OBS** Button. Use the Knob to select the OBS course.

Or:

From the 'CDI', 'HSI', or 'HSI Map' Page, open the menu and select '**(Page Name) Options' > CRS Options.**

SUSP Mode

If automatic waypoint sequencing is suspended, "SUSP" will be annunciated on any Page displaying course deviations ('ADI', 'CDI', 'HSI', and 'HSI Map'). For information on SUSP Mode using an external navigator, see the current pertinent flight manual for that navigator.

SYNC CONTROL

When properly configured, the GI 275 allows the user to enable and disable synchronization of BARO settings and the selected CDI source. There are two different synchronizations that can be changed, the Standby SYNC, and Side SYNC.

Standby SYNC Control

When properly configured, Standby SYNC is only available on units which are configured as a Standby unit. When disabled, the standby will isolate the selected setting from the rest of the system. This gives the unit its own independent selected CDI source or BARO setting.

Enabling Standby SYNC Control:

- 1) Press and Hold the Small Knob or Swipe Up on the screen to select **Menu > System > Setup**.

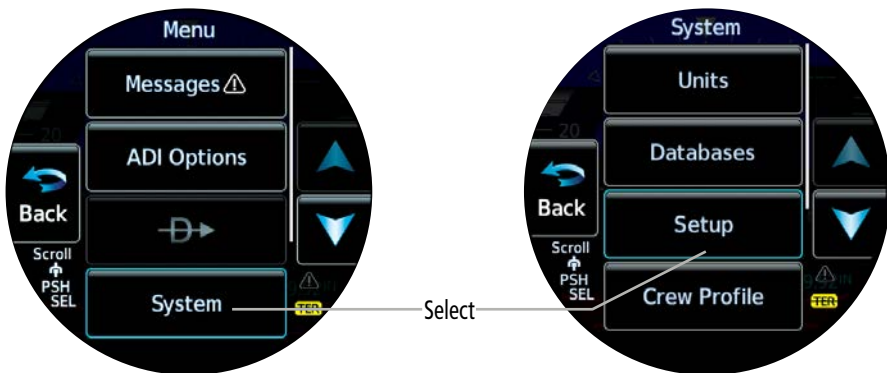

Standby SYNC Control - Main Menu & System Menu

- 2) From the Setup menu, select **SYNC Control > Standby SYNC**.

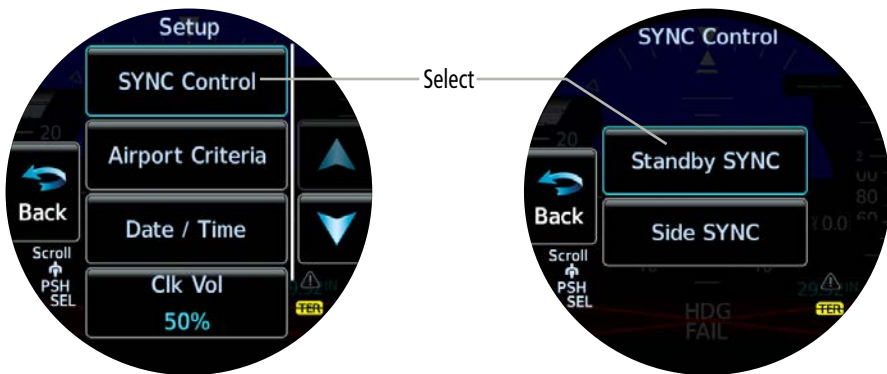

Standby SYNC Control - Setup Menu & SYNC Control Menu

- 3) From the Standby SYNC menu, select **BARO** and/or **CDI Source**, as desired.

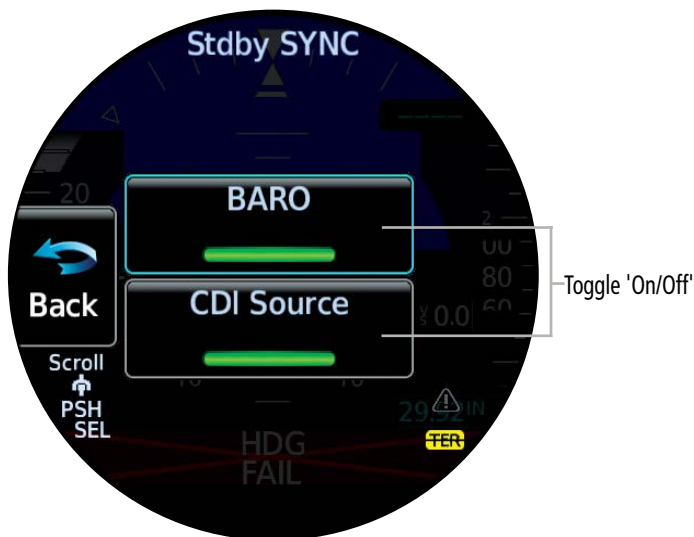

Standby SYNC Control - Standby SYNC Menu - BARO & CDI Source - Active

Side SYNC Control

When properly configured, Side SYNC allows the pilot to sync or un-sync the BARO setting and/or Selected CDI Source between the Pilot and Co-pilot sides of the cockpit. When disabled, the selected setting will only synchronize to units that are configured for the same side. For example, a change on a pilot side unit will synchronize to all other units configured as the 'Pilot' side of the cockpit, but will not sync across to the 'Co-pilot' side of the cockpit.

Enabling Side SYNC Control:

- 1) Press and Hold the Small Knob or Swipe Up on the screen to select **Menu > System > Setup**.

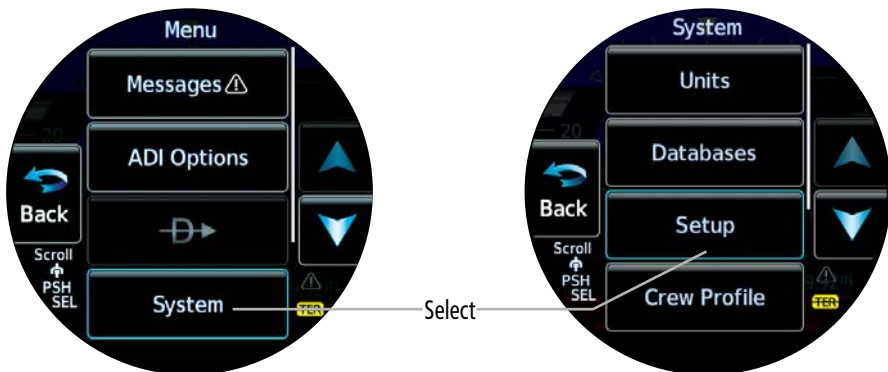

Side SYNC Control - Main Menu & System Menu

- From the Setup menu, select **SYNC Control** > **Side SYNC**.

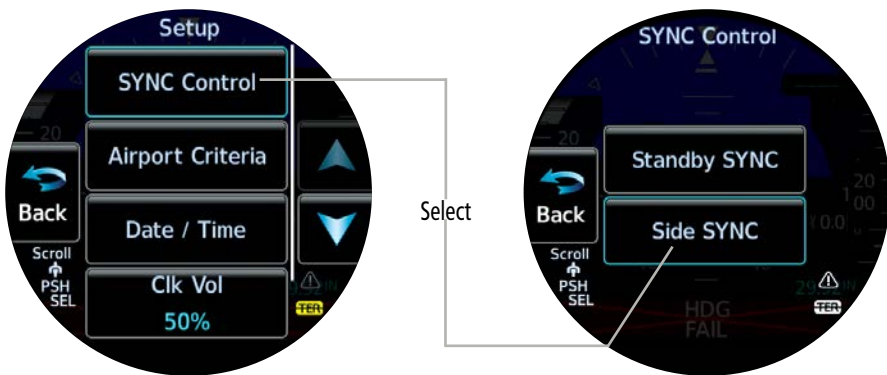

Side SYNC Control - Setup Menu & SYNC Control Menu

- From the Side SYNC menu, select **BARO** and/or **CDI Source**, as desired.

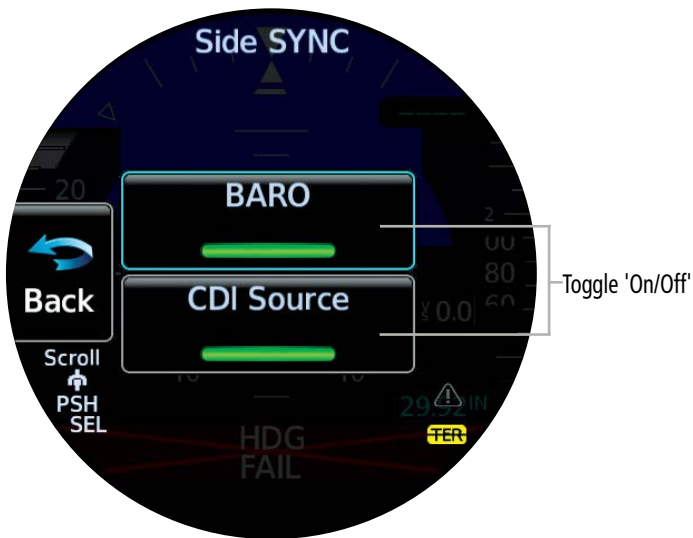

Side SYNC Control - Side SYNC Menu - BARO & CDI Source - Active

- System Overview
- Flight Instruments
- EIS
- Navigation
- Hazard Avoidance
- Autopilot
- WSI
- Additional Features
- Appendices
- Index

HSI (HORIZONTAL SITUATION INDICATOR) PAGE FEATURES



NOTE: Some or all HSI annunciations may appear in the four quadrants of the HSI depending on the external navigator(s) configured (e.g. SL30 NAV/COM Transceiver and/or the GTN or GNS Series Units).



NOTE: When the Navigation Source is VOR/LOC, the distance shown is GPS derived distance to the database location of the displayed VOR or localizer antenna (#6 in the image below).

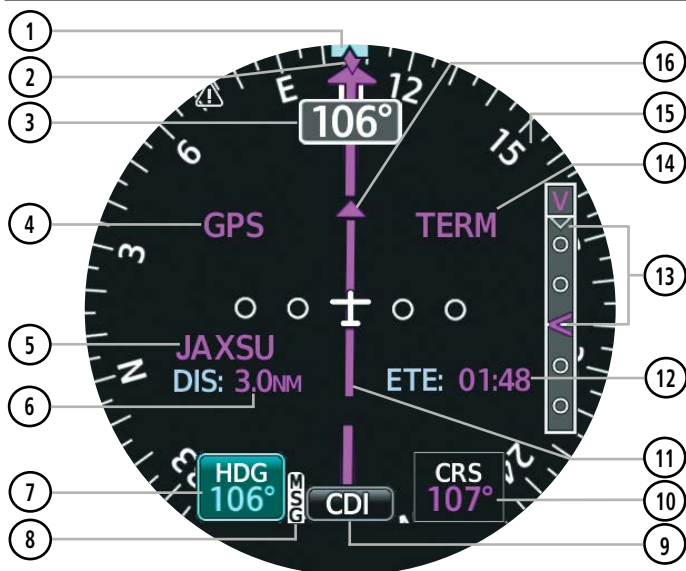

- | | |
|---------------------------------|--|
| ① Selected Heading Bug | ⑨ CDI Source Button |
| ② Current Track | ⑩ Active Course |
| ③ Current Heading | ⑪ Deviation Bar |
| ④ Navigation Source | ⑫ Estimated Time Enroute (ETE) to Waypoint |
| ⑤ Active Waypoint | ⑬ Vertical Guidance |
| ⑥ Distance to Waypoint | ⑭ External Navigator Phase of Flight |
| ⑦ Selected Heading | ⑮ Compass Rose |
| ⑧ Message on External Navigator | ⑯ To/From Indicator |

'HSI' Page Specifics

For all GI 275 products with the following:

- Software version 2.21 or earlier.
- Interfaced with a GTN or GNS series unit.
- Localizer is tuned.
- GPS flight plan is loaded.

The GI 275 provides a distance to the tuned localizer station. It does not provide a distance to the DME station.



NOTE: The distance to the tuned localizer station has been removed for later software versions following 2.21.

Bearing Pointers



NOTE: Bearing pointers are hidden when heading data is unavailable.

Two bearing pointers and associated information can be displayed on the 'HSI' Page for NAV (VOR, Localizer) and GPS sources. The bearing pointers are cyan and are single-line (Bearing Pointer 1) or double-line (Bearing Pointer 2). Pointer symbols are shown above the **HDG** and **CRS** Buttons to indicate the navigation source. The bearing pointers never override the deviation indicator and are visually separated from the deviation indicator by a gray ring shown when the bearing pointers are selected.



'HSI' Page - Bearing Pointers

Enabling/disabling the bearing pointer(s) and changing sources:

- 1) From the 'HSI' Page, open the menu.
- 2) Select the **HSI Options** Button.
- 3) Select **Bearing 1** and/or **Bearing 2** to toggle the visibility of the bearing pointers.
- 4) Select **GPS1** or **NAV1** under **Bearing 1** or **GPS2** or **NAV2** under **Bearing 2**.

2.2 ANNUNCIATIONS AND ALERTING FUNCTIONS

ALTITUDE ALERTING

The Altitude Alerting function provides the pilot with visual and aural alerts when approaching or deviating from the Selected Altitude. Whenever the Selected Altitude is changed, the Altitude Alerter is reset. The following will occur when approaching the Selected Altitude:



NOTE: Depending on configuration at time of installation, an aural tone is generated when passing within either 1000 feet or 200 feet of the selected altitude.

- Passing within 1000 feet of the Selected Altitude, the Selected Altitude (shown above the Altimeter) flashes for 5 seconds and becomes a white box with black numerals.
- When the aircraft passes within 200 ft of the Selected Altitude, the Selected Altitude flashes for 5 seconds to indicate the aircraft is approaching the selected altitude.
- After reaching the Selected Altitude, if the pilot flies outside the deviation band (± 200 Feet of the Selected Altitude), the Selected Altitude changes to yellow text on a black background, flashes for 5 seconds, the altitude bug changes to yellow, and an aural tone is generated.



Altitude Alerting Visual Annunciations

MINIMUM ALTITUDE ALERTING



WARNING: Do not rely on the displayed minimum safe altitude (MSAs) as the sole source of obstacle and terrain avoidance information. Always refer to current aeronautical charts for appropriate minimum clearance altitudes.

For altitude awareness, a barometric or radar minimum altitude bug (e.g., approach minimums, ESA, MOCA, etc.) may be set by the crew and is reset when power is cycled. The bug appears on the altitude tape at the set altitude and is "parked" at the corresponding end of the tape when the bug is beyond the visible range of the tape. When the crew-defined altitude is more than 100 feet away, the bug is cyan. Within 100 feet, the bug is white. Once the aircraft reaches the crew-defined minimum altitude, the bug turns yellow and the MFI generates a "Minimums Minimums" aural alert.

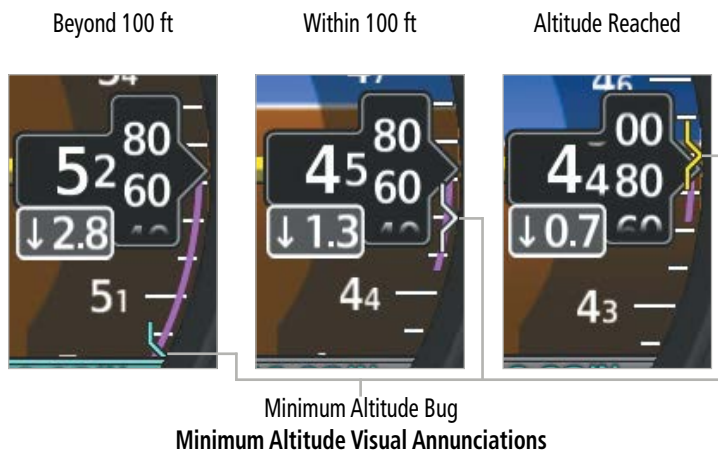

Minimum Altitude Visual Annunciations

Setting the minimum altitude alert:

- 1) From the 'ADI' Page, open the menu and select **ADI Options > Minimums**.
- 2) Enable the **Altitude Minimum Bug** Button.
- 3) Set the altitude source using the Alt Min Source Datafield (barometric or radio altitude).
- 4) Set the minimum altitude using Alt Min Value Datafield.

2.3 ABNORMAL OPERATIONS



NOTE: Interference from GPS repeaters operating inside nearby hangars can cause an intermittent loss of attitude and heading displays while the aircraft is on the ground. Moving the aircraft more than 100 yards away from the source of the interference should alleviate the condition.

ABNORMAL GPS CONDITIONS

If an external GPS navigator fails, the MFI will use the other external GPS navigator (if equipped) as a position source. Should all external GPS sources fail, the MFI will use its internal VFR-only GPS, when configured. When using the VFR GPS, a "VFR GPS is being used" System Message is generated. Should all GPS sources, including the internal VFR GPS fail, "No GPS POS" is annunciated. See the Navigation Section for details.

COMPARATOR ANNUNCIATIONS

Critical values generated by redundant sensors are monitored by comparators. Comparator annunciations appear by the relevant indicator. If differences in the sensors exceed a specified amount, a miscompare annunciation appears as a yellow caution. If one or more of the sensed values are unavailable, a no compare is annunciated as a white advisory. In a three sensor set-up, if a sensor is mis-comparing, only the unit that is mis-comparing will get the yellow annunciation. A white advisory will be cleared after viewing the applicable system message.



NOTE: Operating the system in the vicinity of metal buildings, metal structures, or electromagnetic fields can cause sensor differences that may result in nuisance miscompare annunciations during start up, shut down, or while taxiing. If one or more of the sensed values are unavailable, the annunciation indicates no comparison is possible.



Comparator Annunciations

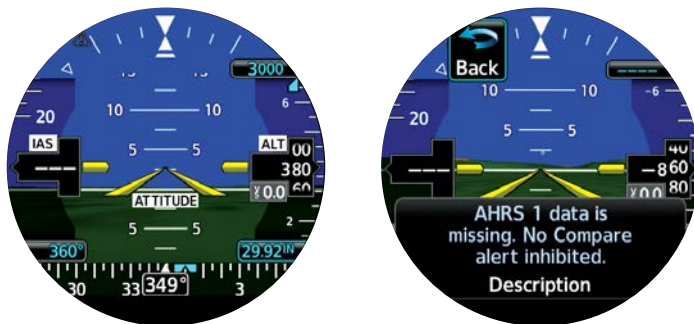

Comparator Annunciations - No Compare & Description

| Comparator Annunciation | Comparator Type | Condition |
|-------------------------|-----------------|--|
| ALT | MISCOMPARE | Altitude sensors disagree. |
| IAS | MISCOMPARE | Airspeed sensors disagree. |
| ATTITUDE | MISCOMPARE | Attitude sensors disagree. |
| ALT | NO COMPARE | No data from at least one altitude sensor. |
| IAS | NO COMPARE | No data from at least one airspeed sensor. |
| ATTITUDE | NO COMPARE | No data from at least one attitude sensor. |

Comparator Annunciations

LOSS OF PRIMARY FLIGHT INFORMATION

If the primary GI 275 ADI fails (loss of some or all primary flight information, display is blank, frozen, or unresponsive).

- 1) Use standby flight instruments for attitude, airspeed, altitude, and heading reference.
- 2) If GI 275 reversionary capability is available, the standby GI 275 should automatically change to the ADI page and promptly restore primary flight information. If manual reversion is required, move the Reversion Backup Switch to the "ON" position.
- 3) Refer directly to the navigation source for navigation information (such as GPS).
- 4) Seek VFR conditions or land as soon as practical.

- If autopilot is engaged, verify autopilot mode selections and cross check against standby flight and navigation data. Consider disengaging the autopilot.

AHRS FAILURE

AHRS failure is indicated by the removal of the attitude/heading information and a red "X" on the GI 275 ADI. Standard rate turn indications will also be removed. A heading failure may also occur.

- Continue flight by reference to the standby ADI or manually select "ON" on the GI 275 reversionary backup switch to force reversion.
- Seek VFR conditions to land as soon as practicable if there are no other reliable AHRS sensors capable of providing accurate data.
- If multiple AHRS sources are installed, select the operative AHRS using the ADI sensors (**MENU > SENSORS**), then press and hold the "Back" button to return to the ADI page.

REVERSIONARY SENSOR ANNUNCIATIONS

If a primary sensor fails or the crew specifies a non-primary sensor, reversionary sensor annunciations appear on the lower portion of the ADI.



Reversionary Sensor Annunciations

| Annunciation | Condition |
|---------------|---|
| ADC 1 | Displaying data from Air Data Computer 1. |
| ADC 2 | Displaying data from Air Data Computer 2. |
| ADC 3 | Displaying data from Air Data Computer 3. |
| AHRS 1 | Displaying data from Attitude and Heading Reference System 1. |

- System Overview
- Flight Instruments
- EIS
- Navigation
- Hazard Avoidance
- Autopilot
- WSI
- Additional Features
- Appendices
- Index

| | |
|---------------|---|
| AHRS 2 | Displaying data from Attitude and Heading Reference System 2. |
| AHRS 3 | Displaying data from Attitude and Heading Reference System 3. |
| ADC 1 | Displaying data from ADC 1 and sensor values disagree. |
| ADC 2 | Displaying data from ADC 2 and sensor values disagree. |
| ADC 3 | Displaying data from ADC 3 and sensor values disagree. |
| AHRS 1 | Displaying data from AHRS 1 and sensor values disagree. |
| AHRS 2 | Displaying data from AHRS 2 and sensor values disagree. |
| AHRS 3 | Displaying data from AHRS 3 and sensor values disagree. |

Reversionary Sensor Annunciations

UNUSUAL ATTITUDES



NOTE: Upon installation, the red recovery chevrons can be configured to 40° or 50° nose UP, and 20° or 30° nose DOWN.

When the aircraft enters an unusual pitch attitude, red extreme pitch warning chevrons pointing toward the horizon are displayed on the Attitude Indicator, starting at 40° above and 20° below the horizon line, or 50° above and 30° below the horizon line, depending on configuration. During extreme pitch attitudes, the display shows either a brown or blue colored bar at the top or bottom of the screen to represent earth or sky. The blue colored bar is also displayed when terrain gradient is great enough to completely fill the display. This is intended to prevent losing sight of the horizon during extreme pitch attitudes.

If pitch exceeds +30°/-20° or bank exceeds 65° (45° on sky pointer), some displayed information is removed. The Altimeter and Airspeed, Attitude, and Vertical Speed indicators remain on the display. The following information is removed from the ADI (and corresponding controls are disabled) when the aircraft experiences unusual attitudes:

- Vertical Deviation Indicator
- Selected Altitude
- Standard rate turn indicators
- Altimeter barometric setting
- Heading data
- GPS navigation status
- Menus



Unusual Attitudes - SVT Disabled



Unusual Attitudes - SVT Enabled

SMART GLIDE ACTIVATION

The GI 275 follows the GTN Xi commands upon Smart Glide activation when interfaced with a compatible GTN Xi. The GI 275 conducts the following upon Smart Glide activation:

- Dashes within the Preselected Altitude Field.
- Changes the Indicated Airspeed (IAS) bug to the best glide speed, as configured for the aircraft.
- Changes the selected Nav source to the configured GTN, which activates the Smart Glide sequence, i.e. GPS1.
- Annunciates "GLIDE" in a yellow box below the Altitude Preselect field.



NOTE: If the GI 275 is controlling a GFC500 Autopilot, the GI 275 engages the GFC500 and will set the GFC500 Modes according to the options commanded from the GTN Xi.

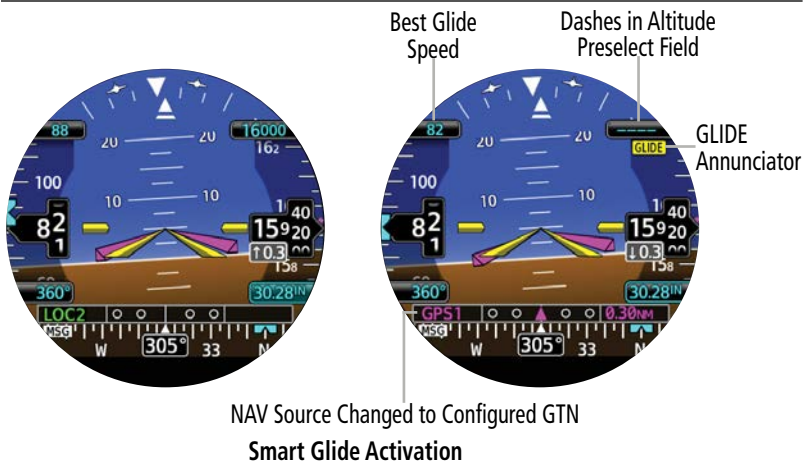

SECTION 3 ENGINE INDICATION SYSTEM

3.1 INTRODUCTION



NOTE: Fixed wing configurations only.



NOTE: The display of Engine Indication System Pages depends upon the current configuration and may vary from the examples discussed in this section.



NOTE: When configured as a Primary EIS, a half screen menu is available and individual page options are accessed via the generic Options Button. When configured as a Standby ADI or as an MFD, a full screen menu is available and individual page options are accessed via the page-specific Options button (e.g. Fuel Options Button on the 'Fuel' Page Menu). Page titles may vary depending on configuration as well.

Engine Indication System (EIS) Pages can display engine, fuel, electrical, and other system parameters. A variety of gauge and indicator types (analog indicators, digital data fields, bar graphs, horizontal and vertical bar indicators) are used to display EIS information. Primary Gauges which must be displayed during all phases of flight, such as RPM and Manifold Pressure (if applicable) are displayed at the top of each EIS Page. Fuel Quantity is displayed at the bottom of the EIS Page, and will always be visible on top of the Menu when opened for Primary EIS.

The 'Main' EIS Page displays all of the alerting gauges. The 'AUX' Page is available for non-alerting gauges which do not fit on the 'Main' Page, as well as pilot configurable gauges for additional information. Additionally, other EIS Pages are available based on the sensor configurations, such as the CHT/EGT Page with lean assist capabilities. Fuel Summary Page if a Fuel Flow is configured, and a Flight Summary Page that lists details in real-time for certain engine parameters. See the EIS Pages portion of this section for more information.

Engine data is constantly being monitored, regardless of the current page displayed. If any exceedance of engine parameters (according to the configuration) occurs, a pop-up alert will be issued so the condition can be quickly reviewed by the pilot. For more information on EIS alerts and annunciations, see the EIS Alerts portion at the end of this section.

START-UP SCREEN

A start-up screen displays Flight, HOBBS, and Tach hours, along with the **Fuel Remaining** Button. Flight hours are metered when airborne; if the MFI is not able to assess the air/ground state, flight hours are metered when the engine RPM exceeds 1,250 RPM, this value is configurable at the time of installation. HOBBS hours are metered any time engine oil pressure exceeds 5 psi. Tach hours are metered any time the engine has a positive RPM. Tach hours are incremented with the current engine RPM in proportion to the aircraft cruise RPM value set during installation. Flight, HOBBS, and Tach hours can also be viewed in the system menu.

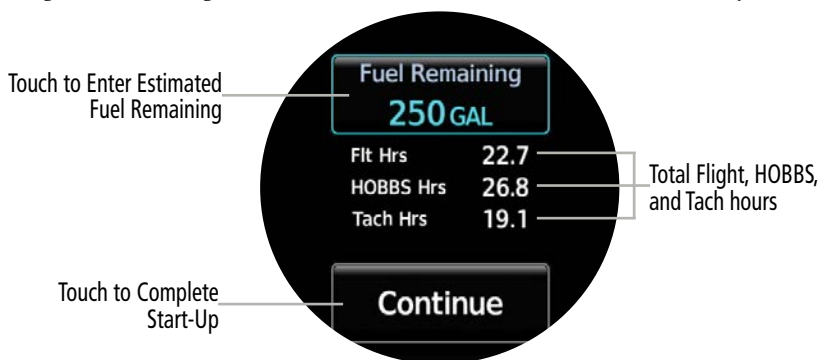

EIS Start-up Screen

NOTE: The EIS Start-up Screen will not be displayed if the GI 275's system believes the aircraft is airborne and/or during the previous power cycle, the system was shut down in an airborne logic state.

Entering fuel remaining on start-up screen:

- 1) Power on the MFI. The EIS start-up screen is displayed.
- 2) Select the **Fuel Remaining** Button.
- 3) Use the keypad to enter the estimated fuel on board.
- 4) Select the **Enter** Button to confirm the entry and return to the start-up screen.
- 5) Select the **Continue** Button to complete start-up.

3.2 GAUGE AND INDICATOR TYPES

NOTE: Display indications depend upon the current configuration and may vary from the examples discussed in this section.

NOTE: For aircraft equipped with a starting vibrator, the RPM reading is not accurate during engine cranking. For aircraft that measure engine RPM using P-lead sensors, the reading may momentarily fluctuate when selecting operation on a single magneto.

Gauge format and page layout vary depending on configuration. RPM and Manifold Pressure (if applicable) will be displayed at the top of every EIS Page, Fuel Quantity will be displayed at the bottom of every EIS Page. Units of measure, limits, and gauge colors are configured during installation.

Digital Values may be displayed in white text. The color green indicates normal ranges of operation. For a gauge with a green range, white or uncolored markings indicate operating ranges not considered cautionary.

Yellow radial line or range denotes a caution range. Red minimum/maximum line or range denotes a limitation. For information on annunciators and flashing color or text, see the EIS Alerts portion at the end of the EIS Section.

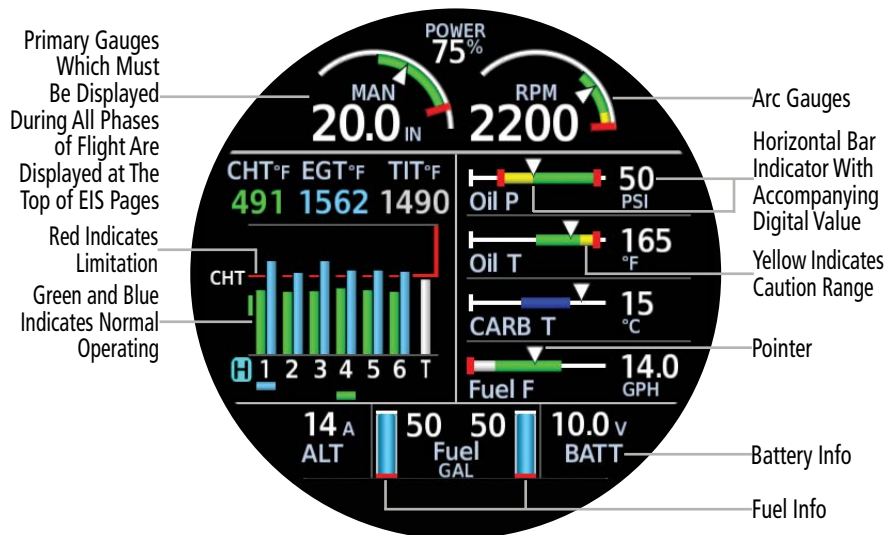















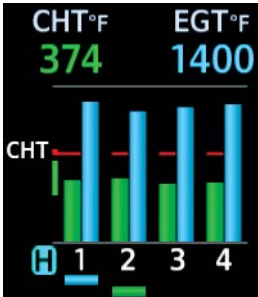

Main Page – Example Configuration

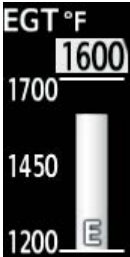
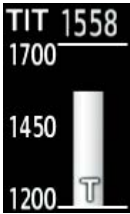
The Tachometer (RPM) and Manifold Pressure (MAN) Gauges are always displayed as arc gauges, and the Fuel Quantity gauges are displayed as beaker gauges. The Battery Voltage/Amps and Bus Voltage/Amps are always displayed as a digital value. The CHT/EGT/TIT/Primary EGT are always displayed as part of the bar graph. All other gauges are displayed as strip gauges. Other indications may display pointers, digital values, curves, or behavior bands.

The Main page bar graph (CHT, EGT, and dual TIT) will display the hottest cylinder, and this value has a small hysteresis to stabilize jumpiness, leading to the chance the cylinders might be within 3 degrees before changing to a hotter cylinder. The user can always use the small knob and select a specific cylinder to display the associated temperature. If the EIS is configured for Single Cylinder EGT/CHT, the bar graph is replaced with a single strip gauge for EGT and CHT, respectively.

The Carburetor Temperature (Carb T) gauge should be configured to display Blue for the temperature range (°C) most susceptible to the development of carburetor ice. The following table provides an example of the different kind of gauge and indicator types. This list is not all inclusive; gauge and indication display depend on configuration.

| Type | Example |
|--|---|
| Tachometer (RPM) |  |
| Manifold Pressure Gauge |  |
| Oil Pressure |  |
| Oil Temperature |  |
| Fuel Pressure |  |
| Fuel Flow |  |
| Fuel Quantity |  |
| Cylinder Head Temperature (CHT) Exhaust Gas Temperature (EGT) |  |
| Single Cylinder Head Temperature (CHT) |  |

| Type | Example |
|--|---|
| Single Exhaust Gas Temperature (EGT) |  |
| Primary Exhaust Gas Temperature (PEGT) |  |
| Turbine Inlet Temperature (TIT) |  |
| Inlet Air Temperature (IAT) |  |
| Compressor Discharge Temperature (CDT) |  |
| IAT CDT Temperature Differential |  |
| Alternator AMPS |  |
| Battery AMPS |  |
| Bus Voltage |  |
| Battery Voltage |  |
| Carburetor Temperature |  |

Example Gauge and Indicator Types

BAR GRAPH INDICATIONS

When configured for 4, 6, or 7 cylinder engines, EGT and CHT information is displayed as a bar graph. When configured for single (1) cylinder engines, this bar graph is replaced with a single strip gauge for EGT and CHT, respectively. Information for each cylinder is shown which can be useful for observing engine indications and performing leaning procedures. Each bar graph contains the following components:

- Dynamic chart depicting cylinder temperature status
- Digital temperature reading of each cylinder
- Limit markings

The size of each graph varies based on engine specifications (i.e. the number of cylinders per engine) and gauge configuration (i.e., TIT or primary EGT).

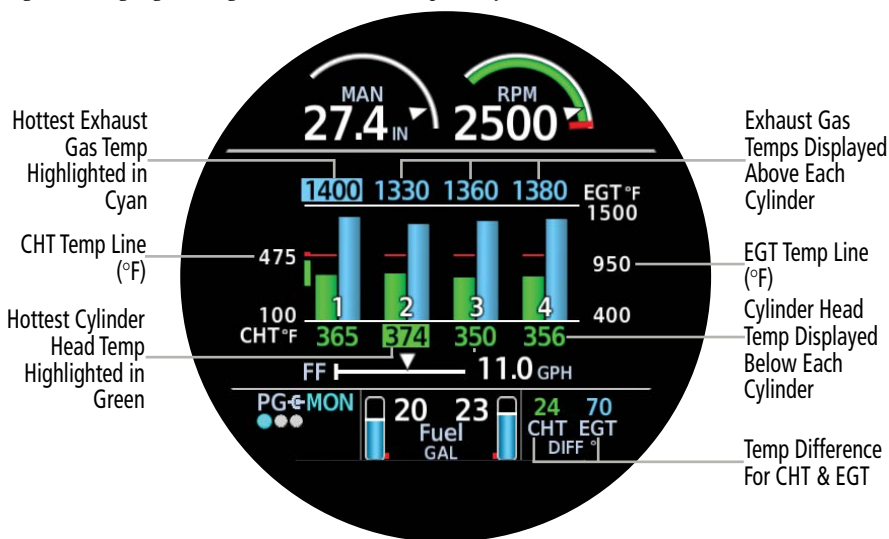

CHT/EGT - Four Cylinders - Bar Graph Example

PERCENT POWER INDICATIONS

Depending on the configuration, calculated Percent Power can be displayed at the top of each EIS Page. Using sensor readings, this provides an estimated percentage of the maximum engine power for the current engine power settings. This can also be displayed on the AUX Page. Please see the AUX Page in the EIS section.

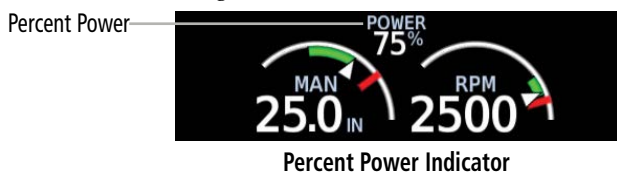

Percent Power Indicator

MULTI-ENGINE INDICATIONS

Display of EIS information for multi-engine aircraft requires one MFI per engine.

Propeller Sync Indicator

A Propeller Sync Indicator can be displayed at the top of each EIS Page. The indicator spins in the direction of the higher-speed propeller when the propellers are out of sync. When two or more MFIs are configured to show EIS, the propeller sync indicator need only be displayed on one MFI.

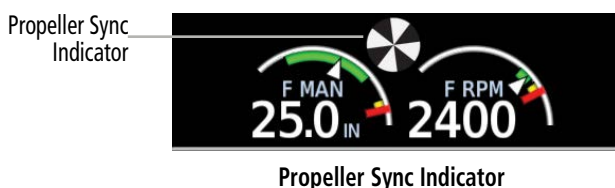

Propeller Sync Indicator

3.3 EIS PAGES



NOTE: Display indications depend upon the current configuration and may vary from the examples discussed in this section.

The EIS can display and monitor engine performance and power. Only a set amount of data is displayed on one page at a time in order to improve pilot monitoring and reduce workload. This section will cover the individual pages which may be available, depending on configuration.

MAIN PAGE

All alerting gauges are displayed on the 'Main' Page (when the MFI is configured as an MFD or Standby ADI, this page may, instead, be labeled 'Main EIS' Page). An alerting gauge is any gauge with cautionary (yellow) or limitation (red) indications. See the EIS Alerts portion later in this section for more information on alerts. Shunt and Bus Digital Values may also be displayed on the 'Main' Page. The GI 275 EIS has a quick press button to move between different pages, rather than using the knob. While on the Main EIS Page, pressing the CHT/EGT graph will navigate the user to the CHT/EGT page. Pressing the Fuel indicator at the bottom on any page will navigate the user to the Fuel Summary Page. Pressing the top of the screen (Manifold or RPM) gauges will navigate the user back to the Main Page.

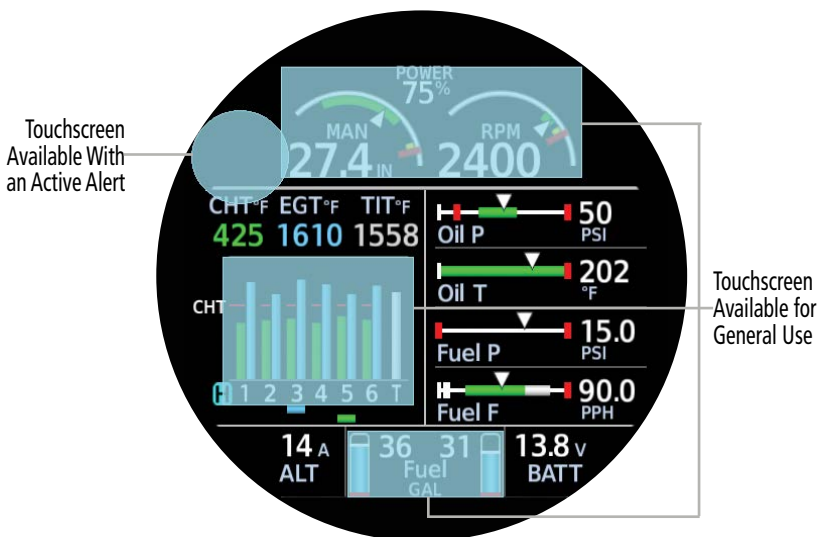

Main Page - Touchscreen Areas

CHT/EGT Graph Functions



NOTE: The GI 275 can be configured to display a single CHT/EGT with the corresponding single strip gauges on the Main EIS Page. In this configuration, the traditional CHT/EGT Page and the associated modes (lean assist, normalization, monitor) will **not** be available.

The CHT/EGT graph on the Main EIS Page shows the hottest temperatures in the digital readouts above the graph when the 'H' is selected (as indicated by the cyan highlight). Individual cylinders (or TITs) can be selected for display by turning the Small Knob. These selections will timeout and return to the hottest after a period of inactivity as determined by the Field Timeout. To help associate the readout currently being displayed with the bar, a color coordinated line moves under the bar corresponding to the readout. Unacknowledged alerts for this graph will take priority over any selection.

Primary Gauges Which Must be Displayed During All Phases of Flight Are Displayed at The Top of EIS Pages

Current Selection Highlight

Left Auxiliary Fuel (Gals)

Left Main Fuel (Gals)

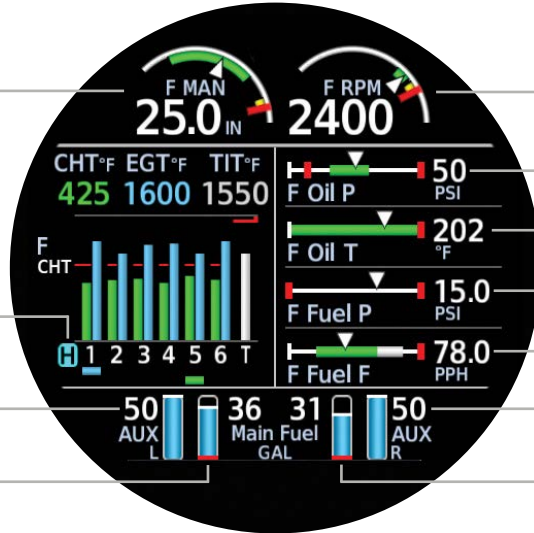

Front Engine RPM

Oil Pressure

Oil Temp

Fuel Pressure

Fuel Flow

Right Auxiliary Fuel (Gals)

Right Main Fuel (Gals)

Main Page - Multi Engine - Centerline Thrust

Manifold Pressure (IN)

Single Cylinder Head Temp.

Single Exhaust Temp.

Current Time

Left Main Fuel (Gals)

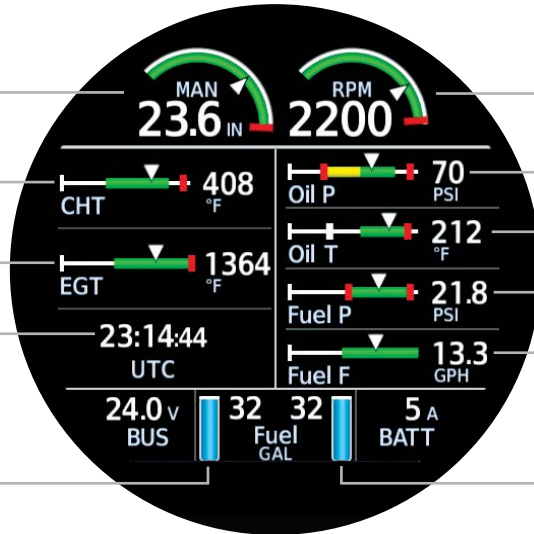

Engine RPM

Oil Pressure

Oil Temp

Fuel Pressure

Fuel Flow

Right Main Fuel (Gals)

Main Page - Single CHT/EGT

Carburetor Temperature Gauge (Optional)



NOTE: *If applicable, it is recommended to configure the Carburetor Temperature gauge to display Blue for the temperature range (°C) most susceptible to the development of icing.*

The Carburetor Temperature (Carb T) gauge should be configured to display Blue for the temperature range (°C) most susceptible to the development of carburetor ice. When the pointer is outside of the Blue range, the chance of carburetor icing is low. When the pointer is within the Blue range, the chance of carburetor icing is higher, and applying carburetor heat is recommended to avoid and/or prevent degradation of aircraft performance related to carburetor icing.



Carburetor Temperature Gauge

Advisory Options

Pilot-defined advisories can be created for certain engine parameters. Advisory options may be adjusted, enabled, or disabled. Access Advisory Options via the page menu on the 'Main' Page.

Pilot-defined advisories can be set for any value within the indicator's range, regardless of pre-configured warning (red) and caution (yellow) limitations. Enabling a pilot-defined advisory does not affect pre-configured warning and caution alerting behavior. See the EIS Alerts portion of this section for more information on warning and caution alerting.

Advisory options are determined by configuration, and may include the following:

- High CHT
- High EGT Differential
- High TIT
- Low Battery Voltage
- Low Oil Temperature
- High Battery Voltage
- High Oil Temperature
- Low Fuel Reserve
- High Bus Voltage
- Low Estimated Fuel
- Low Bus Voltage
- High Fuel Differential
- High CHT Cooling Rate

When an advisory parameter has been exceeded, an advisory message will be issued. Advisories can be acknowledged in the same manner as other system messages.

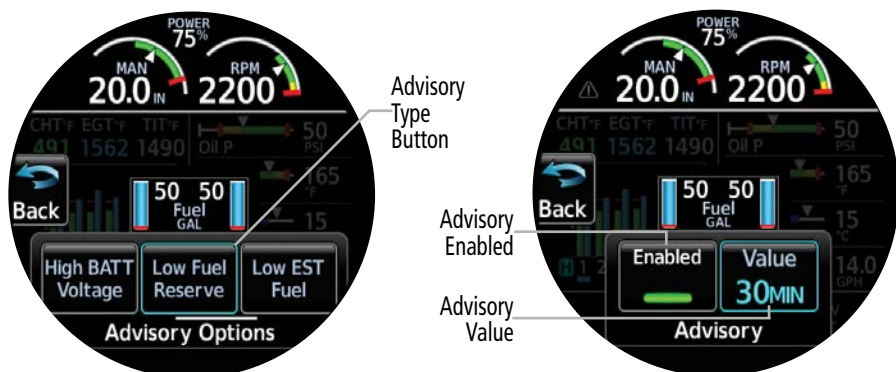

Advisory Options

Adjusting engine advisory settings:

- 1) From the 'Main' Page, open the page menu and select **Options**.
- 2) Select the desired Advisory Type Button.
- 3) Select the **Value** Button and use the Small Knob to enter the advisory value, then select the **Enter** Button to confirm the entry.

Enabling/disabling an engine advisory:

- 1) From the 'Main' Page, open the page menu and select **Options**.
- 2) Select the desired Advisory Type Button.
- 3) Select the **Enable** Button to enable or disable the advisory. The advisory is enabled when the annunciator bar is green.

AUX PAGE

Additional gauges which do not fit on the 'Main' Page and are not alerting gauges, display on the 'AUX' Page (when the MFI is configured as an MFD or Standby ADI, this page may, instead, be labeled 'AUX EIS' Page). Advisory Options may be accessed from the page menu on this page as well. Up to four pilot-defined data buttons can be displayed on this page if the space is not required for gauges based on the installation. Data options are determined by configuration, and may include the following:

- CHT Differential
- Density Altitude
- Destination ETA
- Distance
- Endurance
- Estimated Fuel Remaining
- Estimated Time Enroute (ETE)
- Fuel at Destination
- Fuel Used
- Ground Speed
- Outside Air Temp
- Range
- TACH Time
- Clock
- Destination Distance
- Destination ETE
- EGT Differential Temp
- Endurance at Destination
- Estimated Time of Arrival (ETA)
- Flight Time
- Fuel Efficiency
- GPS Altitude
- HOBBS Time
- Percent Power
- Range at Destination
- AUX Fuel

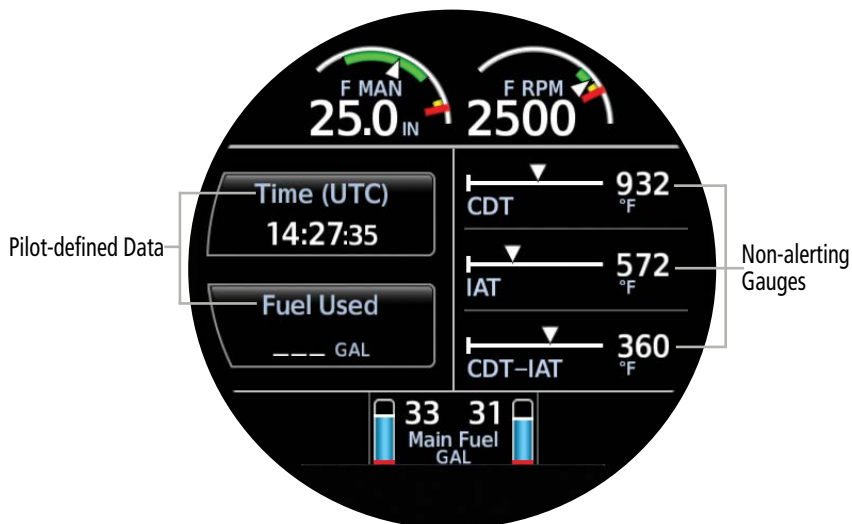

AUX Page - General

- System Overview
- Flight Instruments
- EIS
- Navigation
- Hazard Avoidance
- Autopilot
- WSI
- Additional Features
- Appendices
- Index

If the GEA is interfaced to a GTP59 Outside Air Temperature (OAT) probe, the OAT can be selected in the AUX page button options. This value represents the Total Air Temperature (TAT) that is sourced through the engine adapter.

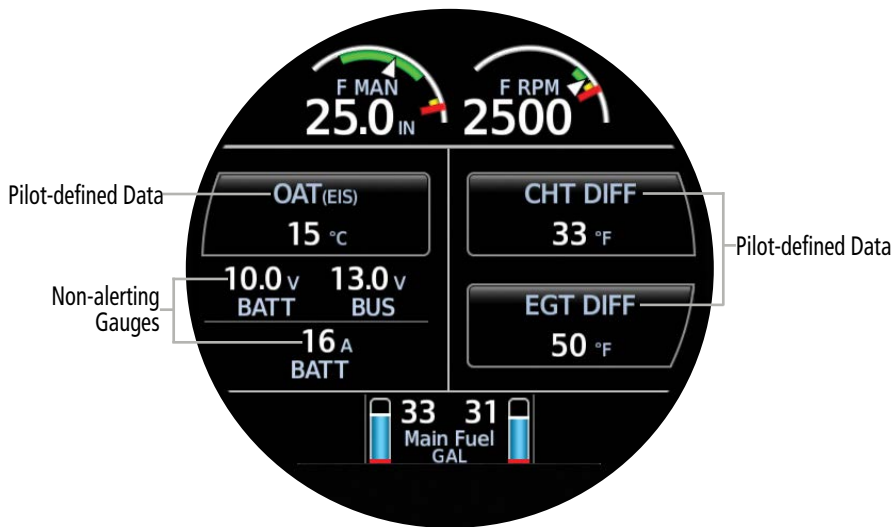

AUX Page - OAT (Optional)

CHT/EGT PAGE



NOTE: The GI 275 can be configured to display a single CHT/EGT with the corresponding single strip gauges on the Main EIS Page. In this configuration, the traditional CHT/EGT Page and the associated modes (lean assist, normalization, monitor) will **not** be available.

The 'CHT/EGT' Page graphically displays CHT (green) and EGT data (cyan) for each cylinder. Graduations are scaled and sized during installation. Other data which may be displayed includes: Fuel Flow, TIT, or Primary EGT information, depending on the configuration. The page supports three modes:

- Monitor
- Lean Assist
- Normalization

The mode can be selected by rotating the smaller knob, or via the page menu options. When the mode is changed, a banner momentarily displays the new mode.

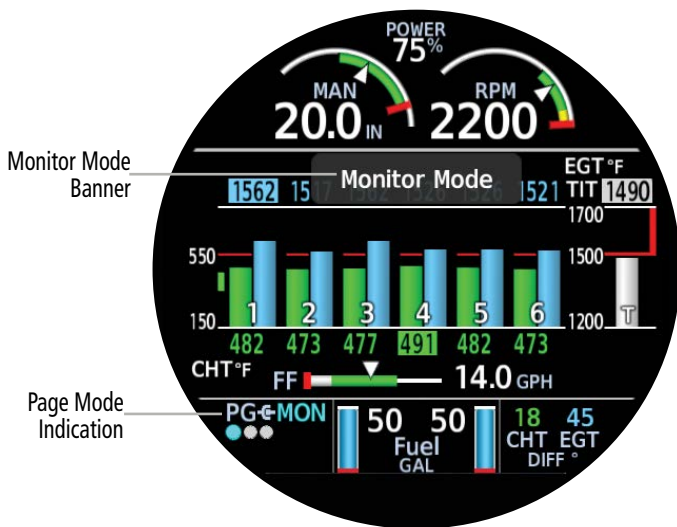

CHT/EGT - Page Mode - Monitor Mode Banner

Monitor Mode

In "MON" mode, the CHT/EGT page displays the current CHT/EGT temperatures, any TIT or Primary EGT temperatures, and the current Fuel Flow.

Measured CHT is displayed in green below each bar, and the hottest cylinder is automatically detected and shown in black on a green background.

Measured EGT is displayed in cyan above each bar, and the hottest cylinder is automatically detected and shown in black text on a cyan background.

If available, TIT or Primary EGT will be displayed digitally and within the graph at the right side as a grey bar labeled 'T' or 'E', respectively.

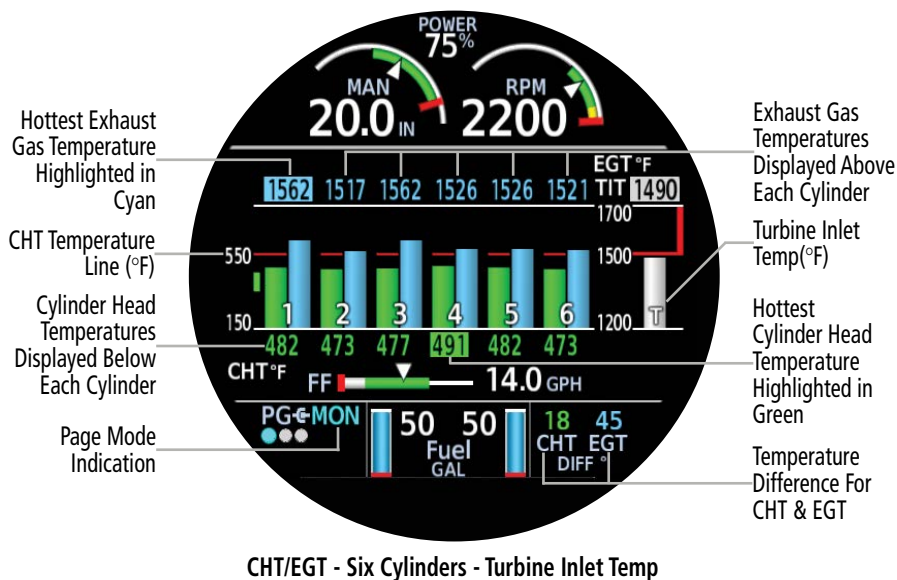

- System Overview
- Flight Instruments
- EIS
- Navigation
- Hazard Avoidance
- Autopilot
- WSI
- Additional Features
- Appendices
- Index

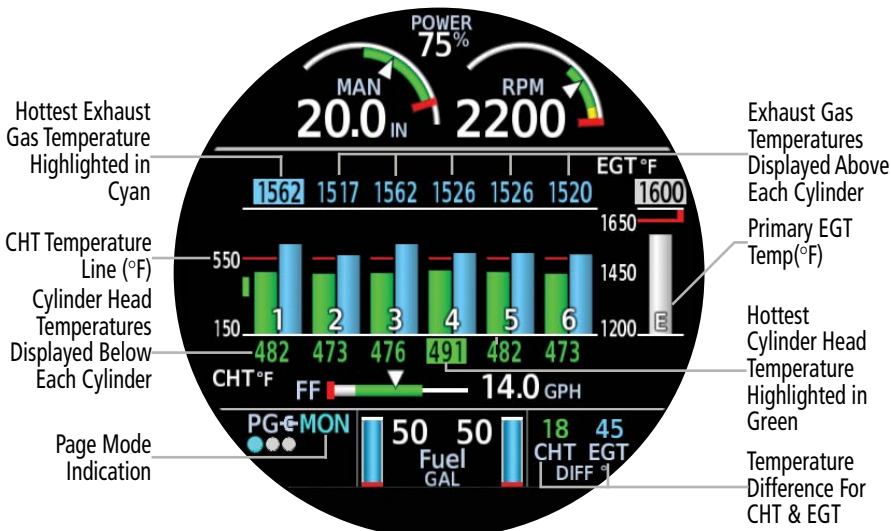

CHT/EGT - Six Cylinders - Primary EGT Temp

A single barbed dark blue arrow represents shock cooling at a rate of 30°F / minute.

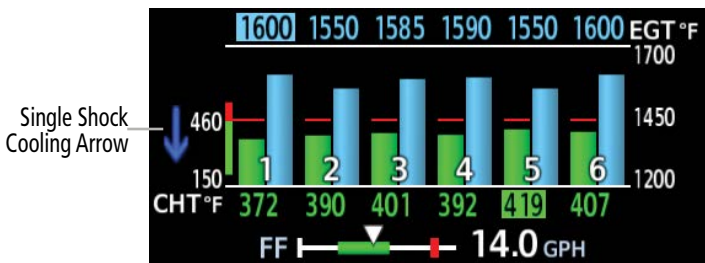

CHT/EGT - Shock Cooling - Single Arrow

A double barbed dark blue arrow represents shock cooling at a rate of 60°F / minute.

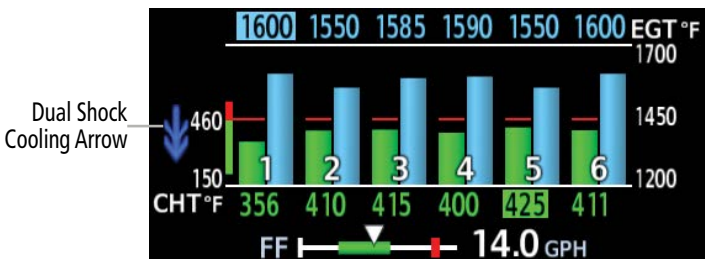

CHT/EGT - Shock Cooling - Double Arrow

Lean Assist Mode

In Lean Mode, the CHT/EGT page displays markings above each cylinder to indicate peak temperatures during leaning operations.



NOTE: See the current, pertinent flight manual for specific engine leaning procedures

Lean Assist functions can be activated by selecting the Lean Mode page. The lower right-hand corner of the screen will provide a status indication of the lean.

STATUSES:

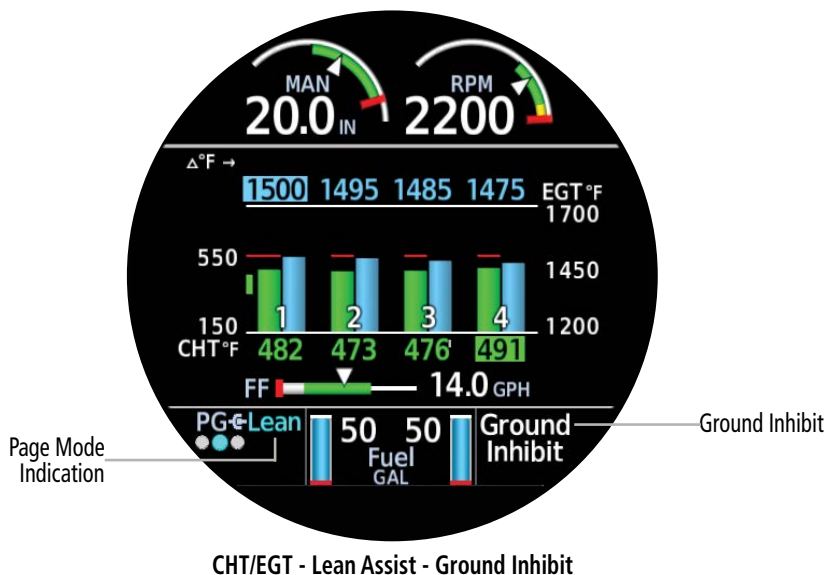

- Ground Inhibit: Lean Assist isn't supported while the aircraft is on the ground.
- Ready to Lean: The Lean Assist has begun and is monitoring the engine data.
- Looking for Peak: At least one cylinder has increased in temperature and is being monitored for a peak.
- First Peak: The first peak was detected.
- Last Peak: The last peak was detected.
- Peak Δ : The difference between the cylinder's current temperature and the peak temperature for the first or last cylinder to peak.

- System Overview
- Flight Instruments
- EIS**
- Navigation
- Hazard Avoidance
- Autopilot
- WSI
- Additional Features
- Appendices
- Index

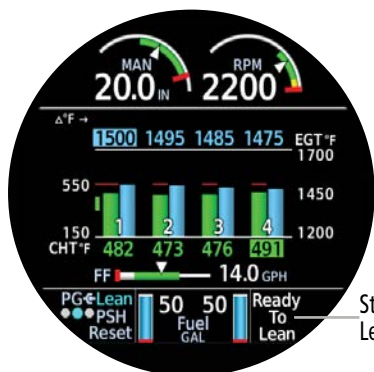

Start of Lean

1 - Start of Lean Process

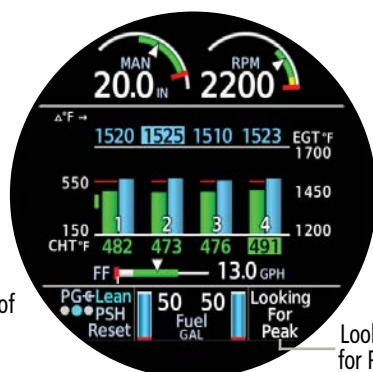

Looking for Peak

2 - Looking for Peak

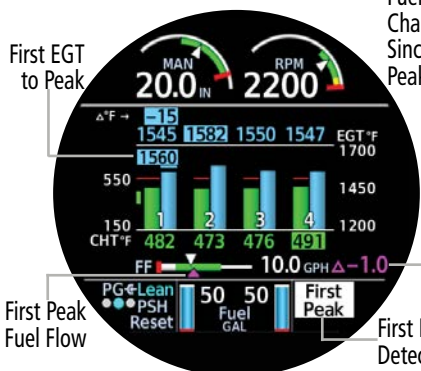

First EGT to Peak

Fuel Flow Change Since 1st Peak

First Peak Fuel Flow

First Peak Detected

3 - Temp Rise Detected

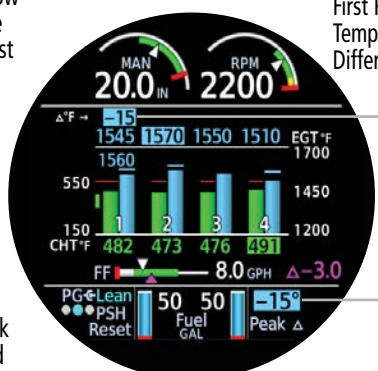

First Peak Temp Difference

4 - First Peak Temp Difference

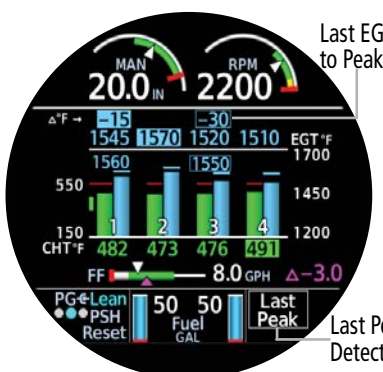

Last EGT to Peak

Last Peak Detected

5 - Last Peak Detected

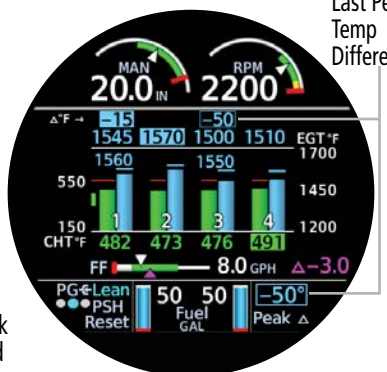

Last Peak Temp Difference

6 - Last Peak Temp Difference

CHT/EGT - Lean Assist Indications

Depending on the configuration, Lean Assist will monitor either the Exhaust Gas Temperatures (EGT) or the Turbine Inlet Temperatures (TIT), and provide Lean Assist indications accordingly.

Once the temperature rises, peaks, or decreases, as configured by the system, peak temperature is determined, and the following will occur:

- The peak temperature will be indicated above the corresponding cylinder bar with a cyan line for EGT, or gray line for TIT.
- If enough space is available on the display, the peak temperature will be displayed above the line.
- The difference between the cylinder's current temperature and the peak temperature is displayed above the current temperature for the first, in black text on a cyan background, and last cylinder, in cyan text with a cyan box around it, to peak.

Once a peak occurs, the Fuel Flow gauge below the graph will display a magenta triangle indicating the fuel flow when the first or last cylinder peaked. The difference in the current fuel flow and the peak fuel flow will be shown to the right of the gauge.

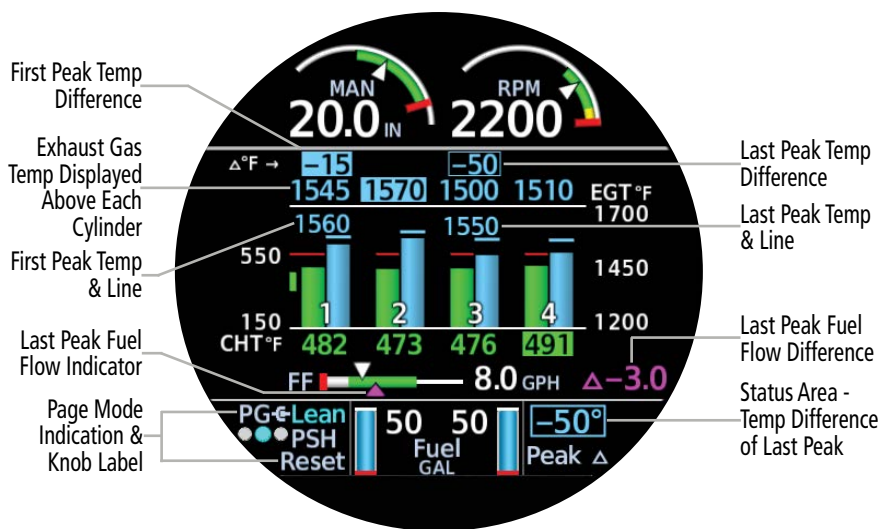

CHT/EGT - Lean Assist Mode

If a Lean Assist Reset is necessary, press the Knob and confirm Reset.



CHT/EGT - Lean Assist Reset

Lean Assist Alerts

Lean alert settings may be adjusted, enabled or disabled. Depending on the sensors available, the alerts will either provide a change in temperature alert or a Rich of Peak (ROP)/Lean of Peak (LOP) alert. When the alert is triggered the “Peak Δ ” status value will be highlighted.

The change in temperature alert will occur when the first engine cylinder to peak’s Exhaust Gas Temperature has changed from its peak temperature by the specified temperature.

The Rich of Peak (ROP) alert will occur when the first engine cylinder to peak’s Exhaust Gas Temperature has changed from its peak temperature by the specified temperature and the Fuel Flow is above its peak fuel flow (rich of peak).

The Lean of Peak (LOP) alert will occur when the last engine cylinder to peak’s Exhaust Gas Temperature has changed from its peak temperature by the specified temperature and the Fuel Flow is below its peak fuel flow (lean of peak).

Touch to View Previous Screen

Back

Alert Mode

Mode
Lean

Alert 1
30°F ROP

Alert 2
40°F ROP

Touch to Adjust Alert 1

Touch to Adjust Alert 2

CHT/EGT Options

CHT/EGT - Rich of Peak & Lean of Peak Alert Options

Touch to View Previous Screen

Back

Alert 1 Enabled

Enabled

Degrees
30°F

Type
ROP

Touch to Adjust Alert 1

Touch to Adjust Type of Alert

Alert 1 Options

CHT/EGT - Rich of Peak Alert Options

- System Overview
- Flight Instruments
- EIS
- Navigation
- Hazard Avoidance
- Autopilot
- WSI
- Additional Features
- Appendices
- Index

Touch to View Previous Screen

Back

Alert Mode

Mode **Lean**

Alert 1 30°F ΔT

Alert 2 40°F ΔT

Touch to Adjust Alert 1

Touch to Adjust Alert 2

CHT/EGT Options

CHT/EGT - Peak Alert Selection

Touch to View Previous Screen

Back

Peak Alert 1 Enabled

Enabled

Degrees

Alert 1 30°F

Touch to Adjust Alert 1

Alert 1 Options

CHT/EGT - Peak Alert 1 Settings



CHT/EGT - Lean Assist Alert Indication

Adjusting lean alert settings:

- 1) From the CHT/EGT Page, open the page menu and select **Options**.
- 2) Select the desired **Alert** Button.
- 3) Select the **Degrees** Button and use the Small Knob to enter the degree difference from Peak for the alert setting. Then, select the **Enter** Button to confirm the entry.
- 4) If available, select the **Type** Button to toggle between the ROP and LOP alert type.

Enabling/disabling lean alert settings:

- 1) From the CHT/EGT Page, open the page menu and select **Options**.
- 2) Select the desired **Alert** Button.
- 3) Select the **Enabled** Button to enable or disable the alert. The alert is enabled when the annunciator bar is green.

Normalization Mode

In NRM Mode, the CHT/EGT Page displays the Cylinder Head Temperatures, Exhaust Gas Temperatures, and any TIT or Primary EGT temperatures relative to a normalized value. The bars of the graph and the digital values display the temperature difference from the normalized value

Normalized values can be activated by selecting the page NRM Mode.



CHT/EGT - Normalization Mode

On the Normalization page, yellow and redline markings are not shown but the gauge will change color to alert the user if the threshold is exceeded.

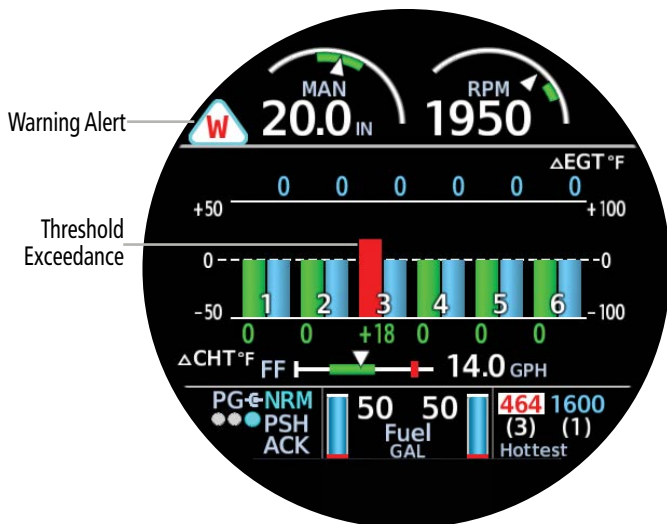

CHT/EGT - Normalization Mode - Threshold Exceedance

Resetting Normalized Value:

Press the knob and confirm to reset the normalized temperature baseline values to the current values.

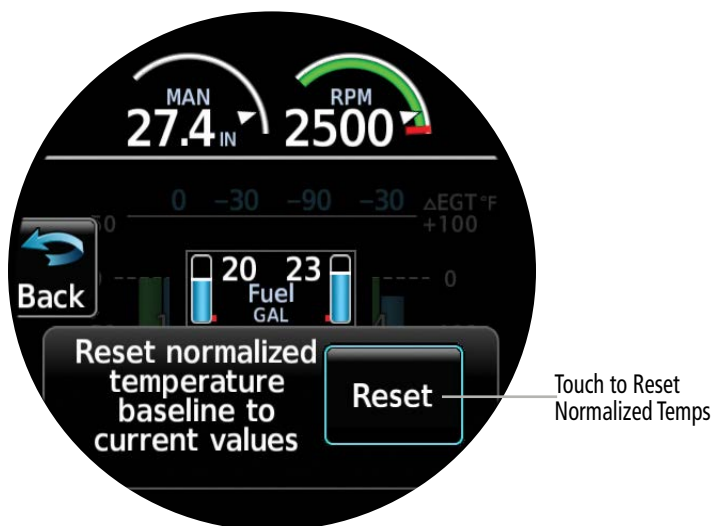

CHT/EGT - Normalized Temperature Reset

FLIGHT SUMMARY PAGE

The Summary Page graphically displays a collection of data obtained during the last flight. The information displayed will vary depending on the configuration. The page supports three sub-pages of data:

- Aircraft Timers
- RPM and Temp Data
- Fuel and Lean Data (only available when a fuel flow sensor is properly installed and configured)

The sub-pages can be selected by rotating the smaller knob.

- System Overview
- Flight Instruments
- EIS
- Navigation
- Hazard Avoidance
- Autopilot
- WSI
- Additional Features
- Appendices
- Index

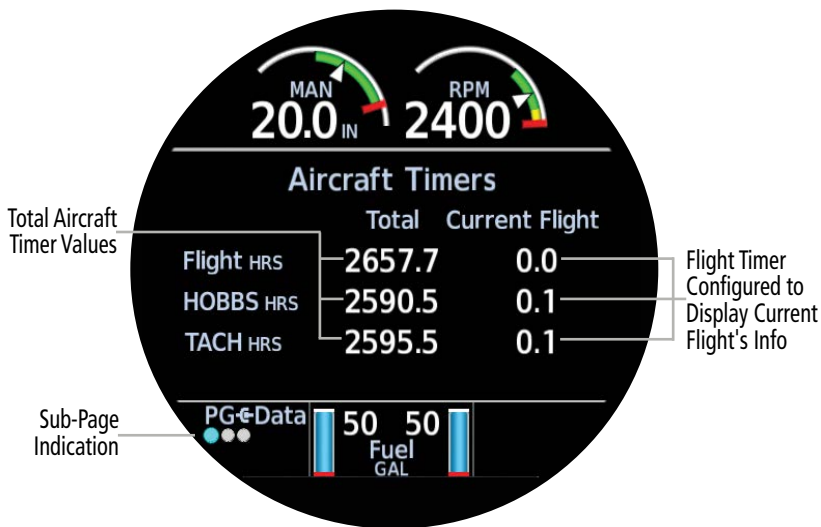

Flight Summary - Aircraft Timers

Total Aircraft Timer Values

Total Current Flight

Flight Timer Configured to Display Current Flight's Info

Sub-Page Indication

Maximum Values for Current Flight

Sub-Page Indication

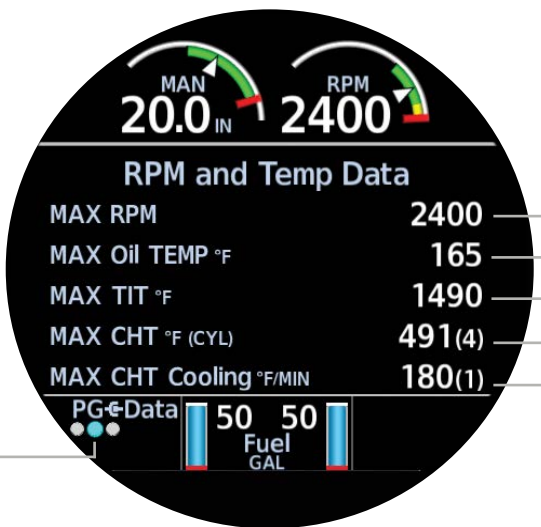

Flight Summary - RPM & Temp Data

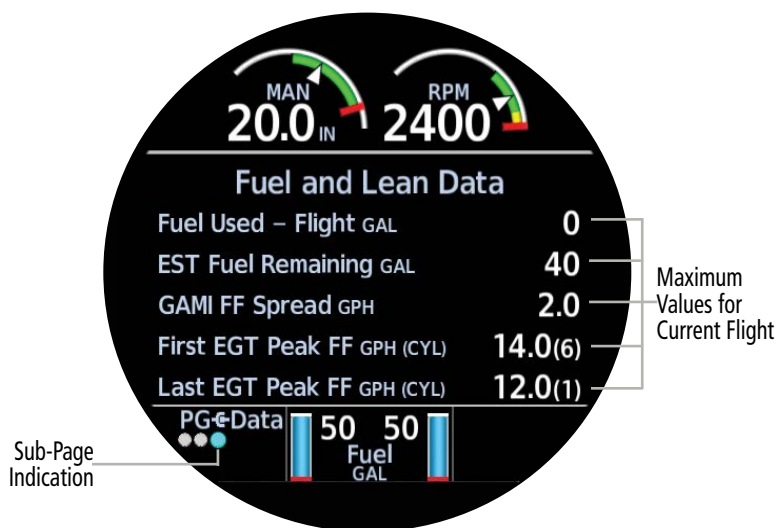

Flight Summary - Fuel & Lean Data

Resetting Flight Summary Data:

- 1) From the Summary Page, open the menu and select **Options**.
- 2) Select the **Reset Summary** button to reset the Flight Summary data, which includes Current Flight Timers, Max RPM and Temp Data, and Fuel and Lean Data.



Reset Flight Summary

FUEL PAGE

The 'Fuel' Page displays fuel calculations based on the Estimated Fuel Remaining and GPS ground speed. Estimated Fuel Remaining is input by the pilot at start-up or via the **Fuel EST** Button on the Fuel Options Menu.

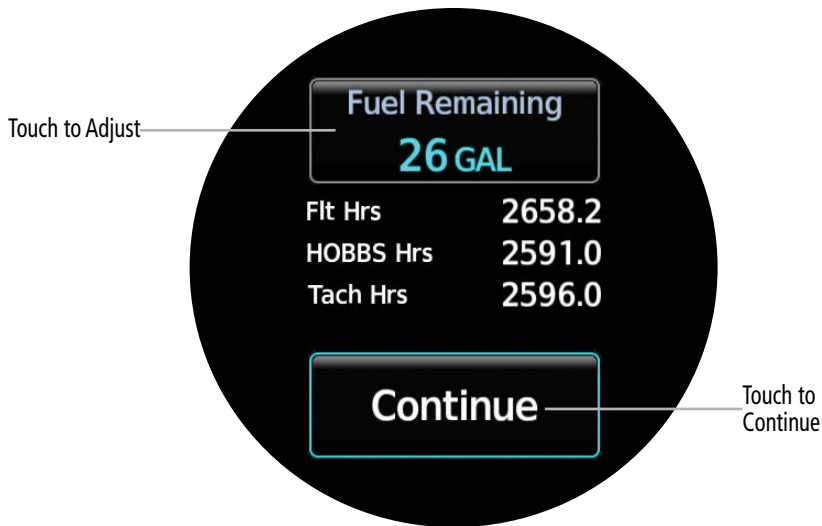

Estimated Fuel on Start-up

If Auxiliary (AUX) fuel tanks are installed and properly configured, the Fuel Options Menu will allow the user display 'AUX' and a 'L' for the Left Auxiliary Fuel Tank, or a 'R' for the Right Auxiliary Fuel Tank (gals).

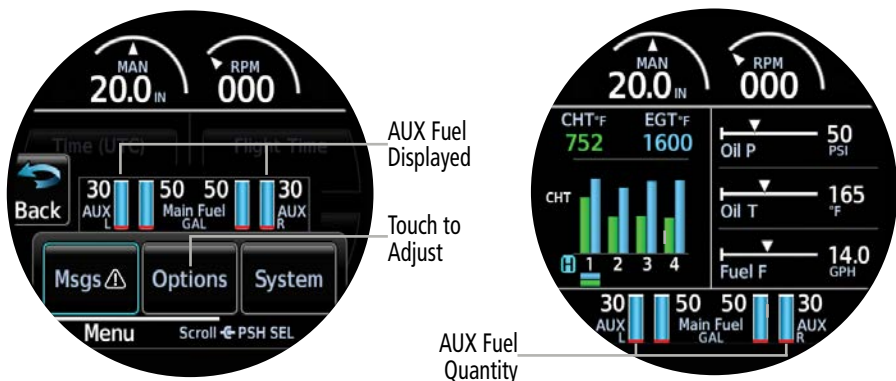

If an external navigator is configured, the 'Fuel' Page will also display fuel calculations based on flight plan information.

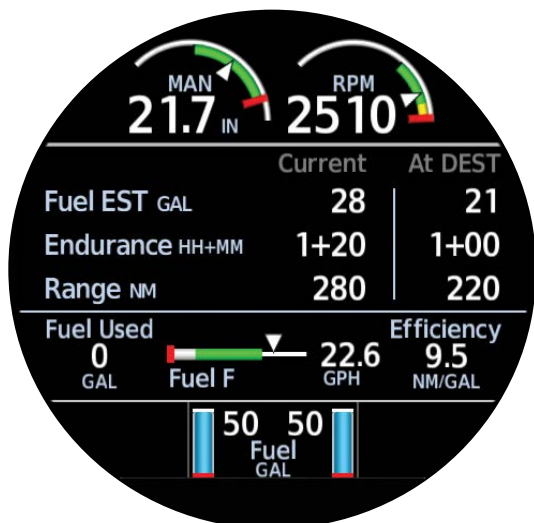

Fuel Page - Summary

Fuel Flow Calibration

The Fuel Flow Calibration feature compares the estimated fuel used calculation to the actual fuel used (input by the pilot upon refueling) and a calibration adjustment is displayed as a percentage. This adjustment can then be applied to future fuel flow calculations.

Entering Estimated Fuel Remaining:

- 1) From the 'Fuel' Page, open the page menu and select **Options**.
- 2) Ensure the **Fuel EST** Button is selected (cyan highlight). Then, use the Small Knob to adjust the estimated fuel remaining.

Recalibrating fuel flow calculations:

- 1) From the 'Fuel' Page, open the page menu and select **Options**.
- 2) Select the **FFLOW Cal** Button. A scrolling menu for fuel flow calibration is displayed. Swipe left or right to view all fuel flow calibration buttons.
- 3) Select the **Act Used** Button. Use the Small Knob to enter the actual fuel used and select the **Enter** Button.
- 4) The estimated fuel used value is compared to the actual fuel used input and a calibration adjustment is displayed. Select the **Recalibrate** Button.
- 5) Touch the **Confirm** Button to confirm and apply this adjustment to future fuel flow calculations. To cancel, select the Back Button and return to the fuel flow calibration menu.

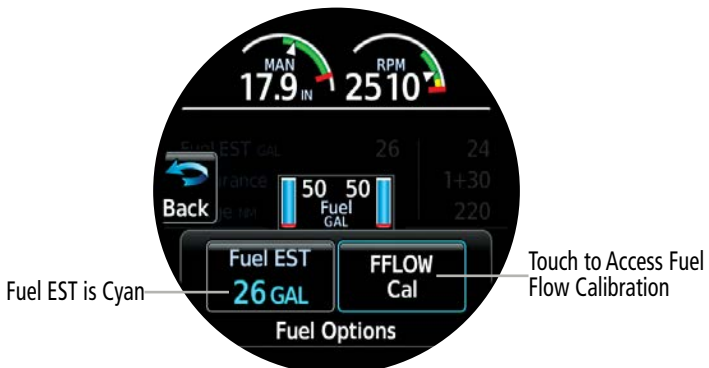

Fuel Options

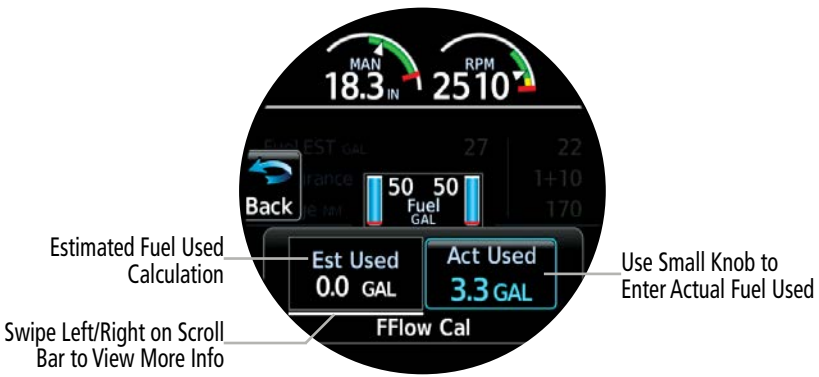

Actual Fuel Used



Fuel Flow Calibration

Recalibrating Fuel Flow Calculations

3.4 ABNORMAL OPERATIONS

EIS ALERTS



NOTE: Refer to the current aircraft flight manual for alert corrective procedures.





NOTE: Alert indications depend on the current configuration and may vary from the examples discussed in this section.



NOTE: When configured as an MFD or Standby ADI, annunciations will display but will not flash, and cannot be acknowledged.

Yellow and red indications on gauges represent caution and warning limitations, respectively. Exceedance of any caution or warning limitation triggers an alert, and a flashing annunciation is displayed at the top left of the page. The associated gauge, indicator, or text may also flash or change color.

Alerting levels are defined below in order of priority:

- **Warning:**  This level of alert requires immediate pilot attention. A warning alert is annunciated in red text and depending on the alert, may be accompanied by an aural alert.
- **Caution:**  This level of alert indicates the existence of abnormal conditions on the aircraft that may require pilot intervention. A caution alert is annunciated in yellow text and may be accompanied by an aural alert.

Advisory:  This level of alert provides general information to the pilot. A message advisory alert is annunciated in white text.

The annunciation indicator can be displayed at the top left of any EIS page. An annunciation will continue to flash until it is acknowledged. To acknowledge an alert, press the Small Knob or touch the flashing annunciation. If all gauges in exceedance are in view on the current EIS page, touching the flashing annunciation (or pushing the Small Knob) will immediately acknowledge the alert. If any gauge in exceedance is not in view, touching the flashing annunciation (or pushing the Small Knob) automatically displays the 'Main' Page so the alerting condition may be quickly reviewed. If the alert occurs on a page where the gauge exceedance can be viewed, the system will not navigate to the main gauge page. As an example, while on the CHT/EGTj page, an exceedance occurs on a CHT, the system will allow the alert to be acknowledged and remain on the CHT/EGT page unless there are multiple alerts, in which case the system will navigate to the main gauge page.

As an alternate method of acknowledgment, certain gauges can be touched to acknowledge the specific alert. The CHT/EGT graph on the 'Main' Page can be touched to automatically switch to the CHT/EGT Page and acknowledge a CHT, Primary EGT, or TIT alert only. The Fuel Quantity gauge can also be touched on any EIS page to automatically switch to the Fuel Page and acknowledge a fuel flow or fuel quantity alert only.

Once an alert has been acknowledged, the annunciation will stop flashing. The associated gauge, indicator, or text may continue to flash for an additional five seconds to aid in identification after automatically changing pages. However, the annunciation (and cautionary/warning indications) continues to display until normal operating conditions are restored.

When multiple alerts are issued, a Warning alert has a higher priority over a Caution alert and will display a Red Warning triangle first.

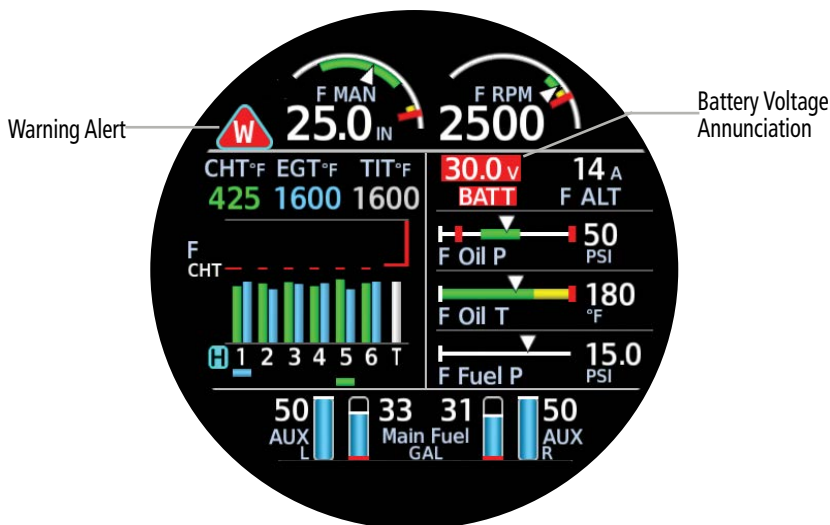

EIS Alerts - Warning - Battery Voltage



EIS Alerts - Caution - Oil Temperature

SECTION 4 NAVIGATION

4.1 INTRODUCTION



WARNING: Always refer to current aeronautical charts and NOTAMs for verification of displayed aeronautical information. Displayed aeronautical data may not incorporate the latest NOTAM information.



WARNING: Do not use Basemap information (land and water data) as the sole means of navigation. Basemap data is intended only to supplement other approved navigation data sources and should be considered only an aid to enhance situational awareness.

The 'HSI Map' Page is available for navigation when the MFI is configured as a Standby ADI, Standby HSI, Primary HSI, or as an MFD. Both the 'HSI Map' Page and the 'Map' Page are available for navigation when the MFI is configured as a Standby ADI or MFD. Both the 'HSI Map' Page and the 'Map' Page display aviation data (e.g., airports, VORs, airways, airspace), geographic data (e.g., cities, lakes, highways, borders), and topographic data (map shading indicating elevation). See the Map Data discussion in this section for more information.

Along with map data, the 'HSI Map' Page and the 'Map' Page display aircraft position, Direct To navigation, and flight plan data. See the Direct-to and Flight Plan Navigation discussion in this section for more information.

The MFI is equipped with an internal GPS, though it may only be used for VFR navigation purposes. If available, an external GPS will be used rather than the internal VFR GPS. The VFR GPS will only be available for use if either of the following conditions are met:

- No external GPS is configured
- External GPS data is lost

GPS navigation is discussed in the Direct-to and Flight Plan Navigation discussion in this section; information concerning loss of GPS is discussed in the Abnormal Operations portion of this section.

4.2 MAP DATA

This portion of the Navigation section will provide an overview of the different kinds of map symbols and overlays which can be displayed, along with map range and detail information. Setup information is covered separately for the Primary HSI and the MFD.

MAP RANGE

The current range setting is indicated on the Range Button. The range setting may be changed by zooming in and out. To change the map range, turn the Small Knob counter-clockwise or touch and pinch fingers together to zoom out and increase the range. Turn the Small Knob clockwise or touch and spread fingers apart to zoom in and decrease the range.

Range Ring

The range setting corresponds with the distance from the ownship icon to the edge of the Range Ring. The Range Ring will be displayed when navigating to any map page, and anytime adjustments to the range are made. The Range Ring will initially be displayed when a navigation map is first displayed, and when adjusting the range, then the ring will fade. If desired, the Range Ring may be enabled for always-on display.

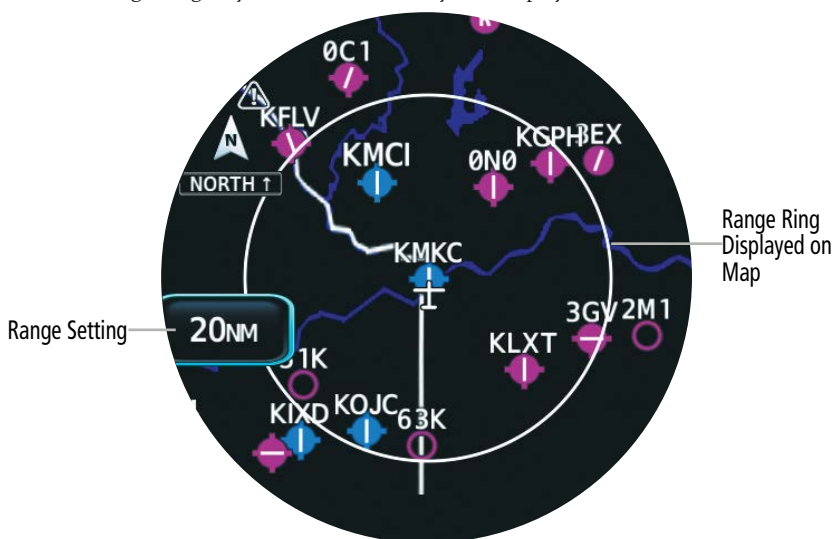

'Map' Page - Range Ring

Enabling/disabling the always-on setting for the range ring (Primary HSI):

- 1) From the 'HSI Map' Page, open the menu and select **Options > Map Options**.
- 2) Select the **Range Ring** Button to enable/disable this setting.

Enabling/disabling the always-on setting for the range ring (Standby ADI / MFD):

- 1) From the 'HSI Map' Page, open the menu and select **HSI Map Options > Map Options**.

Or:

From the 'Map' Page, open the menu and select **Map Options > Map Options**.











- 2) Select the **Range Ring** Button to enable/disable this setting.

MAP SYMBOLS

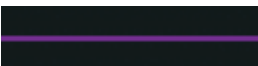
The following tables describe the various symbols which may be displayed. The amount of symbols displayed on the map at one time depends on the range and detail level.

| Land Symbol Name | Symbol |
|-----------------------------------|--------|
| User Waypoint | |
| Highways and Roads | |
| - Interstate Highway (Freeway) | |
| - International Highway (Freeway) | |
| - US Highway (National Highway) | |
| - State Highway (Local Highway) | |
| - Local Road (Local Road) | N/A |
| Railroad | |
| Large City (> 200,000) | |
| Medium City (> 50,000) | |
| Small City (> 5,000) | |
| State/Province | |
| River/Lake | |
| Latitude/Longitude (LAT/LON) | |

Aviation Symbols

| Item | Symbol |
|--|---|
| Temporary Flight Restriction (TFR) |  |
| Class B Airspace Altitude Label (ceiling/floor) |  |
| Class C Airspace Altitude Label (ceiling/floor) |  |
| Class D Airspace Altitude Label (ceiling) |  |
| Class B/Terminal Maneuvering Area and surrounding airways (CL B/TMA/AWY) |  |
| Class C Airspace/Control Area (CL C/CTA) |  |
| Class D Airspace/ Class A Airspace (CL A/D) |  |
| Restricted and Prohibited Areas (Restricted) |  |
| Military Operations Areas (MOA (Military)) |  |
| - ADIZ |  |
| - Alert |  |
| - Danger/Warning |  |

System Overview

Flight Instruments

EIS

Navigation

Hazard Avoidance

Autopilot

WSI

Additional Features

Appendices

Index

| | |
|--|----------------------------------|
| Large Airport (Longest Runway \geq 8100 ft) | |
| Medium Airport (8100 ft > Longest Runway \geq 5000 ft, or Longest Runway < 5000 ft with control tower) | |
| Small Airport (Longest Runway < 5000 ft without a control tower) | |
| Private (Restricted) Airport | |
| Heliport | |
| VOR | |
| VOR Compass Rose On/Off | |
| Non-directional Beacon (NDB) | |
| Intersections | |
| Visual Reporting Point (VRP) | |
| SafeTaxi | (see Additional Feature Section) |
| Runway Extensions | |

Miscellaneous Symbols

| Item | Symbol |
|--|--------|
| Map Pointer Crosshair (when panning) | |
| User Waypoint | |
| Along Track Waypoint | |
| Displayed when aircraft GPS location is valid, but heading is invalid, and aircraft is stationary. | |
| Top of Descent (TOD) | |
| Bottom of Descent (BOD) | |

MAP DETAIL

The map detail setting changes allows the pilot to progressively step through four levels of detail that can be displayed on the navigation map. Decreasing the Map Detail Level decreases how many map items are displayed.

| Item | Detail Level | | | |
|----------------|--------------|---|---|--------------|
| | 4 (Most) | 3 | 2 | 1 (Least) |
| Small Cities | * | | | |
| Medium Cities | * | | | |
| Large Cities | * | | | |
| Freeways | * | | | |
| Highways | * | | | |
| Roads | * | | | |
| Railroads | * | | | |
| Basemap Labels | * | | | |

| | | | | |
|---|---|---|---|--|
| VORs | * | * | | |
| NDBs | * | * | | |
| User Waypoints | * | * | | |
| Line Obstacles | * | * | | |
| Point Obstacles | * | * | | |
| Airspaces that are not prohibited or restricted | * | * | | |
| SafeTaxi | * | * | * | |
| Prohibited Airspaces | * | * | * | |

* Item is displayed on the map for this Map Detail Level.

Detail Levels for Decluttering

Changing the map detail setting (Primary HSI):

- 1) From the 'HSI Map' Page, open the menu and select **Options > Map Options**.
- 2) Select the **Map Detail** Button. Select the button again, as necessary, to cycle through each level of detail and choose the desired setting.

Changing the map detail setting (Standby ADI / MFD):

- 1) From the 'HSI Map' Page, open the menu and select **HSI Map Options > Map Options > Map Detail**.
Or:
 From the 'Map' Page, open the menu and select **Map Options > Map Detail**.
- 2) Select and slide the map detail slider to adjust up or down to change the map detail setting.

MAP OPTIONS - PRIMARY HSI

When the MFI is configured as a Primary HSI, both the 'HSI' Page and 'HSI Map' Page are available. Map options for the 'HSI Map' Page are discussed as follows. Course and Heading controls using either the 'HSI' Page or the 'HSI Map' Page are discussed in the Flight Instruments Section.

Cities, Rivers and Lakes, Roads, State Borders, Intersections, NDBs, VORs, and VRPs are always displayed on the 'HSI Map' Page depending on map range and detail level. If configured, SafeTaxi information will also be displayed depending on map range and detail level.



NOTE: Some map options may or may not be available depending on what external source is available to provide the necessary data

Airspace

Display settings for airspace on the 'HSI Map' Page may be set to 'Off' to remove airspace from being shown on the navigation map, or 'All' to display all airspace. Airspace may also be displayed based on its vertical boundaries by choosing to only show airspace below a certain altitude. For example, if 'Below 3000FT' is selected, only airspace below 3000 feet will be depicted on the map. This may result in only some rings of the Class B or Class C airspace being displayed if no portion of that ring extends below 3000 feet.



Airspaces - 'HSI Map' Page

Changing the airspace display settings:

- 1) From the 'HSI Map' Page, open the menu and select **Options > Map Options**.
- 2) Select the **Airspaces** Button. Select the button again, as necessary, to cycle through each option and choose the desired setting.

Airways

Airways may be displayed on the map at the pilot's discretion. When airways are selected for display on the 'HSI' Map, the airway waypoints (VORs, NDBs, and Intersections) are also displayed.

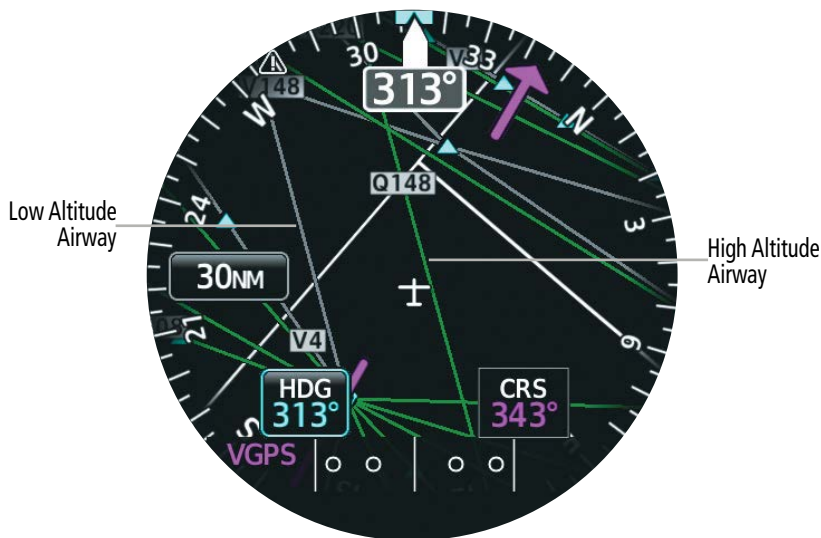

Airways - 'HSI Map' Page

Enabling/disabling the display of airways:

- 1) From the 'HSI Map' Page, open the menu and select **Options > Map Options**.
- 2) Select the **Airways** Button. Select the button again, as necessary, to cycle through each option and choose the desired setting.

AutoZoom

The AutoZoom function automatically changes the map range when a transition between air and ground state occurs.



NOTE: Adjusting/changing AutoZoom is only present on the Map page, when a Map page is configured.

Enabling/disabling AutoZoom:

- 1) From the 'Map' Page, open the menu and select **Options > Map Options > Map Options**.
- 2) Select the **AutoZoom** Button to enable/disable the function.

Obstacles and Wire

The 'HSI Map' Page can display obstacle and wire data. The color of the obstacles shown depend on the aircraft altitude. For more information, see the Hazard Avoidance Section.

Enabling/disabling the display of obstacles and wires on the 'HSI Map' Page:

- 1) From the 'HSI Map' Page, open the menu and select **HSI Map Options > Map Options**.
- 2) Select the **OBST/Wire** Button to enable/disable the display of obstacles and wires.

Terrain

The 'HSI Map' Page can display relative terrain data. Terrain overlay colors on the navigation map depend on the aircraft altitude. For more information on terrain, see the Hazard Avoidance Section.



Terrain Alert - 'HSI Map' Page

Enabling/disabling the display of relative terrain:

- 1) From the 'HSI Map' Page, open the menu and select **Options > Map Options**.
- 2) Select the **Terrain** Button to enable/disable the display of relative terrain on the map.

Topographical data (TOPO)

The 'HSI Map' Page can display topographical data by showing various shades of colors representing land elevation, similar to aviation sectional charts. Topographical data can be displayed or removed as described in the following procedures.

Enabling/disabling the display of topographical data:

- 1) From the 'HSI Map' Page, open the menu and select **Options > Map Options**.
- 2) Select the **Topo** Button to enable/disable the display of topographical data on the map.

Track Vector

The 'HSI Map' Page and the 'Map' Page can display a track vector that is useful in minimizing track angle error. The track vector is a dashed cyan line segment extended to a predicted location. The track vector look-ahead time is selectable (30 sec, 60 sec (default), 2 min, 5 min, 10 min, 20 min) and determines the length of the track vector.

Changing the track vector display settings:

- 1) From the 'HSI Map' Page, open the menu and select **Options > Map Options > Map Options > Track Vector**.
- 2) Select the **Track Vector** Button. Select the button again, as necessary, to cycle through each option and choose the desired setting.

Traffic

The 'HSI Map' Page can display traffic information. Traffic may or may not be shown depending on the other aircraft's location and equipment. For more information on traffic and traffic options, see the Hazard Avoidance Section.

Enabling/disabling the display of traffic:

- 1) From the 'HSI Map' Page, open the menu and select **Options > Map Options**.
- 2) Select the **Traffic** Button to enable/disable the display of traffic on the map.

Weather Legend

A legend for weather products is available. The legend will display information for each weather option that is enabled and displayed on the map. For more information on how to display weather products on the map, see the following Weather Options discussion.

Viewing the Weather Legend:

- 1) From the 'HSI Map' Page, open the menu and select **Options > Map Options**.
- 2) Select the **Weather Legend** Button to view the legend.

Weather Options

The 'HSI Map' Page can display Stormscope lightning and various types of datalink weather information. Weather options may or may not be available depending on the configured equipment and subscription status, if applicable. For more information on Stormscope and datalink weather, see the Hazard Avoidance Section.

STORMSCOPE LIGHTNING

Stormscope lightning data may be overlaid on the navigation map. See the Hazard Avoidance section for more information on lightning data.

Enabling/disabling the display of Stormscope lightning data:

- 1) From the 'HSI Map' Page, open the menu and select **Options > Map Options > Weather Opts.**
- 2) Select the **STRMSCP** Button to enable/disable the display of lightning data on the HSI map.
- 3) Select the **STRMSCP Mode** Button as desired to toggle between Cell Mode or Strike Mode.

DATALINK WEATHER SOURCE

SiriusXM and FIS-B weather options may be available for display on the map.

Selecting the datalink weather source:

- 1) From the 'HSI Map' Page, open the menu and select **Options > Map Options > Weather Opts.**
- 2) Select the **Datalink Weather** Button to toggle between SiriusXM or FIS-B.

NEXRAD

The NEXRAD weather option will display NEXRAD precipitation data on the map. See the Hazard Avoidance section for more information on NEXRAD data.

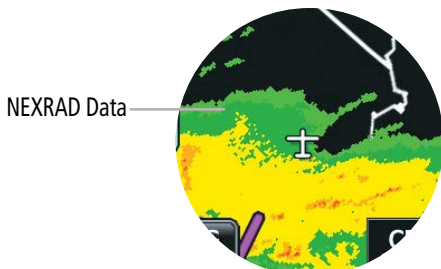

'HSI Map' Page - NEXRAD

Enabling/disabling the display of NEXRAD:

- 1) From the 'HSI Map' Page, open the menu and select **Options > Map Options > Weather Opts.**
- 2) Select the **NEXRAD** Button to enable/disable the display of traffic on the map.

Selecting the NEXRAD Source (SiriusXM only):

- 1) From the 'HSI Map' Page, open the menu and select **Options > Map Options > Weather Opts.**
- 2) Select the **NEXRAD Source** Button to toggle between COMP (Composite) or Base radar.

MAP OPTIONS - STANDBY ADI / MFD

When the MFI is configured as a Standby ADI or an MFD, both the 'HSI Map' Page and 'Map' Page are available. This section will discuss the map options available for the 'HSI Map' Page and the 'Map' Page.



NOTE: Some map options may or may not be available depending on what external source is available to provide the necessary data.

Airports

Airports/heliports are always displayed on the 'HSI Map' Page depending on map range and detail level. Airports/heliports may be displayed on the 'Map' Page at the pilot's discretion, by changing the display settings for private, small, medium, and large airports.

Enabling/disabling the display of Airports on the 'Map' Page:

- 1) From the 'Map' Page, open the menu and select **Map Options > Aviation Options**.
- 2) Select the **Airports** Button to enable/disable the display of airports.

Changing display settings for each airport type on the 'Map' Page:

- 1) From the 'Map' Page, open the menu and select **Map Options > Aviation Options > Airport Options**.
- 2) Select the desired Airport Type Button to enable/disable the display of that type of airport.
- 3) If necessary, select the desired Airport Range Button to display a list of range display settings. Select the desired range display setting for that airport type.
- 4) Repeat Steps 2 and 3 as necessary for each airport type.

Enabling/disabling the display of Heliports on the 'Map' Page:

- 1) From the 'Map' Page, open the menu and select **Map Options > Map Options > Aviation Options**.
- 2) Select the **Heliports** Button to enable/disable the display of heliports.
- 3) If necessary, select the **Heliports RNG** Button to display a list of range display settings. Select the desired range display setting.

Airspace

The following types of airspaces can be displayed: Class B/TMA, Class C/TCA, Class D, Restricted/Prohibited, MOA (Military), Air Defense Identification Zone (ADIZ), and other airspace provided by the navigation database.

More information on panning the map and reviewing each airspace displayed is discussed later in this section.

AIRSPACE ON THE 'HSI MAP' PAGE

Display settings for airspace on the 'HSI Map' Page may be set to 'Off' to remove airspace from being shown on the navigation map, or 'All' to display all airspace. Airspace may also be displayed based on its vertical boundaries by choosing to only show airspace below a certain altitude. For example, if 'Below 3000FT' is selected, only airspace below 3000 feet will be depicted on the map. This may result in only some rings of the Class B or Class C airspace being displayed if no portion of that ring extends below 3000 feet.

Changing the 'HSI Map' Page airspace display settings:

- 1) From the 'HSI Map' Page, open the menu and select **HSI Map Options > Map Options > Airspaces**.
- 2) The 'Airspaces' Screen is displayed. The option to display no airspace (Off), all airspace (All), or only airspace below a certain altitude is provided. Select the desired Airspace Setting Button.

AIRSPACE ON THE 'MAP' PAGE

Display settings for airspace on the 'Map' Page include the same vertical boundary settings as the 'HSI Map' Page (see previous). Additionally, each kind of airspace may be enabled or disabled independently, and airspace altitude labels may also be enabled/disabled. Lastly, the 'Map' Page also provides the Smart Airspaces function.



Airspaces - 'Map' Page

Changing the 'Map' Page airspace display settings:

- 1) From the 'Map' Page, open the menu and select **Map Options > Aviation Options**.
- 2) Select the **Airspaces** Button to enable/disable the display of airspaces.

Or:

- a) Select the **Airspace Options** Button.
- b) Select the **Show Airspaces** Button. The option to display no airspace (Off), all airspace (All), or only airspace below a certain altitude is provided. Select the desired Airspace Setting Button.

Changing 'Map' Page display settings for each airspace type:

- 1) From the 'Map' Page, open the menu and select **Map Options > Map Options > Aviation Options > Airspace Options**.
- 2) Select the desired Airspace Type Button to enable/disable the display of that airspace.
- 3) If necessary, select the desired Airspace Range Button to display a list of range display settings. Select the desired range display setting for that airspace type.
- 4) Repeat Steps 2 and 3 as necessary for each airspace type.

Airspace altitude labels on the navigation map display airspace maximum and minimum altitudes. Depending on range, the system will determine what airspace labels to display in order to achieve the best display and minimal clutter.

Changing 'Map' Page display settings for airspace altitude labels:

- 1) From the 'Map' Page, open the menu and select **Map Options > Map Options > Aviation Options > Airspace Options**.
- 2) Select the **ALT Labels** Button to enable/disable the display of that airspace.
- 3) If necessary, select the **ALT Labels RNG** Button to display a list of range display settings. Select the desired range setting for when airspace altitude labels should be displayed.

The Smart Airspace function de-emphasizes airspaces on the 'Map' Page depending on the current aircraft altitude. The function does not require the aircraft present position or flight path to enter the lateral boundaries of the airspace. If the current aircraft altitude is within 1500 feet of the vertical boundaries of the airspace, the airspace boundary is shown normally. If the current aircraft altitude is not within 1500 feet of the vertical boundaries of the airspace, the airspace boundary is shown subdued.

- System Overview
- Flight Instruments
- EIS
- Navigation
- Hazard Avoidance
- Autopilot
- WSI
- Additional Features
- Appendices
- Index

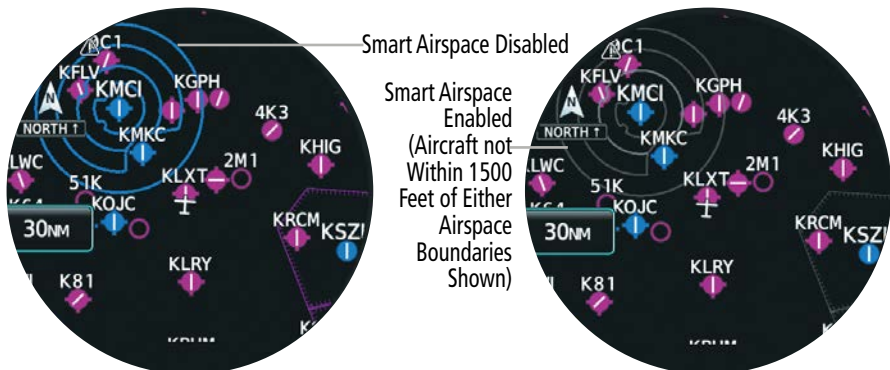

Smart Airspace

Enabling/disabling Smart Airspace on the 'Map' Page:

- 1) From the 'Map' Page, open the menu and select **Map Options > Map Options > Aviation Options > Airspace Options**.
- 2) Select the **Smart Airspaces** Button to enable or disable this function.

Airways

Airways may be displayed on the map at the pilot's discretion. When airways are selected for display, the airway waypoints (VORs, NDBs, and Intersections) are also displayed.

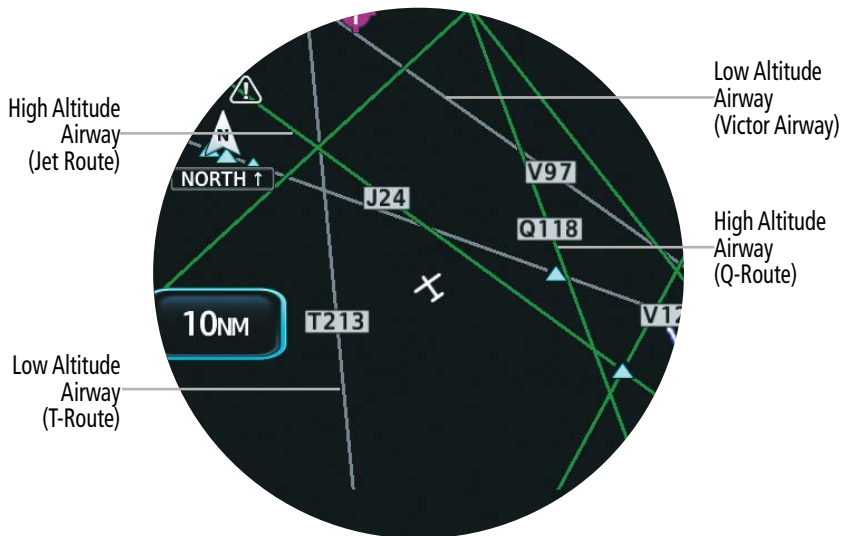

Airways - 'Map' Page

Enabling/disabling the display of airways on the 'HSI Map' Page:

- 1) From the 'HSI Map' Page, open the menu and select **HSI Map Options > Map Options > Airways**.
- 2) Select the **Airways** Button and select the **Off, All, High, or Low** Button to display the desired airways.

Enabling/disabling the display of airways on the 'Map' Page:

- 1) From the 'Map' Page, open the menu and select **Map Options > Aviation Options**.
- 2) Select the **Airways** Button and select the **All, High, or Low** Button to display the desired airways.

Or:

Select the **Low Airways** Button and the **High Airways** Button as necessary to enable/disable the desired airways.

Selecting an airway range for the 'Map' Page:

- 1) From the 'Map' Page, open the menu and select **Map Options > Aviation Options**.
- 2) Select the **Low Airways RNG** Button. Then, select the button for the desired range setting.
- 3) Select the **High Airways RNG** Button. Then, select the button for the desired range setting.

AUTOZOOM ON THE 'MAP' PAGE

AutoZoom adjusts the range on the 'Map' Page when waypoint sequencing occurs for the active flight plan. Control of the ranges at which the auto zoom occurs is done by setting the minimum and maximum 'look forward' times. These settings determine the minimum and maximum range to display based upon the aircraft's ground speed.

Enabling/disabling AutoZoom on the 'Map' Page:

- 1) From the 'Map' Page, open the menu and select **Map Options > Map Options**.
- 2) Select the **AutoZoom** Button to enable/disable the function.

Setting the minimum and maximum range for AutoZoom:

- 1) From the 'Map' Page, open the menu and select **Map Options > Map Options**.
- 2) Select the **AutoZoom Min** Button. Then, select the button for the desired minimum range setting.
- 3) Select the **AutoZoom Max** Button. Then, select the button for the desired maximum range setting.

Cities

Cities are always displayed on the 'HSI Map' Page depending on map range and detail level. Various kinds of cities may be enabled or disabled for display on the 'Map' Page, and the range setting for each kind may be adjusted.

Adjusting the display of cities on the 'Map' Page:

- 1) From the 'Map' Page, open the menu and select **Map Options > Land Options**.
- 2) Select the **Cities** Button to enable/disable the display of cities.
- 3) Select the **City Options** Button.
- 4) Select the button for each desired city type to enable/disable.
- 5) Select the corresponding Range Button for each desired city type. Then, select the desired range setting.

Intersections, NDBs, VORs, and VRPs

Intersections, NDBs, VORs, and VRPs are always displayed on the 'HSI Map' Page depending on map range and detail level. These symbols may be displayed on the 'Map' Page at the pilot's discretion, by changing the display settings for each. The VOR Compass Rose may also be displayed.



VOR, NDB, Intersections Options

System Overview
Flight Instruments
EIS
Navigation
Hazard Avoidance
Autopilot
WSI
Additional Features
Appendices
Index

Enabling/disabling the display of Intersections, NDBs, VORs, and VRPs on the 'Map' Page:

- 1) From the 'Map' Page, open the menu and select **Map Options > Map Options > Aviation Options**.
- 2) Select the corresponding button for the desired item to enable/disable.
- 3) If necessary, select the corresponding Range Button to display a list of range settings. Select the desired range display setting.

LAT/LON Lines

LAT/LON lines may only be displayed on the 'Map' Page.

Enabling/disabling the display of LAT/LON lines on the 'Map' Page:

- 1) From the 'Map' Page, open the menu and select **Map Options > Map Options**.
- 2) Select the **LAT/LON Lines** Button to enable/disable.

Map Orientation

Orientation is not adjustable for the 'HSI Map' Page.

The 'Map' Page can be shown in one of three different orientation options, allowing flexibility in determining aircraft position relative to other items on the map (North Up) or for determining where map items are relative to where the aircraft is going (Track Up), or to the current heading (HDG UP).

North Up (NORTH) aligns the top of the map display to north (default setting).

Track Up (TRK) aligns the top of the map display to the current ground track.

Heading Up (HDG) Up aligns the top of the map display to the current aircraft heading.

Changing the 'Map' Page orientation:

- 1) From the 'Map' Page, open the menu and select **Map Options > Map Options > Orientation**.
- 2) Select the **North Up, Track Up, or Heading Up** Button.

Obstacles and Wires

Obstacles and wires can be displayed. See the Hazard Avoidance section for more information on Obstacles and Wires.



Wires and Obstacles - 'HSI Map' Page

Enabling/disabling the display of obstacles and wires on the 'HSI Map' Page:

- 1) From the 'HSI Map' Page, open the menu and select **HSI Map Options > Map Options**.
- 2) Select the **OBST/Wire** Button to enable/disable the display of obstacles and wires.

Enabling/disabling the display of obstacles on the 'Map' Page:

- 1) From the 'Map' Page, open the menu and select **Map Options > Land Options**.
- 2) Select the **Obstacles** Button to enable/disable the display of obstacles.
- 3) If necessary, select the **Obstacles RNG** Button to display a list of range display settings. Select the desired range setting for when obstacles should be displayed.

Enabling/disabling the display of wires on the 'Map' Page:

- 1) From the 'Map' Page, open the menu and select **Map Options > Land Options**.
- 2) Select the **Wires** Button to enable/disable the display of wires.
- 3) If necessary, select the **Wires RNG** Button to display a list of range display settings. Select the desired range setting for when wires should be displayed.

Railroads

Railroads may only be displayed on the 'Map' Page.

Enabling/disabling the display of railroads on the 'Map' Page:

- 1) From the 'Map' Page, open the menu and select **Map Options > Land Options**.
- 2) Select the **Railroads** Button to enable/disable.
- 3) If necessary, select the **Railroads RNG** Button to display a list of range display settings. Select the desired range setting for when railroads should be displayed.

Rivers/Lakes

Rivers and lakes are always displayed on the 'HSI Map' Page depending on map range and detail level. Rivers and lakes may be enabled or disabled for display on the 'Map' Page, and the range setting may be adjusted.

Enabling/disabling the display of rivers and lakes on the 'Map' Page:

- 1) From the 'Map' Page, open the menu and select **Map Options > Land Options**.
- 2) Select the **Rivers/Lakes** Button to enable/disable.
- 3) If necessary, select the **Rivers/Lakes RNG** Button to display a list of range display settings. Select the desired range setting for when rivers/lakes should be displayed.

Roads

Roads are always displayed on the 'HSI Map' Page depending on map range and detail level. Various kinds of roads may be enabled or disabled for display on the 'Map' Page, and the range setting for each kind may be adjusted.

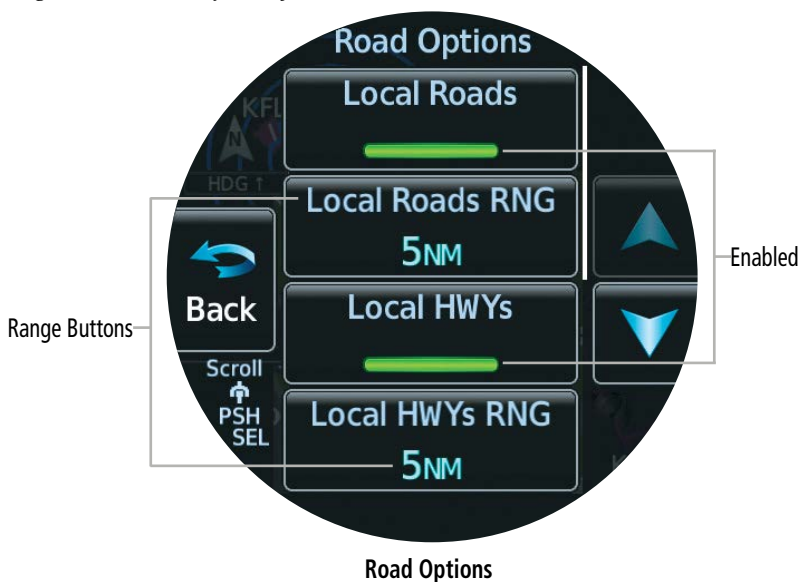

Adjusting the display of roads on the 'Map' Page:

- 1) From the 'Map' Page, open the menu and select **Map Options > Land Options**.
- 2) Select the **Roads** Button to enable/disable the display of roads.
- 3) Select the **Road Options** Button.
- 4) Select the button for each desired road type to enable/disable.
- 5) Select the corresponding Range Button for each desired road type. Then, select the desired range setting.

Runway Extensions

Runway extensions are always displayed on the 'HSI Map' Page depending on map range and detail level. Runway extensions may be displayed on the 'Map' Page at the pilot's discretion, by enabling/disabling and changing the range display settings. Runway Extensions, when enabled, will be depicted under the following conditions:

Flight plan information is displayed and the enroute waypoint after the active leg is an airport.

Flight plan information is displayed with an arrival or approach to the destination airport.

Direct-to navigation to an airport is active.



Runway Extensions

'HSI Map' Page - Runway Extensions

Enabling/disabling the display of runway extensions:

- 1) From the 'Map' Page, open the menu and select **Map Options > Aviation Options**.
- 2) Select the **Runway EXT** Button to enable/disable the display of runway extensions on the map.
- 3) If necessary, select the **Runway EXT RNG** Button to display a list of range settings. Select the desired range display setting.

SafeTaxi

If configured, SafeTaxi information is always displayed on the 'HSI Map' Page depending on map range and detail level. SafeTaxi information may be displayed on the 'Map' Page at the pilot's discretion, by enabling/disabling and changing the range display settings.

See the Additional Features Section for more information on SafeTaxi.

Enabling/disabling the display of SafeTaxi information:

- 1) From the 'Map' Page, open the menu and select **Map Options > Aviation Options**.
- 2) Select the **SafeTaxi** Button to enable/disable the display of SafeTaxi information on the map.
- 3) If necessary, select the **SafeTaxi RNG** Button to display a list of range settings. Select the desired range display setting.

State Borders

State borders are always displayed on the 'HSI Map' Page depending on map range and detail level. State borders may be enabled or disabled for display on the 'Map' Page, and the range setting may be adjusted.

Enabling/disabling the display of state borders on the 'Map' Page:

- 1) From the 'Map' Page, open the menu and select **Map Options > Land Options**.
- 2) Select the **State Borders** Button to enable/disable.
- 3) If necessary, select the **State Borders RNG** Button to display a list of range display settings. Select the desired range setting for when state borders should be displayed.

Track Vector

The 'HSI Map' Page and the 'Map' Page can display a track vector that is useful in minimizing track angle error. The track vector is a dashed cyan line segment extended to a predicted location. The track vector look-ahead time is selectable (30 sec, 60 sec (default), 2 min, 5 min, 10 min, 20 min) and determines the length of the track vector.

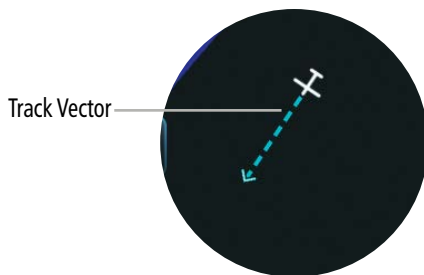

'Map' Page - Track Vector

Changing the track vector display settings for the 'HSI Map' Page:

- 1) From the 'HSI Map' Page, open the menu and select **HSI Map Options > Map Options > Track Vector**.
- 2) Select the desired look-ahead Time Button. To disable the track vector, select the **Off** Button.

Changing the track vector display settings for the 'Map' Page:

- 1) From the 'Map' Page, open the menu and select **Map Options > Map Options > Track Vector**.
- 2) Select the desired look-ahead Time Button. To disable the track vector, select the **Off** Button.

Selected Altitude Intercept Arc

The 'Map' Page can display the location along with current track where the aircraft will intercept the selected altitude. The location will be shown as a cyan arc when the aircraft is climbing or descending.

Enabling/disabling the selected altitude intercept arc:

- 1) From the 'Map' Page, open the menu and select **Map Options > Map Options**.
- 2) Select the **Selected ALT Range Arc** Button to enable/disable.

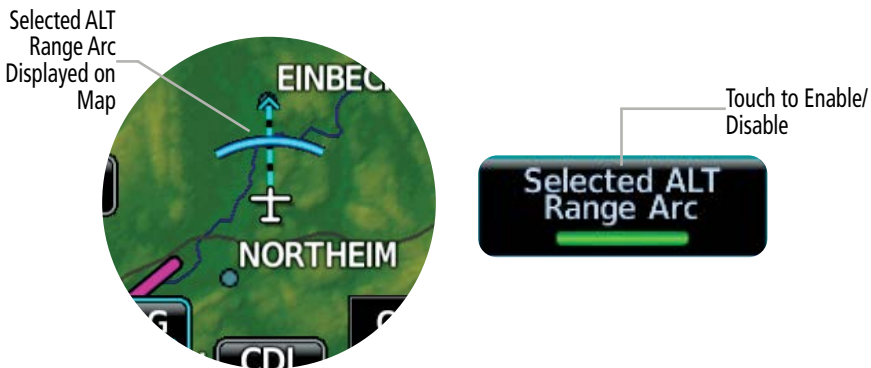

Selected ALT Range Arc Enabled

Topographical Data (Topo)

Topographical data showing various shades of colors representing land elevation can be displayed.

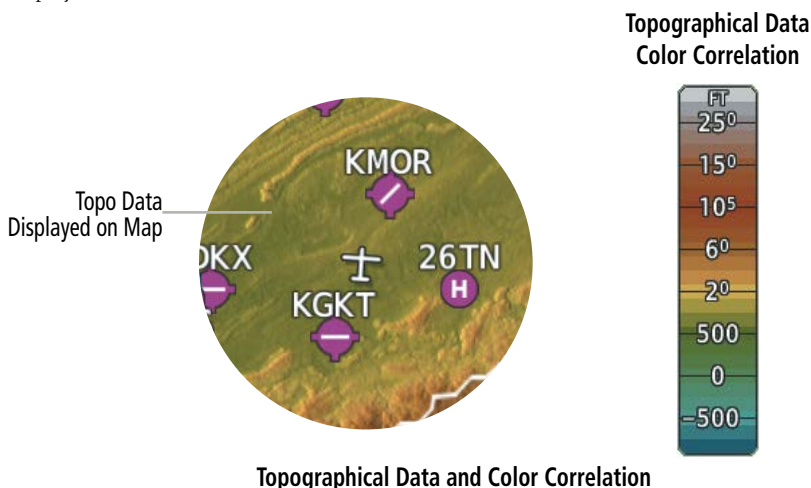

Enabling/disabling the display of topographical data on the 'HSI Map' Page:

- 1) From the 'HSI Map' Page, open the menu and select **HSI Map Options > Map Options**.
- 2) Select the **Topo** Button to enable/disable the display of topographical data from the map.

Enabling/disabling the display of topographical data on the 'Map' Page:

- 1) From the 'Map' Page, open the menu and select **Map Options**.
- 2) Select the **Topo** Button to enable/disable the display of topographical data from the map.

Terrain

Relative terrain data may be displayed which overlays colors on the map depending on the aircraft altitude.

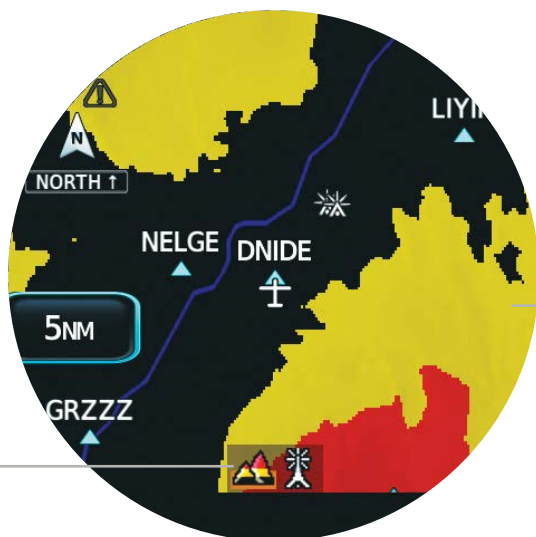

'Map' Page - Terrain and Obstacles

Enabling/disabling the display of relative terrain:

- 1) From the 'HSI Map' Page, open the menu and select **HSI Map Options > Map Options**.

Or:

From the 'Map' Page, open the menu and select **Map Options**.

- 2) Select the **Terrain** Button to enable/disable the display of relative terrain.

Traffic

Traffic may be displayed on the map. Traffic may or may not be available depending on the configured equipment onboard. For more information on traffic data, see the Hazard Avoidance Section.

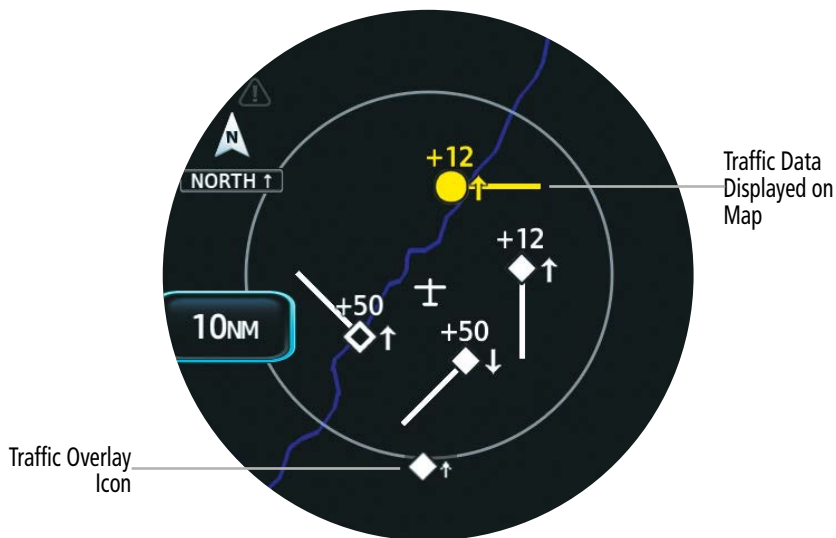

'Map' Page - Traffic

Enabling/disabling the display of traffic for the 'HSI Map' Page:

- 1) From the 'HSI Map' Page, open the menu and select **HSI Map Options > Map Options**.
- 2) Select the **Traffic** Button to enable/disable the display of traffic.

Enabling/disabling the display of traffic for the 'Map' Page:

- 1) From the 'Map' Page, open the menu and select **Map Options**.
- 2) Select the **Traffic** Button to enable/disable the display of traffic.

TFR

Temporary Flight Restrictions (TFRs) may be displayed on the 'Map' Page.

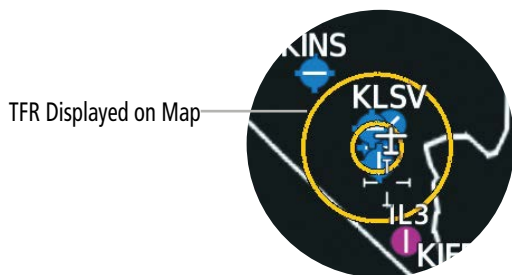

'Map' Page - TFR

Enabling/disabling display of TFRs on the 'Map' Page:

- 1) From the 'Map' Page, open the menu and select **Map Options > Aviation Options**.
- 2) Select the **TFR** Button to enable/disable the display of TFRs on the navigation map.

Weather Legend

A legend for weather products is available. The legend will display information for each weather option that is enabled and displayed on the map. For more information on how to display weather products on the map, see the following Weather Options discussion.

Viewing the Weather Legend for the 'HSI Map' Page:

- 1) From the 'HSI Map' Page, open the menu and select **Options > Map Options**.
- 2) Select the **Weather Legend** Button to view the legend.

Viewing the Weather Legend for the 'Map' Page:

- 1) From the 'Map' Page, open the menu and select **Map Options**.
- 2) Select the **Weather Legend** Button to view the legend.

Weather Options

The 'HSI Map' Page and the 'Map' Page can display Stormscope lightning and various types of datalink weather information. Weather options may or may not be available depending on the configured equipment and subscription status, if applicable. For more information on Stormscope and datalink weather, see the Hazard Avoidance Section.

DATALINK WEATHER SOURCE

SiriusXM and FIS-B weather options may be available for display on the map.

Selecting the datalink weather source for the 'HSI Map' Page:

- 1) From the 'HSI Map' Page, open the menu and select **HSI Map Options > Map Options > Weather Options**.
- 2) Select the **Datalink Weather** Button. Then, select the desired source.

Selecting the datalink weather source for the 'Map' Page:

- 1) From the 'Map' Page, open the menu and select **Map Options > Weather Options**.
- 2) Select the **Datalink WX** Button. Then, select the desired source.

LIGHTNING (SIRIUS XM)

When SiriusXM is the selected datalink weather source, an option to enable the display of lightning is available.

Enabling/disabling the display of SiriusXM Lightning on the 'HSI Map' Page:

- 1) From the 'HSI Map' Page, open the menu and select **HSI Map Options > Map Options > Weather Opts**.
- 2) Select the **Lightning** Button to enable/disable the display of lightning on the map.

Enabling/disabling the display of SiriusXM Lightning on the 'Map' Page:

- 1) From the 'Map' Page, open the menu and select **Map Options > Weather Opts**.
- 2) Select the **Lightning** Button to enable/disable the display of lightning on the map.

METAR

The 'Map Page' can display METAR flags for meteorological conditions at an airport. METAR flags are not available on the 'HSI Map' Page. For more information about weather data and METARs, see the Hazard Avoidance Section.

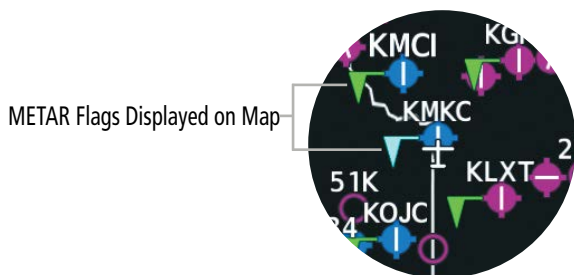

'Map' Page - METAR Flags

Enabling/disabling the display of METAR symbols for the 'Map' Page:

- 1) From the 'Map' Page, open the menu and select **Map Options > Weather Options**.
- 2) Select the **METAR** Button to enable/disable the display of METAR symbols on the navigation map.

NEXRAD

The NEXRAD overlay option will display NEXRAD precipitation data on the map. See the Hazard Avoidance section for more information on weather data.

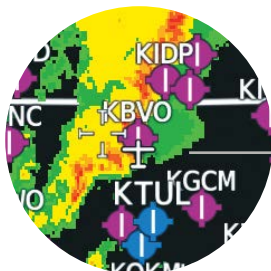

NEXRAD Data Displayed on Map

'Map' Page - NEXRAD

Enabling/disabling the display of NEXRAD for the 'HSI Map' Page:

- 1) From the 'HSI Map' Page, open the menu and select **HSI Map Options > Map Options > Weather Options**.
- 2) Select the **NEXRAD** Button to enable/disable.

Enabling/disabling the display of NEXRAD for the 'Map' Page:

- 1) From the 'Map' Page, open the menu and select **Map Options**.

Or:

From the 'Map' Page, open the menu and select **Map Options > Weather Options**.

- 2) Select the **NEXRAD** Button to enable/disable

Selecting the NEXRAD Source (SiriusXM only) for the 'HSI Map' Page:

- 1) From the 'HSI Map' Page, open the menu and select **HSI Map Options > Map Options > Weather Options**.
- 2) Select the **NEXRAD Source** Button to toggle between Composite or Base radar.

Selecting the NEXRAD Source (SiriusXM only) for the 'Map' Page:

- 1) From the 'Map' Page, open the menu and select **Map Options > Weather Options**.
- 2) Select the **NEXRAD Source** Button to toggle between Composite or Base radar.

STORMSCOPE LIGHTNING



NOTE: Stormscope lightning information cannot be displayed simultaneously on the same map as lightning information from datalink lightning sources.

Stormscope lightning data may be overlaid on the map. See the Hazard Avoidance section for more information on lightning data.

Enabling/disabling the display of Stormscope for the 'HSI Map' Page:

- 1) From the 'HSI Map' Page, open the menu and select **HSI Map Options > Map Options > Weather Options**.
- 2) Select the **Stormscope** Button to enable/disable the display of lightning data on the map.
- 3) Select the **Stormscope Mode** Button as desired to toggle between Cell Mode or Strike Mode.

Enabling/disabling the display of Stormscope for the 'Map' Page:

- 1) From the 'Map' Page, open the menu and select **Map Options > Weather Options**.
- 2) Select the **Stormscope** Button to enable/disable the display of lightning data on the map.
- 3) Select the **Stormscope Mode** Button as desired to toggle between Cell Mode or Strike Mode.

RESTORE DEFAULTS

Map options and settings for the 'Map' Page can be restored either collectively or individually.

Restoring default settings for map options and settings:

- 1) From the 'Map' Page, open the menu and select **Map Options**.
- 2) To restore all map options, select the **Restore Defaults** Button.

Or:

To restore individual map options and settings, select the **Map Options** Button, **Aviation Options** Button, **Land Options** Button, or the **Weather Options** Button. Then, select the **Restore Defaults** Button to restore settings for the selected type. Repeat as necessary.

MAP PANNING

Map panning allows the pilot to:

- View parts of the map outside the displayed range without adjusting the map range
- Highlight and select locations on the map
- Review approximate elevation of the selected map location
- Review bearing and distance to the selected map location
- Review information for a selected airport, NAVAID or user waypoint
- View airspace and airway information



Map Panning - Airport Waypoint

Panning the map:

- 1) From the 'Map' Page, select the map. The crosshair is displayed indicating the map is in the panning mode.
- 2) Touch and drag the map to pan.
- 3) Touch the **Back** Button to exit map panning and re-center the map on the aircraft's current position

Additional Info

More information may be displayed for items on the map by touching the desired map feature. The **Waypoint Info** Button is displayed when any waypoint (airport, NAVAID, user waypoint, etc.) on the map is touched. The **Airspace Info** Button is displayed when the Map Pointer has highlighted an airspace.

If multiple features are present at the selected location, a **Next** Button will appear. Touch the **Next** Button to cycle through each map feature.

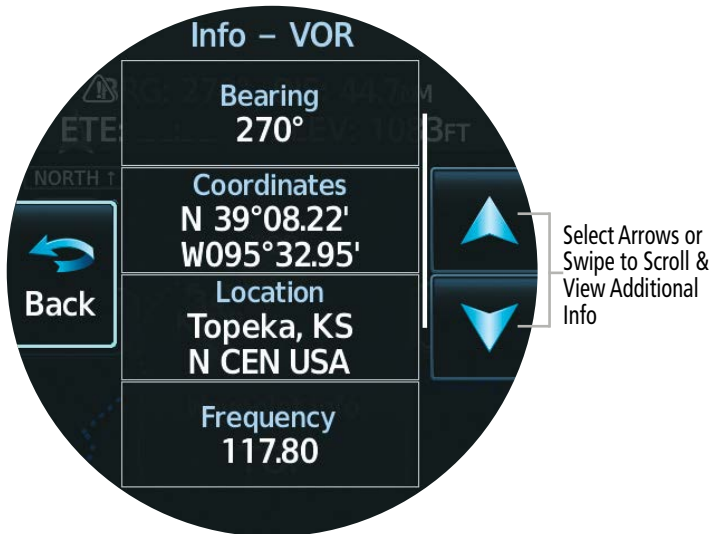

'Info - VOR' Screen

Selecting the **Airspace Info** Button or the **Waypoint Info** Button will display the corresponding information screen. See the following table for a description on each information screen that may be displayed.

| Screen | Information |
|----------------------------------|---|
| Airport 'General Info' Screen | <ul style="list-style-type: none"> Identifier Facility Name Airport Category Distance to airport from aircraft present position Bearing to airport Lat/Lon coordinates Location (city, state/province, country) Elevation Time Zone Fuel services |

- System Overview
- Flight Instruments
- EIS
- Navigation
- Hazard Avoidance
- Autopilot
- WSI
- Additional Features
- Appendices
- Index

| Screen | Information |
|------------------------|--|
| 'Airspace Info' Screen | Name of airspace Class of airspace Status (if applicable) Controlling agency Altitude boundaries |
| 'Info – INT' Screen | Identifier Distance to intersection from aircraft present position Bearing to intersection Lat/Lon coordinates Location (country) Nearest VOR to the intersection (identifier, distance, bearing) |
| 'Info – NDB' Screen | Identifier Distance to NDB from aircraft present position Bearing to NDB Lat/Lon coordinates Location (city, state/province, country) Frequency Nearest airport to NDB (identifier, distance, bearing) Marker Description |
| 'Info – VOR' Screen | Identifier Distance to VOR from aircraft present position Bearing to VOR Lat/Lon coordinates Location (city, state/province, country) Frequency Nearest airport to VOR (identifier, distance, bearing) VOR class Station Declination |

| Screen | Information |
|---------------------|---|
| 'Info – VRP' Screen | Identifier Distance to VRP from aircraft present position Bearing to VFP Lat/Lon coordinates Location (city, state/province, country) Nearest airport to VRP (identifier, distance, bearing) |

Waypoint Information Screens

Reviewing information for a 'Map' Page feature:

- 1) From the 'Map' Page, touch a map feature. If the desired map feature is not within the zoom range, touch the map to activate the panning function, then touch and drag to the location of the map feature and touch the map feature.
- 2) Select the **Waypoint Info** Button or the **Airspace Info** Button to display additional information.
- 3) If the map feature is an airport, select the **General Info** Button to display information about the airport; or select the **Runways** Button to display runway information; or select the **Frequencies** Button to display available frequencies.

4.3 DIRECT TO AND FLIGHT PLAN NAVIGATION



WARNING: Do not use GPS to navigate to any active waypoint identified as a 'NON WGS84 WPT' by a system message. 'NON WGS84 WPT' waypoints are derived from an unknown map reference datum that may be incompatible with the map reference datum used by GPS (known as WGS84) and may be positioned in error as displayed.

DIRECT TO NAVIGATION

This portion of the guide will discuss the Direct To navigation function available on the MFI when either a GTX is configured as a primary GPS source, or when using the internal VFR GPS with no external source. For information concerning loss of GPS, see the Abnormal portion at the end of this Navigation Section.

The Direct To method of navigation allows quick selection of a destination and provides guidance to the selected point. Once a Direct To is activated, a point-to-point course line is created from the present position to the selected Direct To destination. Course guidance is provided until the Direct To is replaced with a new Direct To or until cancelled.

System Overview
Flight Instruments
EIS
Navigation
Hazard Avoidance
Autopilot
WSI
Additional Features
Appendices
Index



Select to Search for Waypoint

Select to Access 'Direct To' Screen



Select Airport

Select to View Nearest Airports List



Waypoint Selection - Direct To

Selecting a Direct To destination using the page menu:

- 1) From any page, open the menu.
- 2) Select the Button. The 'Direct To' Screen is displayed.
- 3) Select the **Waypoint** Button.
- 4) Select the **Recent** Button. A list of previously selected airports is displayed. Select the desired Airport Selection Button.

Or:

Select the **Nearest** Button. A list of airports is displayed in order of distance from aircraft present position. Select the desired Airport Selection Button.

Or:

Select the **Search Waypoint** Button. Enter the waypoint identifier using the keypad and select the **Enter** Button.

Or:

Select the **Search Name** Button. Enter the airport facility name using the keypad and select the **Enter** Button.

Or:

Select the **Search City** Button. Enter the city name using the keypad and select the **Enter** Button.

- 5) Select the **Activate** Button.

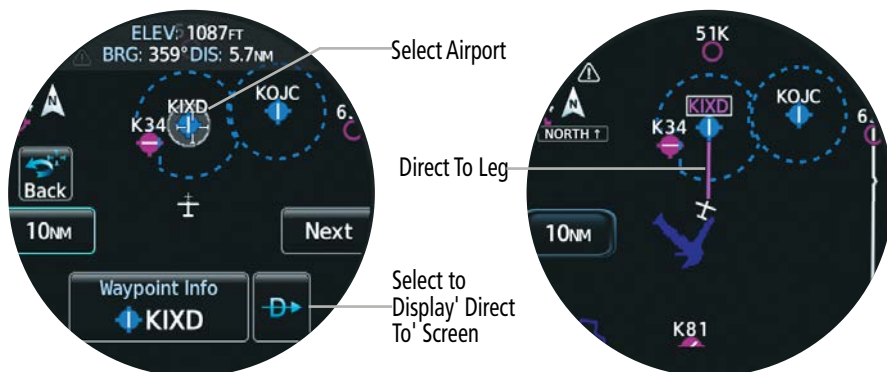

Select Airport - Map - Direct To

Selecting a Direct To destination using the Map Pointer on the 'Map' Page:

- 1) From the 'Map' Page, touch the desired direct to destination on the map. If panning the map is necessary first, touch and drag the map first to activate the panning mode; then, pan the map as needed and touch the desired destination.
- 2) Select the **D➔** Button. The 'Direct To' Screen is displayed showing the selected destination waypoint and course information. If the selected destination is not defined in the navigation database, the system will create a 'MAPWPT'.
- 3) Select the **Activate** Button.

Removing a Direct To destination:

- 1) From any page, open the menu.
- 2) Select the **D➔** Button. The 'Direct To' Screen is displayed.
- 3) Select the **Remove** Button. Direct To navigation is cancelled and the Direct To destination is removed.

Sharing Direct To Navigation from the MFI to Garmin Pilot

Direct To navigation initiated on the MFI may be sent to Garmin Pilot if the mobile device running Garmin Pilot is paired to the MFI. Pairing instructions are discussed in the System Overview Section.



NOTE: Flight plan and Direct To navigation initiated on a mobile device in Garmin Pilot cannot be displayed on the MFI.

Nearest Airport Criteria

Adjusting the Airport Criteria for minimum runway length and surface type controls which airports should be displayed on the Nearest List for Direct To navigation. A minimum runway length and/or surface type can be entered to prevent airports with small runways or runways that are not appropriately surfaced from being displayed.

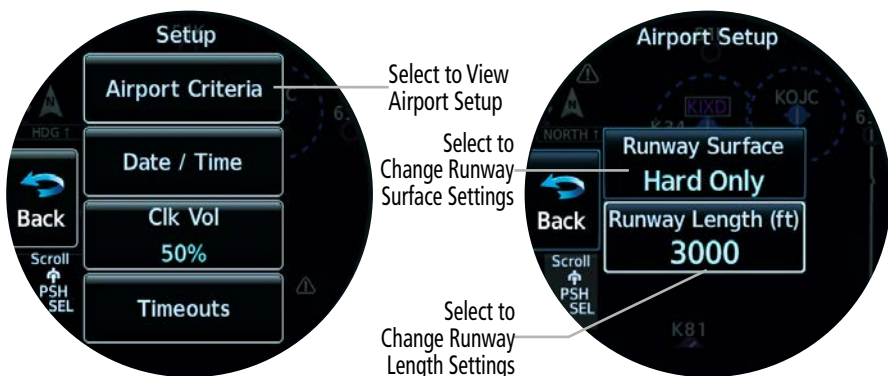

Nearest Airport Settings

Changing the airport criteria for nearest Direct To airports:

- 1) From any page, open the menu. Select **System > Setup > Airport Criteria**.
- 2) Select the **Runway Surface** Button. Then, select the desired Surface Criteria Button.
- 3) Select the **Runway Length** Button. Enter the desired minimum runway length using the keypad and press the **Enter** Button.

FLIGHT PLAN / DIRECT TO NAVIGATION FROM EXTERNAL SOURCE



NOTE: To receive flight plan data, a compatible external source must be configured.

The MFI can be configured to receive flight plan and Direct To navigation from another onboard compatible source, including Integrated Flight Deck systems, Flight Displays, Touch Navigators, and GPS Navigators.

All adjustments to the active flight plan or Direct To leg must be done using the external source. Once adjustments are made, the changes are synced to the MFI. Flight plan legs are displayed on the maps, and flight plan data is displayed on the 'MFD Data' Page.

NAVIGATION DATA DISPLAYED ON MAP

Active flight plan and Direct To navigation data will be displayed on maps using different line widths, colors, and types, based on the type of leg and the segment of the flight plan currently being flown.

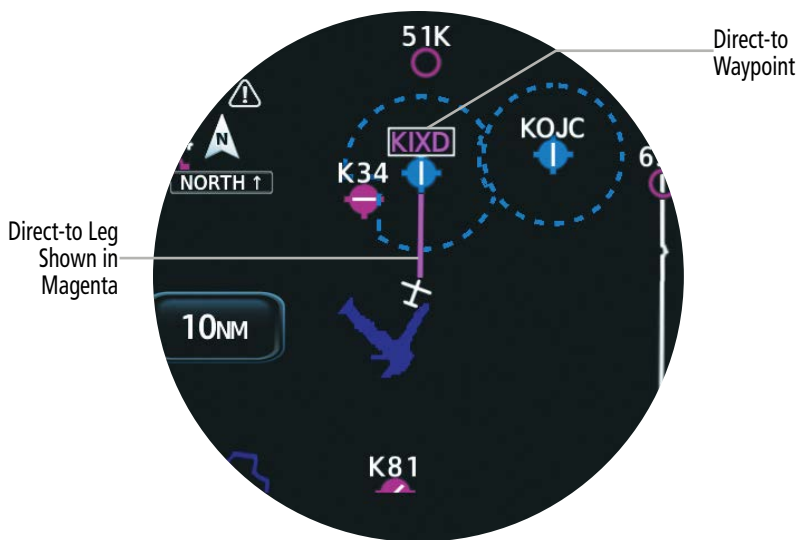

Direct-to Leg - 'Map' Page

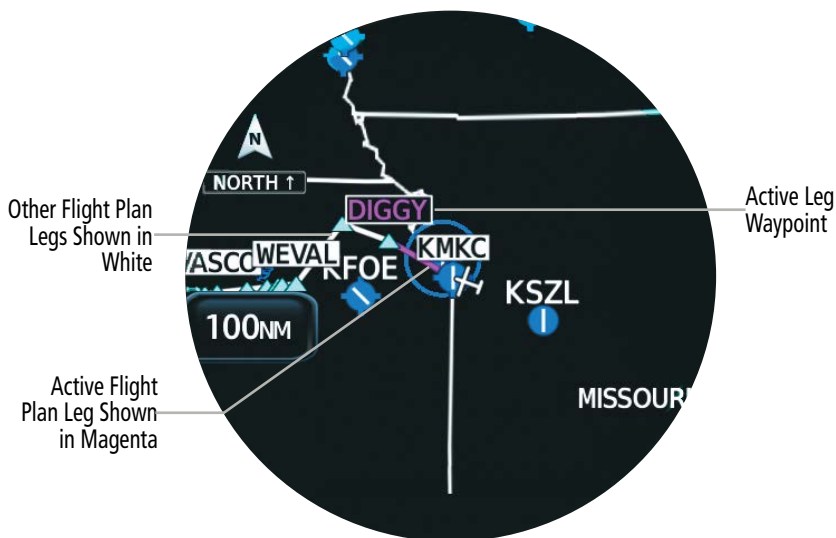

Flight plan - 'Map' Page - Flight Plan Info Received via External Source

| Flight Plan Leg Type | Symbol |
|--|--------|
| Active Course Leg* | |
| Active Heading Leg* | |
| Active Roll Steering Path*† | |
| Course Leg in the current flight segment | |
| Course Leg not in the current flight segment | |
| Heading Leg | |
| Roll Steering Path † | |
| Future Roll Steering Path ‡ | |
| Turn Anticipation Arc | |

* The active leg or path is the one currently being flown and is shown in magenta.

† A Roll Steering Path is displayed for: transitions between two disconnected legs (i.e. holding), some procedure turn segments, parallel track segments, or transitions after some fly-over waypoints (discussed later in this section).

‡ A Roll Steering Path that is beyond the next leg will appear as a Future Roll Steering Path. When a Future Roll Steering Path becomes the next leg, it appears as a Roll Steering Path.

Procedures Loaded in a Flight Plan



NOTE: The system responds to terminal procedures based on data coded within that procedure in the Navigation Database. Differences in system operation may be observed among similar types of procedures due to differences in the Navigation Database coding specific to each procedure.

Departure, arrival, and approach procedure data received from an external source may be displayed on any navigation map. All procedures must be loaded and activated using the external navigator.

For information on changing the navigation source of the CDI, and for information on the display of vertical deviation, see the Flight Instruments Section.

MFD DATA

Navigation data concerning the Direct To leg or active flight plan (flight plan data may only be received from external source) may be viewed on the 'MFD Data' Page. Any of the following may be selected for display on this page:



NOTE: *BRG, DIS, DTK, XTK, and TKE apply to the current active waypoint/leg.*

- Active WPT (Active waypoint)
- BRG (Bearing)
- DIS (Distance)
- DIS to DEST (Distance to Destination)
- DTK (Desired Track)
- ETA (Estimated time of arrival at active fix)
- ETA at DEST (ETA at Destination)
- ETE (Estimated time enroute at active fix)
- ETE to DEST (Estimated time enroute to destination)
- GS (Groundspeed)
- GSL (Geometric Sea Level Altitude)
- MSA (Minimum Safe Altitude)
- OAT (Static) (Outside Air Temperature)
- OAT (Total) (Outside Air Temperature)
- TKE (Track Angle Error)
- TRK (Track)
- Time (Current Time)
- XTK (Cross-track error)
- DALT (Density Altitude)

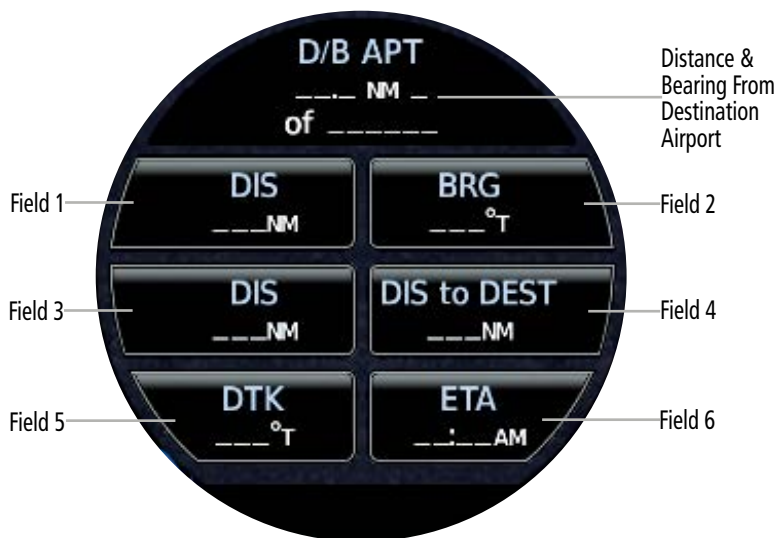

'MFD Data' Page - Flight Plan Info Received via External Source

Changing the information shown in the MFD Data Fields:

- 1) From the 'MFD Data' Page, select the desired Field to modify.
- 2) Select the desired Data Button.
- 3) Repeat Steps 1 and 2 as necessary to change any other data fields.
- 4) After selecting the desired field, the system automatically returns to the MFD page.

FLIGHT PLAN SHARING



NOTE: Flight Plan Sharing is an option only for the GNC 355 / GNX 375 / GPS 175.



NOTE: Flight Plan Transfer from the LRUs to the PED will not include any procedures (i.e. Arrivals, Departures, Approaches).

The Connex feature allows the MFI to serve as an access point for sharing flight plan information from Garmin Pilot to an external navigator. For example, when a mobile device is paired to the MFI, the pilot may create a flight plan in Garmin Pilot and Connex will share the flight plan to another configured, compatible navigator onboard.

Pairing instructions for the MFI are discussed in the System Overview Section of this guide.

See the pertinent flight manual of the external navigator for instructions on enabling the flight plan import function.

4.4 ABNORMAL OPERATIONS

ABNORMAL GPS CONDITIONS

The annunciations in the following table may appear when abnormal GPS conditions occur. GPS navigation will resume automatically once a valid GPS solution is restored.

| Annunciation | Description |
|--------------|--|
| | Loss of Integrity Monitoring. GPS integrity is insufficient for the current phase of flight. |
| | |
| | Loss of GPS Navigation. No GPS Position data is available. |
| | |

Abnormal GPS Annunciations

Up to two external GPS sources may be configured, along with the internal VFR GPS. Each GPS must be configured and operational during the last on-ground start to be available for use. The following table provides information on what GPS source will be used in the event of one or more GPS failure.

| Available GPS Sources | | | GPS Source(s) Used |
|-----------------------|-----------------|------------------|--------------------|
| External GPS #1 | External GPS #2 | Internal VFR GPS | |
| Yes | No | Yes | External GPS #1 |
| No | Yes | Yes | External GPS #2 |
| No | No | Yes | Internal VFR GPS |
| No | No | No | None |

GPS Failure Downgrade

External GPS Failure

If configured, the external GPS shall be considered the Primary GPS, and the internal VFR GPS may be utilized as a Backup GPS. The VFR GPS is continuously being monitored and compared to the Primary GPS, so that a seamless and automatic transition to the VFR GPS will be made if the Primary GPS fails.

If all configured external GPS sources fail, and configured to do so, the MFI will revert to using the internal VFR GPS for emergency Direct To navigation guidance and position data on the moving map. In this case, a system message is generated and Direct To navigation using the internal VFR GPS becomes available. Direct-to navigation is discussed previously in this section. TAWS/terrain and SVT features are not available with the internal VFR GPS.

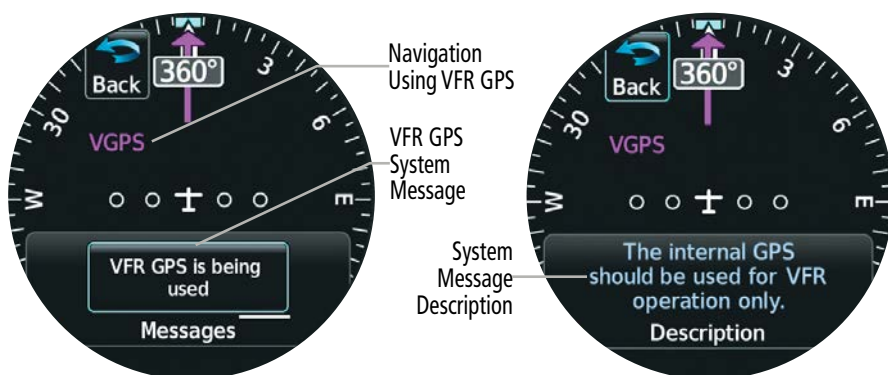

Reversion to VFR GPS - System Message

Complete Loss of GPS

If a complete loss of GPS occurs, the ownship icon is removed and the 'No GPS POS' annunciation will be displayed in yellow on the moving map. TAWS/terrain and SVT features will be lost, and the CDI will be removed.



Complete Loss of GPS - 'No GPS POS' Annunciation - 'HSI Map' Page

System Overview

Flight Instruments

EIS

Navigation

Hazard Avoidance

Autopilot

WSI

Additional Features

Appendices

Index

SECTION 5 HAZARD AVOIDANCE

5.1 INTRODUCTION

Hazard avoidance features are designed to aid situational awareness and provide advisory information regarding potential hazards to flight safety associated with weather, terrain, and air traffic.

- Weather
 - SiriusXM Weather
 - Flight Information Services-Broadcast (FIS-B)
 - Stormscope
- Terrain Avoidance
 - Terrain Proximity
 - Terrain-FLTA / Helicopter Terrain - HFLTA
 - TAWS-B / HTAWS (external TAWS system required)
- Traffic
 - Traffic Information Service (TIS)
 - Traffic Advisory System (TAS) / Traffic Alert and Collision Avoidance System (TCAS)
 - Automatic Dependent Surveillance-Broadcast (ADS-B) Traffic

5.2 DATALINK WEATHER



WARNING: Do not use datalink weather information for maneuvering in, near, or around areas of hazardous weather. Information contained within datalink weather products may not accurately depict current weather conditions.



WARNING: Do not use the indicated datalink weather product age to determine the age of the weather information shown by the datalink weather product. Due to time delays inherent in gathering and processing weather data for datalink transmission, the weather information shown by the datalink weather product may be older than the indicated weather product age.

Datalink weather services, including SiriusXM Weather and Flight Information Services-Broadcast (FIS-B) may be transmitted from a ground station or satellite and received for display on the MFI.

Weather information can be overlaid on various map pages. For more information on weather overlay options on map pages, and which unit configurations offer map pages, see the Map Options discussion in the Navigation Section.

Additionally, dedicated weather pages may be available when configured as a Standby ADI or MFD.

RECEIVING DATALINK WEATHER SERVICES

Datalink weather services may require external datalink equipment to be configured and service activation prior to use. Some services may also require a subscription for services.

SiriusXM Activation and Subscription

Before SiriusXM Weather may be displayed, service must be activated by SiriusXM customer service. An identification code (Data ID Code) specific to the configured datalink receiver must be provided for activation. The Data ID Code may be found on the 'Datalink Status' Page.

Viewing the Data ID Code:

- 1) From the 'SXM WX' Page, open the page menu. Select **SXM WX Options > Datalink Status**.
- 2) The Data ID is displayed at the top of the 'Datalink Status' Page.

Activating SiriusXM Service:

- 1) Contact SiriusXM using the customer service phone number listed on their website.
- 2) Provide SiriusXM customer service the Data ID Code, in addition to payment information, and the desired weather product subscription package to activate service. It may take several minutes for weather products in the selected subscription package to become available.
- 3) To begin activation, position aircraft within satellite reception and open the 'SXM WX' Page menu.
- 4) Select the **SXM WX Options** Button, and then select the **Datalink Status** Button to display the 'Datalink Status' Page.
- 5) The Data ID and radio signal strength is displayed along with the subscription level, software version, and serial number for the external datalink receiver. Weather products provided by the subscription should be listed in green indicating they are available for use. Items listed in gray indicate data is unavailable.

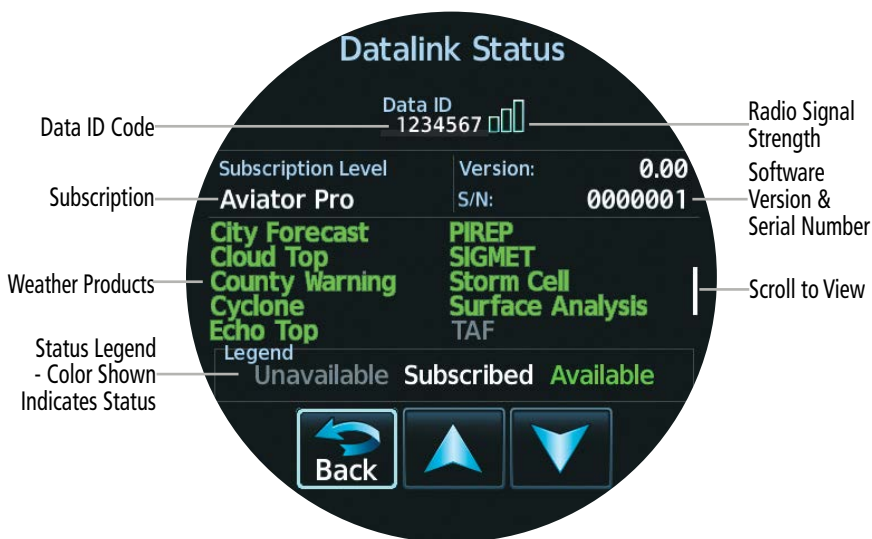

SiriusXM - 'Datalink Status' Page





FIS-B Weather Reception

The FIS-B Weather service, available when equipped with a capable transponder or datalink receiver, receives 978 MHz Universal Access Transceiver (UAT) data and delivers subscription-free weather information periodically and automatically. FIS-B uses a network of FAA-operated Ground-Based Transceivers (GBTs) to transmit information. Reception is limited to line-of-sight and is available below 24,000 feet MSL in the United States. FIS-B transmits weather data in a repeating cycle which may take several minutes to transmit all available weather data. Therefore, not all weather data may be present immediately upon initial FIS-B signal acquisition. FIS-B is a component of the Automatic Dependent Surveillance Broadcast (ADS-B) system, which offers both weather and traffic data; refer to the ADS-B Traffic discussion later in this section for a more detailed discussion of the ADS-B system and its capabilities.

DATALINK WEATHER PRODUCTS

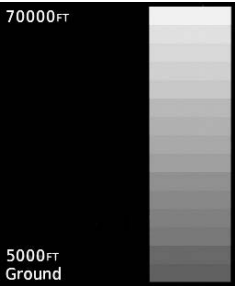
The following table shows each weather product and map symbol. Availability of weather products depend on the datalink equipment and subscription service, if applicable.

| Weather Product | Symbol |
|--|------------------------|
| METARs | |
| TAFs | (N/A) |
| SIGMETs AIRMETs G-AIRMETs | |
| Pilot Weather Report (PIREP) - Urgent - Routine - Route | |
| Winds Aloft - 5 kts - 10 kts - 50 kts | |
| Temporary Flight Restriction (TFR) - SiriusXM - FIS-B - FIS-B Localized | |
| Radar Precipitation (NEXRAD) | |
| | (US) (Regional) |

| Weather Product | Symbol |
|---|---|
| Lightning - SiriusXM - FIS-B Strike - FIS-B Polarity |  |
| Cloud Top |  |
| *Echo Top |  |
| *Cell Movement |  |
| *Freezing Levels |  |
| Icing Potential (SLD and CIP) - SiriusXM - FIS-B - Trace - FIS-B - Light - FIS-B - Moderate - FIS-B - Heavy - FIS-B - SLD |  |

- System Overview
- Flight Instruments
- EIS
- Navigation
- Hazard Avoidance**
- Autopilot
- WSI
- Additional Features
- Appendices
- Index

| Weather Product | Symbol |
|-------------------------------------|--|
| *County Warnings | |
| *Cyclone Warnings | |
| *City Forecast | |
| *Surface Analysis | |
| *Air Report (AIREP) | |
| Turbulence - SiriusXM - FIS-B | <div style="display: flex; flex-direction: column; align-items: center;"> <div style="background-color: black; color: white; padding: 2px;">Extreme</div> <div style="background-color: red; width: 100%; height: 20px; margin: 2px;"></div> <div style="background-color: orange; width: 100%; height: 20px; margin: 2px;"></div> <div style="background-color: yellow; width: 100%; height: 20px; margin: 2px;"></div> <div style="background-color: lightgreen; width: 100%; height: 20px; margin: 2px;"></div> <div style="background-color: purple; width: 100%; height: 20px; margin: 2px;"></div> </div> <div style="display: flex; flex-direction: column; align-items: center; margin-top: 5px;"> <div style="background-color: black; color: white; padding: 2px;">Severe</div> <div style="background-color: black; color: white; padding: 2px;">Light/Mod</div> <div style="background-color: black; color: white; padding: 2px;">No Coverage</div> </div> |

*SiriusXM required

Weather Product Symbols

METARs and TAFs







NOTE: METAR information is only displayed within the installed aviation database service area.

METAR (METeoro logical Aerodrome Report) is an international code used for reporting weather observations. METARs are updated hourly or as needed. METARs typically contain information about the temperature, dew point, wind, precipitation, cloud cover, cloud heights, visibility, and barometric pressure. They can also contain information on precipitation amounts, lightning, and other critical data. If METAR data is available for an airport, a color-coded flag is shown next to the airport.

TAF (Terminal Area Forecast) is the standard format for 24-hour weather forecasts. TAFs may contain some of the same code as METAR data.

Color coded flags indicate the general weather conditions reported by the METAR. The text from a METAR or TAF can be displayed by touching the flag on the weather page, and then selecting the **Info** Button.

| METAR Symbols | |
|---|--|
|  | VFR: Ceiling greater than 3,000 ft. AGL and visibility greater than five miles. |
|  | Marginal VFR: Ceiling 1,000 to 3,000 ft. AGL and/or visibility three to five miles. |
|  | IFR: Ceiling 500 to 1,000 ft. AGL and/or visibility one to three miles. |
|  | Low IFR: Ceiling below 500 ft. AGL and/or visibility less than one mile. |
|  | Unknown |

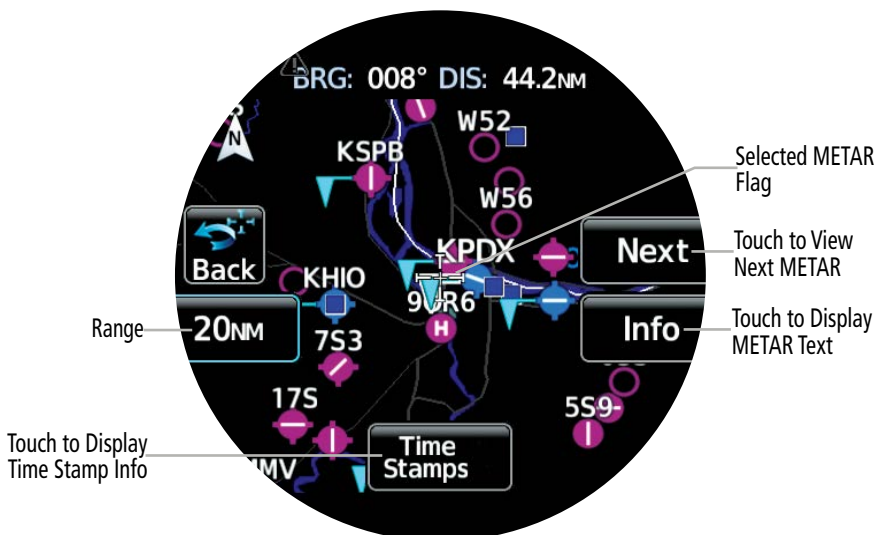

Selected METAR - 'SXM WX' Page

AIRMETS

An AIRMET (AIRmen's METeorological Information) can be especially helpful for pilots of light aircraft that have limited flight capability or instrumentation. An AIRMET must affect or be forecast to affect an area of at least 3,000 square miles at any one time. AIRMETS are routinely issued for six-hour periods and are amended as necessary due to changing weather conditions. AIRMETS are displayed as colored, dashed lines.



AIRMET Legend

| AIRMET Types | |
|----------------------|--|
| Icing | Areas of moderate airframe icing including areal extent |
| Turbulence | Areas of moderate turbulence including vertical extent |
| IFR | Weather conditions with ceilings <1,000 ft and/or visibility <3 mi |
| MTN OBSCR | Widespread mountain obscuration due to clouds, precipitation, smoke, haze, mist, or fog |
| Surface Winds | Sustained surface winds >30 kt and/or potential non-convective wind shear below 2,000 ft AGL |

G-AIRMETS

Graphical AIRMETS (G-AIRMETS) display more weather phenomena than textual AIRMETS, while eliminating the need to interpret raw text. Tapping a G-AIRMET displays textual details. Updates occur 4 times daily.

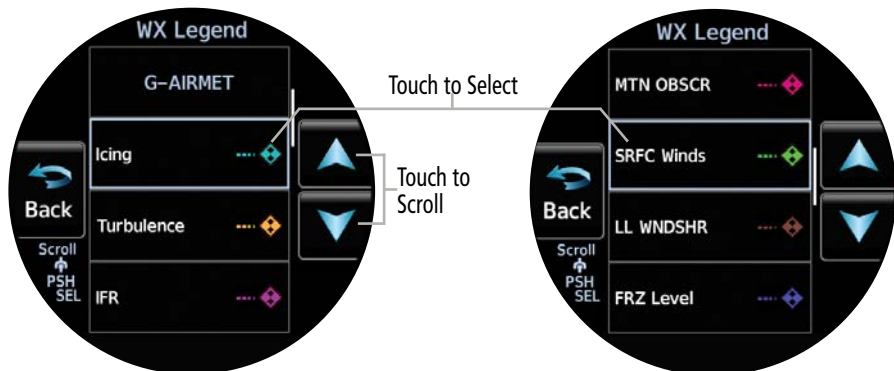

G-AIRMETS

Filtering Options allow the User to mitigate page clutter. Forecast and filter selections are accessible from the FIS-B Weather menu. Forecast periods include 0 (zero) hr, 3 hr, and 6 hr.

| Forecast Settings | |
|-----------------------|--|
| Off | Disables automatic functionality. Filter Options unavailable. |
| Current (Auto) | Displays active graphical records based on the current UTC. Function automatically switches from zero (0) hour to three (3) hr forecasts. |
| All Forecasts | Displays the most recent, non-expired graphical records. |

Center Weather Advisory

These advisories communicate en route and terminal weather conditions expected to occur within the next 2 hours. Information is valid for up to 2 hours.

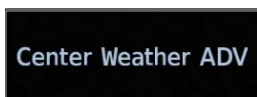

Center Weather Advisory Button

SIGMETs

A SIGMET (SIGNificant METeorological Information) advises of weather that is potentially hazardous to aircraft. In the contiguous United States, the following items are covered: severe icing, severe or extreme turbulence, volcanic ash, dust storms, and sandstorms that lower visibility to less than three statute miles.

A Convective SIGMET is issued for the following conditions: thunderstorms, isolated severe thunderstorms, embedded thunderstorms, hail at the surface, and tornadoes.

A SIGMET is widespread and must affect or be forecast to affect an area of at least 3,000 square miles. SIGMETs are displayed as a yellow-dashed line.



SIGMET

PIREPs

Pilot Weather Reports (PIREPs) provide timely weather information for a particular route of flight. When significant weather conditions are reported or forecast, Air Traffic Control (ATC) facilities are required to solicit PIREPs. A PIREP may contain unforecast adverse weather conditions, such as low in-flight visibility, icing conditions, wind shear, and turbulence. PIREPs are issued as either Routine (UA) (blue) or Urgent (UUA) (yellow).

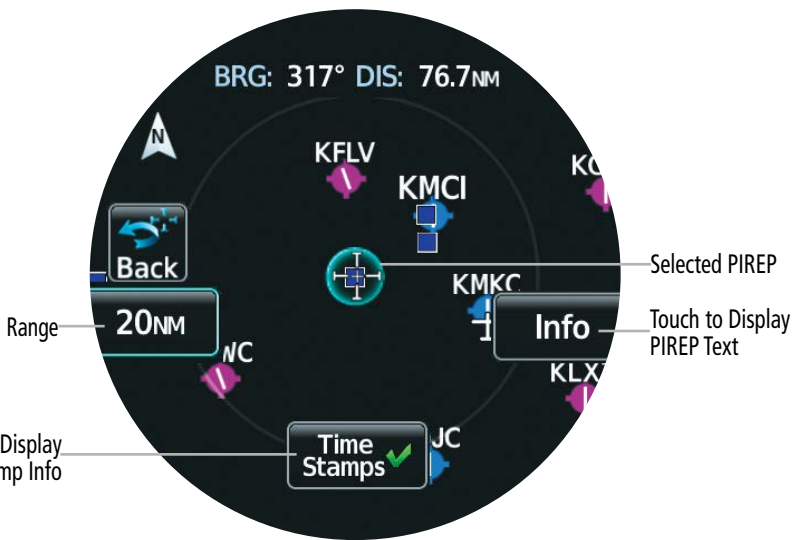

Selected PIREP - 'SXM WX' Page

- System Overview
- Flight Instruments
- EIS
- Navigation
- Hazard Avoidance
- Autopilot
- WSI
- Additional Features
- Appendices
- Index

Winds Aloft

Winds Aloft data shows the forecasted wind speed and direction at the surface, and at selected altitudes. Altitudes can be displayed in 3,000 ft increments up to 42,000 feet MSL.

Winds Aloft are displayed using wind barbs depending on the selected range. The wind barbs indicate wind speed and direction. The wind streamline indicates wind direction with arrows.

The wind barbs always point in the direction the wind is coming from. The wind speed is depicted using flags at the end of the wind barb. A short wind flag is 5 knots, a long wind flag is 10 knots, and a triangle flag is 50 knots.

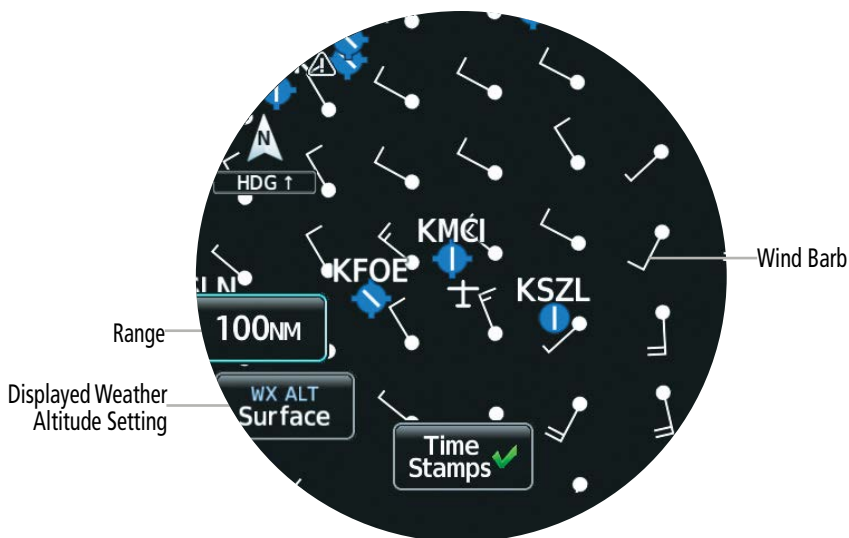

Winds Aloft - 'SXM WX' Page

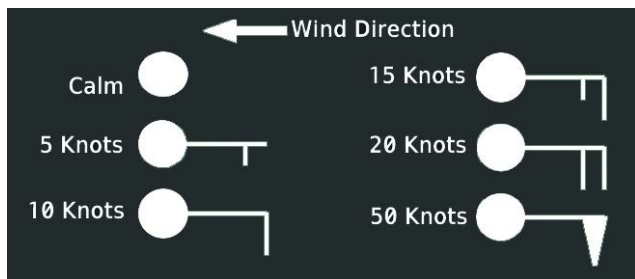

Wind Barb Symbols

Temporary Flight Restrictions (TFR)



WARNING: Do not rely solely upon datalink services to provide Temporary Flight Restriction (TFR) information. Always confirm TFR information through official sources such as Flight Service Stations or Air Traffic Control.

Temporary Flight Restrictions (TFRs) temporarily restrict all aircraft from entering the selected airspace unless a waiver has been issued. TFRs are routinely issued for activities such as sporting events, dignitary visits, military depots, and forest fires. TFRs are represented as an area outlined in yellow.

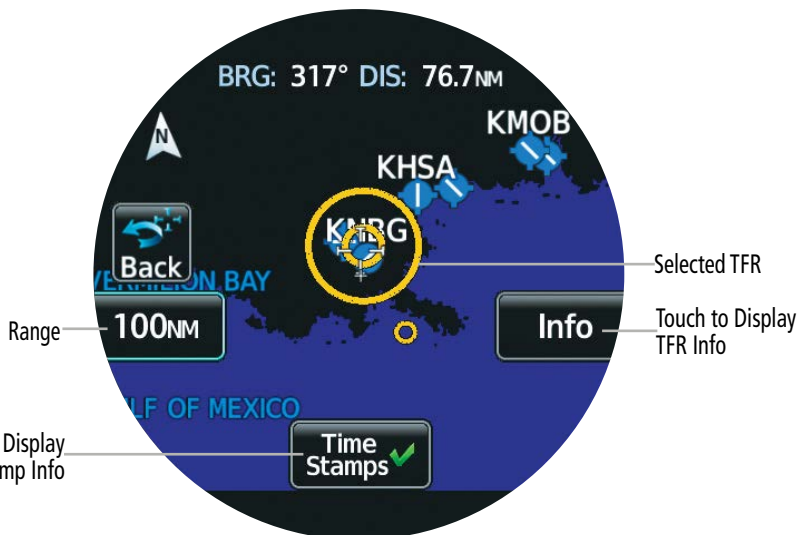

TFR - Weather Page

NEXRAD

NEXRAD (NEXt-generation RADar) is a network of multiple high-resolution Doppler radar sites that are operated by the National Weather Service (NWS). NEXRAD data provides centralized meteorological information for the continental United States and selected overseas locations. The maximum range of a single NEXRAD radar site is 250 nm. In addition to a wide array of services, the NEXRAD network provides important information about severe weather and air traffic safety. NEXRAD data is not real-time. The lapsed time between collection, processing, and dissemination of NEXRAD images can be significant and may not reflect the current radar synopsis.

Composite NEXRAD data is composed of the maximum reflectivity from the individual radar sweeps. The display of the information is color-coded to indicate the weather severity level.

The display of radar coverage is always active when NEXRAD is selected. Areas where NEXRAD radar coverage is not currently available or is not being collected will be depicted as 'No Radar Coverage' until coverage is restored.

There are possible abnormalities regarding displayed NEXRAD images. Some, but not all, of those include:

- Ground clutter

- Strobes and spurious radar data

- Sun strobes (when the radar antenna points directly at the sun)

- Military aircraft deploy metallic dust (chaff) which can cause alterations in radar scans

- Interference from buildings or mountains, which may cause shadows

Certain limitations exist regarding the NEXRAD radar displays. Some, but not all, are listed for the pilot's awareness:

- NEXRAD base reflectivity does not provide sufficient information to determine cloud layers or precipitation characteristics (hail vs. rain). For example, it is not possible to distinguish between wet snow, wet hail, and rain.

- NEXRAD base reflectivity is sampled at the minimum antenna elevation angle. An individual NEXRAD site cannot depict high altitude storms at close ranges and has no information about storms directly over the site.

- Radar coverage only extends to 55°N.

Reflectivity is the amount of transmitted power returned to the radar receiver. Colors on the NEXRAD display directly correlate to the level of detected reflectivity. Reflectivity as it relates to hazardous weather can be very complex. The role of radar is essentially to detect moisture in the atmosphere. Simply put, certain types of weather reflect radar better than others. The intensity of a radar reflection is not necessarily an indication of the weather hazard level. For instance, wet hail returns a strong radar reflection, while dry hail does not. Both wet and dry hail can be extremely hazardous.

Colors are used to identify the different NEXRAD echo intensities (reflectivity) measured in dBZ (decibels of Z). "Reflectivity" (designated by the letter Z) is the amount of transmitted power returned to the radar receiver. The dBZ values increase as returned signal strength increases. Precipitation intensity is displayed using colors corresponding to the dBZ values.

- System Overview
- Flight Instruments
- EIS
- Navigation
- Hazard Avoidance**
- Autopilot
- WSI
- Additional Features
- Appendices
- Index

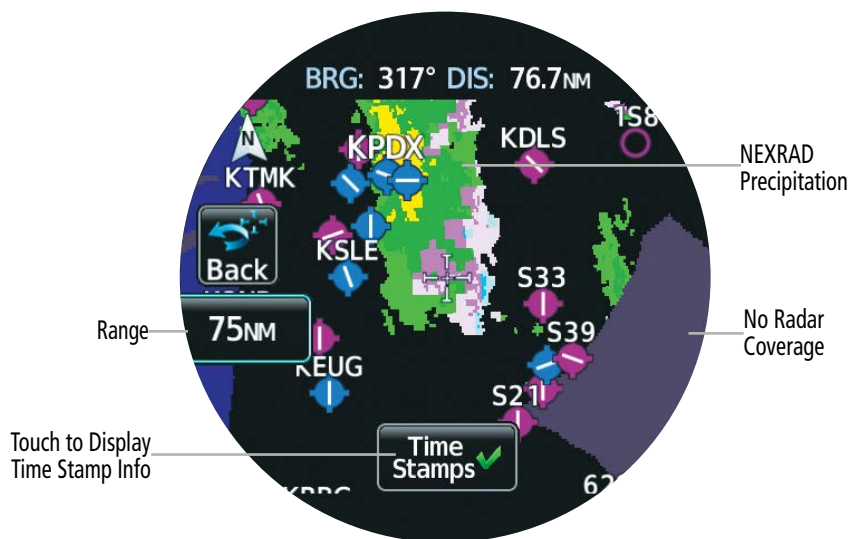

NEXRAD - Weather Page

SIRIUSXM NEXRAD SOURCE SELECTION

Source selection for SiriusXM radar imagery includes the following:

- Composite – Displays composite reflectivity image scanned from multiple elevation angles
- Base – Displays base reflectivity image scanned from a single elevation angle

FIS-B NEXRAD SOURCE SELECTION

FIS-B weather provides two different radar products: CONUS and Regional. Source selection of FIS-B radar includes the following:

- Regional – Displays high resolution weather image of current region
- CONUS – Displays low resolution weather image of the continental US
- Combined – Display of both Regional and CONUS imagery

Lightning

Lightning data shows the approximate location of cloud-to-ground lightning strikes. A strike icon represents at least one strike that has occurred within a two-kilometer region and within the last seven minutes. The exact location of the lightning strike is not displayed.

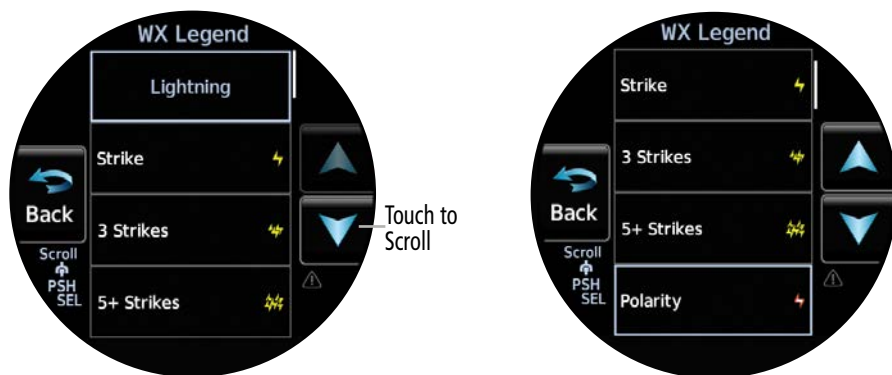
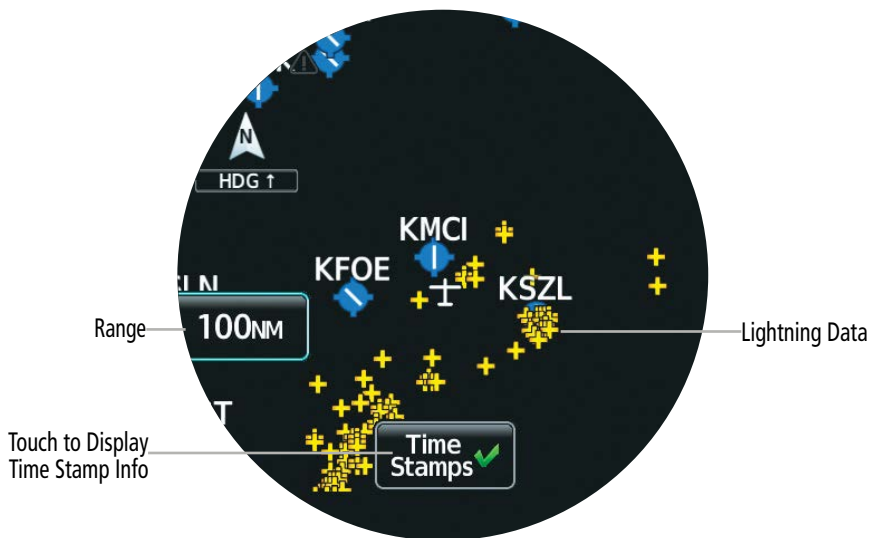

Cloud Tops



NOTE: The broadcast rate for Cloud Tops is 30 minutes. As with all SiriusXM & FIS-B Weather products, the product age becomes yellow when it reaches half of the expiration time, which is 60 minutes for Cloud Tops. Therefore, this weather product age may be yellow during routine operation.

The Cloud Tops weather product depicts cloud top altitudes as determined from satellite imagery. Cloud top altitude is provided in the Information Banner displayed at the top of the screen when panning the specified weather Page.

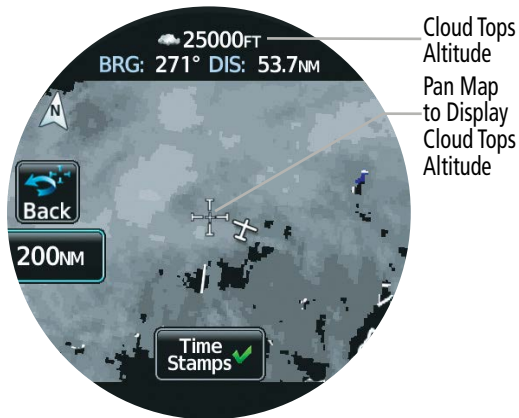
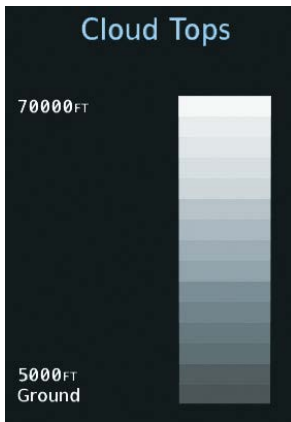

Cloud Tops Legend and Display

Cell Movement (SiriusXM)

The Cell Movement weather product displays the location and projected path of storm cells as identified by the ground-based system.

Cells are represented by orange squares, with direction of movement indicated with short, orange arrows. Critical information about the storm cell (tops and intensity) can be viewed by touching the storm cell.

- System Overview
- Flight Instruments
- EIS
- Navigation
- Hazard Avoidance
- Autopilot
- WSI
- Additional Features
- Appendices
- Index

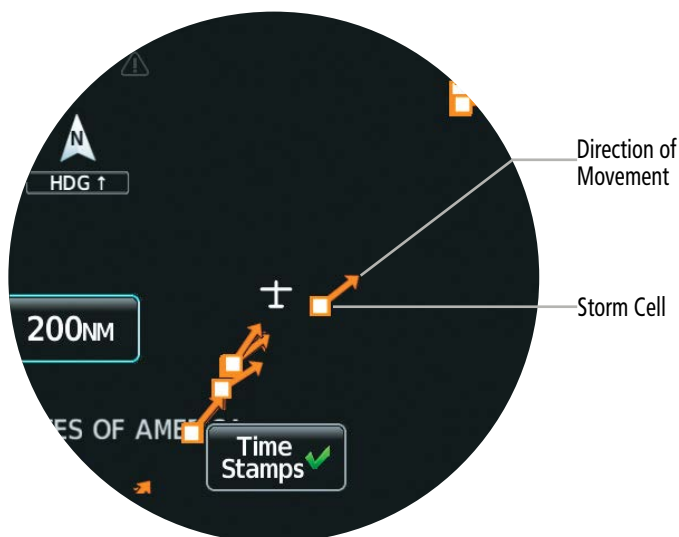

Cell Movement - 'SXM WX' Page

Freezing Levels (SiriusXM)

The Freezing Level weather product shows the color-coded contour lines for the altitude and location at which the freezing level isotherm is found. When no data is displayed for a given altitude, the data for that altitude has not been received, or is out of date and has been removed from the display. New data appears when it becomes available.



Freezing Levels - 'SXM WX' Page

Icing Forecast (CIP & SLD)

Current Icing Product (CIP) data shows a graphical view of the current icing environment. Icing severity is displayed in four categories: trace, light, moderate, and heavy. The CIP product is not a forecast, but a representation of the current conditions at the time of the analysis as determined by a computer model.

Supercooled Large Droplet (SLD) icing conditions are characterized by the presence of relatively large, super cooled water droplets indicative of freezing drizzle and freezing rain aloft. SLD threat areas are depicted over the CIP colors.

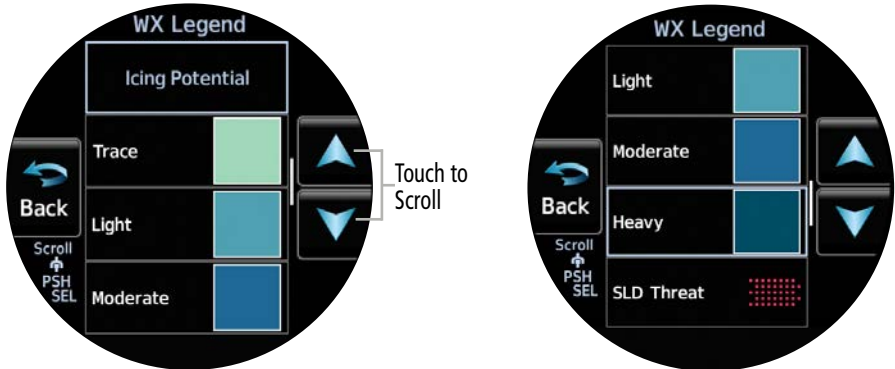

FIS-B Icing Legend

County Warnings (SiriusXM)

The County Warnings weather product provides specific public awareness and protection weather warnings from the National Weather Service (NWS). This can include information on tornadoes, severe thunderstorms, and flood conditions.



County Warnings Symbols

- System Overview
- Flight Instruments
- EIS
- Navigation
- Hazard Avoidance
- Autopilot
- WSI
- Additional Features
- Appendices
- Index

Cyclone (SiriusXM)

The Cyclone weather product shows the current location of cyclones (hurricanes), tropical storms, and their projected tracks. The system displays projected track information in the form of DD/HH/MM.

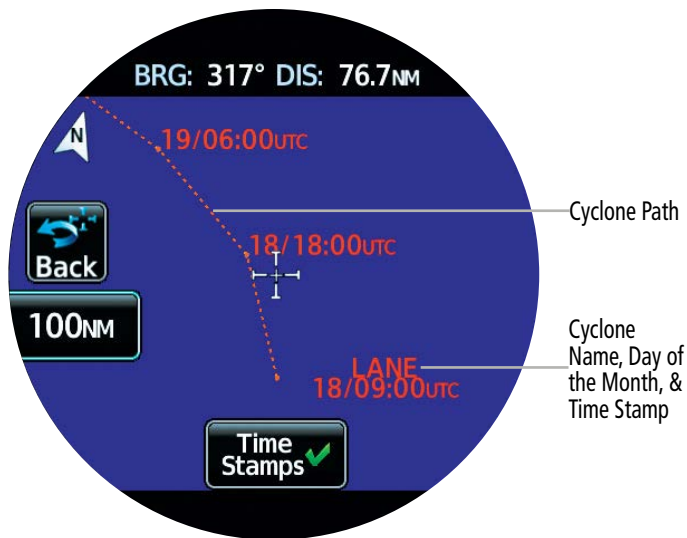

Cyclone Projected Path - 'SXM WX' Page

Surface Analysis and City Forecast (SiriusXM)

Surface Analysis and City Forecast information is available for current and forecast weather conditions. Forecasts are available for intervals of 12, 24, 36, and 48 hours.



Surface Analysis Symbols

- System Overview
- Flight Instruments
- EIS
- Navigation
- Hazard Avoidance**
- Autopilot
- WSI
- Additional Features
- Appendices
- Index



City Forecast Symbols

Turbulence

The Turbulence weather product identifies the potential for erratic movement of high-altitude air mass associated winds. Turbulence is classified as light, moderate, severe, or extreme, at altitudes between 21,000 ft and 45,000 ft. Turbulence information is intended to supplement AIRMETs, SIGMETs, and PIREPs.

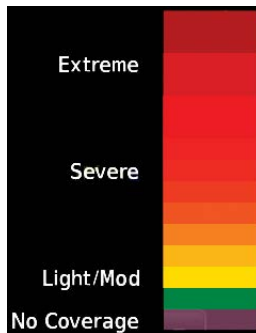

Turbulence Legend

WEATHER PRODUCT AGE

Unlike real-time weather information collected directly from weather sensors on-board an aircraft, such as an airborne weather radar or a lightning detection system, datalink weather in contrast relies on external service providers to collect, process, and transmit weather information to the aircraft. This information can come from a variety of sources such as government agencies.



NOTE: Due to the time it takes to collect, process, and distribute datalink weather information, it is imperative for pilots to understand that datalink weather information is not real-time information and may not accurately depict current conditions.

Each datalink weather product has a weather product age. This age represents the elapsed time, in minutes, since the weather product was compiled. It does not represent the age of the information contained within the weather product itself. SiriusXM and FIS-B weather products are broadcast automatically on a repeating cycle without pilot intervention.

Each datalink weather product has an expiration time. The weather product age is shown in white if it is less than half of this expiration time, otherwise it is shown in yellow until reaching its expiration time. After a weather product has expired, the system removes the expired weather product and shows white dashes instead of the age. If the datalink receiver has not yet received a weather product 'No Data' appears instead of the age to show the product is currently not available for display. This may occur, for example, after powering on the system but before the datalink receiver has received a complete weather data transmission. It could also indicate a possible outage of a weather product.

The following table shows the expiration times for each weather product. The service provider and its weather data suppliers define and control the data update intervals, which are subject to change.



| Weather Product | Expiration Time |
|------------------------------------|-----------------|
| METARs | 90 minutes |
| TAFs | 60 minutes |
| SIGMETs/AIRMETs | 60 minutes |
| Pilot Weather Report (PIREP) | 90 minutes |
| Winds Aloft | 90 minutes |
| Temporary Flight Restriction (TFR) | 60 minutes |
| Radar Precipitation (NEXRAD) | 30 minutes |
| Lightning | 30 minutes |
| Cloud Top | 60 minutes |
| *Echo Top | 30 minutes |

| Weather Product | Expiration Time |
|-------------------------------|-----------------|
| *Cell Movement | 30 minutes |
| *Freezing Levels | 120 minutes |
| Icing Potential (CIP and SLD) | 90 minutes |
| *County Warnings | 60 minutes |
| *Cyclone Warnings | 60 minutes |
| *City Forecast | 90 minutes |
| *Surface Analysis | 60 minutes |
| *Air Report (AIREP) | 90 minutes |
| Turbulence | 180 minutes |

*SiriusXM required

Weather Products Expiration Time

A time stamp identifies the approximate time of data collection for each weather product. For quick reference, a Time Stamps Button is displayed at the bottom of the weather page. See the table below for the different icons which may be displayed on the Time Stamps Button. Select the Time Stamps Button to display information about each weather product and product age.

| Time Stamp Symbols | |
|---|--|
|  | All selected weather products are considered current. Product ages are newer than half the expiration times. |
|  | One or more weather product is considered stale. Its age is older than half its expiration time. A weather product may be yellow when its issue date and time occurs in the future by more than the completed expiration time for the requested weather product. |
|  | One or more weather product has expired, or data is not available at the selected altitude, or has not been received. |

The color of each weather product listed on the 'Time Stamps' Screen will change depending on the status of each weather product, as shown in the figure below.

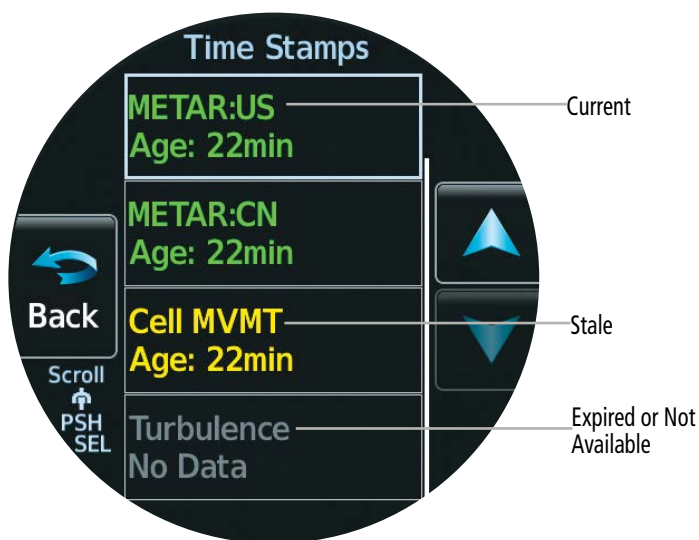

'Time Stamps' Screen

DISPLAY OF WEATHER PRODUCTS

Datalink Weather Products can be displayed on the respective weather page ('SXM WX' Page, or 'FIS-B WX' Page). Some Weather Products may also be overlaid on the 'HSI Map' Page and the 'Map' Page. See the Map Options discussion of the Navigation Section for more information on weather overlay options for other map pages.

Each weather product listed in the page options menu may be enabled or disabled for display. The annunciator bar on the button will be green when an item is enabled for display. Some weather products may have other settings available for selection. A Legend of weather products is also available.

The display of radar weather products (NEXRAD) will depend on the radar source selection.

If more information is available, such as a textual report for the weather product, that information can be displayed by touching the weather product on the weather page, and then selecting the **Info** Button.

Enabling/disabling datalink weather products on the weather page:

- 1) From the 'SXM WX' Page, open the page menu and select **SXM WX Options > Layers**.
Or:
From the 'FIS-B WX' Page, open the page menu and select **FIS-B WX Options > Layers**.
- 2) Select the desired Weather Product Button. The weather product is enabled for display when the annunciator bar is green.
- 3) Scroll the list as necessary and select each Weather Product Button to enable/disable as desired.

Displaying information for a selected weather product:

- 1) Select the 'SXM WX' Page.
Or:
Select the 'FIS-B WX' Page.
- 2) Touch the desired weather product icon.
Or:
Touch and drag to pan to the location of the desired weather product icon. Then, touch the desired weather product icon.
- 3) Select the **Info** Button. The 'WX Data' Screen is displayed showing the information available for the selected weather product.

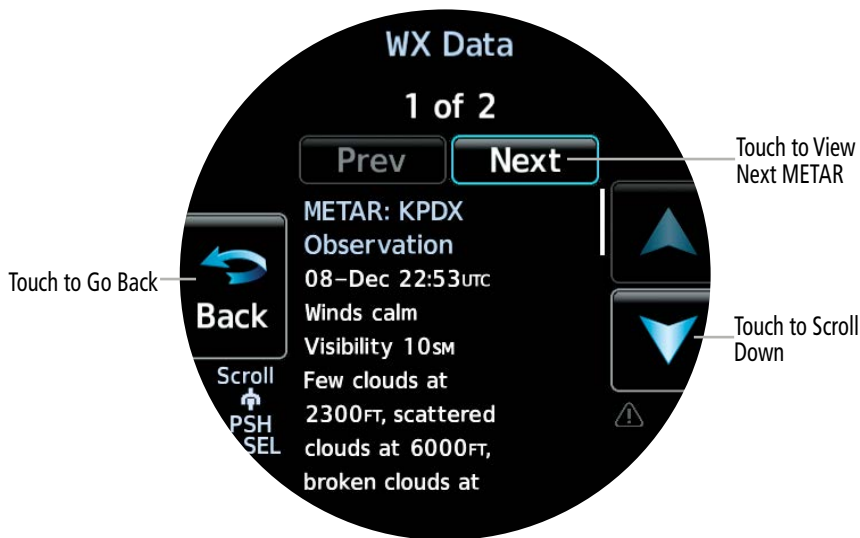

METAR Product Info - 'WX Data' Screen

Viewing the Legend of weather products:

- 1) From the 'SXM WX' Page, open the page menu and select **SXM WX Options**.

Or:

From the 'FIS-B WX' Page, open the page menu and select **FIS-B WX Options**.

- 2) Select the **Legend** Button. A legend of selected weather products is displayed.

Changing the altitude setting for the Winds Aloft, Icing, and Turbulence on the weather page:

- 1) Select the 'SXM WX' Page.

Or:

Select the 'FIS-B WX' Page.

- 2) When Winds Aloft, Icing, and/or Turbulence is enabled for display, the **WX ALT** Button is displayed on the weather page. Touch the **WX ALT** Button. The button is highlighted indicating it is active.
- 3) Turn the Small Knob clockwise to increase the altitude setting or counter-clockwise to decrease the altitude setting.

Changing the AIRMET settings:

- 1) From the 'SXM WX' Page, open the page menu and select **SXM WX Options > Layers**.

Or:

From the 'FIS-B WX' Page, open the page menu and select **FIS-B WX Options > Layers**.

- 2) Select the **AIRMET Settings** Button to display the 'AIRMET Setup' Screen.
- 3) Scroll the list as necessary and select each AIRMET Type Button to enable/disable as desired.

Changing the county warnings settings:

- 1) From the 'SXM WX' Page, open the page menu and select **SXM WX Options > Layers**.
- 2) Select the **County Warning Settings** Button to display the 'County Setup' Screen.
- 3) Select each Warning Type Button to enable/disable as desired.

Selecting which surface analysis and/or city forecast to display:

- 1) From the 'SXM WX' Page, open the page menu and select **SXM WX Options > Layers**.
- 2) Select the **Surface Analysis** Button to display the 'Forecast' Screen. A list of available surface analysis forecasts is displayed.

Or:

Select the **City Forecast** Button to display the 'Forecast' Screen. A list of available city forecasts is displayed.

- 3) Select the desired Forecast Button, or select the **Off** Button to disable the display of the forecast.

5.3 STORMSCOPE LIGHTNING DETECTION SYSTEM



WARNING: Do not rely on information from a lightning detection system display as the sole basis for hazardous weather avoidance. Range limitations and interference may cause the system to display inaccurate or incomplete information. Refer to documentation from the lightning detection system manufacturer for detailed information about the system.

When configured with a Stormscope Weather Mapping Sensor, Stormscope lightning detection information may be displayed on the 'Lightning' Page.

The symbols shown in the following table will be displayed to depict lightning strikes and cells based on the age of the information.

| Lightning Age | Symbol |
|--|--------|
| Strike is less than 6 seconds old | |
| Strike is between 6 and 60 seconds old | |
| Strike is between 1 and 2 minutes old | |
| Strike is between 2 and 3 minutes old | |

Lightning Age and Symbols

STORMSCOPE OPTIONS



NOTE: When using Stormscope, there are several atmospheric phenomena in addition to nearby thunderstorms that can cause isolated discharge points in the strike display mode. However, clusters of two or more discharge points in the strike display mode do indicate thunderstorm activity if these points reappear after the screen has been cleared.

On the 'Lightning' Page, lightning information can be displayed at the ranges of 25 nm, 50 nm, 100 nm, and 200 nm. The current range is indicated on the Range Button. Range may be changed by zooming in and out. To change the range, select the Range Button, and then turn the Small Knob clockwise to zoom in and decrease the range, or counterclockwise to zoom out and increase the range.

Stormscope data may be displayed in 360° View or Arc View. Additionally, two modes are available for display:

- Cell Mode identifies cluster of electrical activity, grouping individual strikes together
- Strike Mode displays the relative location of each discharge strike; the 'Rate' displays the approximate number of strikes per minute for a given range

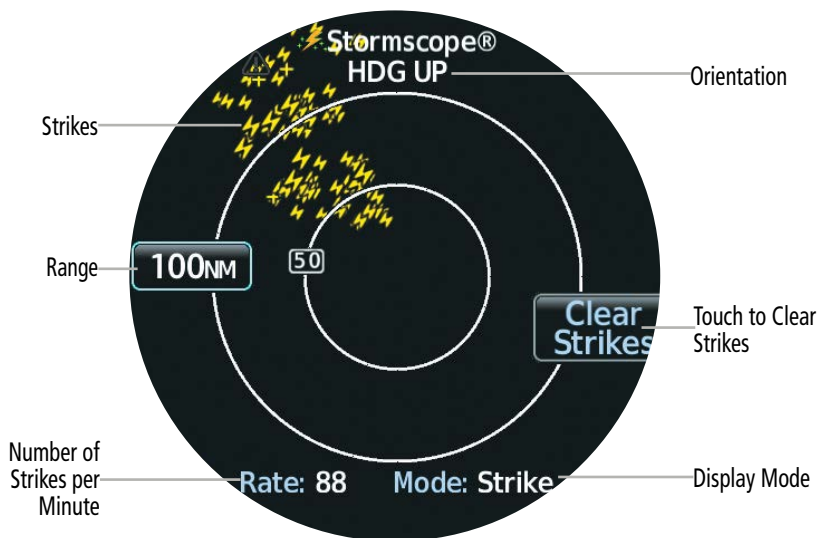

Stormscope 'Lightning' Page

Selecting the Stormscope view:

- 1) From the 'Lightning' Page, open the page menu and select **Lightning Opts.**
- 2) Select the **View** Button to toggle between 360° and Arc.

Selecting the Stormscope mode:

- 1) From the 'Lightning' Page, open the page menu and select **Lightning Opts.**
- 2) Select the **Mode** Button to toggle between Cell and Strike.

If heading input is lost, strikes and/or cells must be cleared manually after the execution of each turn. This is to ensure the strike and/or cell positions are depicted accurately in relation to the nose of the aircraft.

Manually clearing Stormscope cell or strike information:

From the 'Lightning' Page, select the **Clear Strikes** Button.

5.4 TERRAIN



WARNING: Do not use Terrain information for primary terrain avoidance. Terrain information is intended only to enhance situational awareness.



NOTE: Terrain data is not displayed when the aircraft is outside of the installed terrain database coverage area.



NOTE: Terrain and obstacle alerting is not available north of 89° North latitude and south of 89° South latitude. This is due to limitations present within the Terrain database and the system's ability to process the data representing the affected areas.



NOTE: No terrain or obstacle alerting occurs if Terrain Proximity is the only terrain function configured.

The following terrain configurations are allowed:

| Terrain Function | Description |
|---------------------------------|---|
| (H) Terrain Proximity | Displays relative terrain and obstacle data. |
| (H) Terrain-FLTA | Displays relative terrain and obstacle data and provides aural and visual alerts for potential flight path conflicts involving terrain or obstacles |
| External TAWS-B/HTAWS Interface | External TAWS-B/HTAWS system provides terrain data and alerts which can be displayed on the MFI |
| Other external TAWS | See the pertinent flight manual for the external TAWS equipment |

Terrain Configurations

The following is required for proper terrain display operation:

- Valid 3-D GPS position
- Valid terrain and obstacle databases

A GPS source is used to receive a horizontal position and altitude with terrain data. GPS altitude is derived from satellite measurements. GPS altitude is then converted to the height above geodetic sea level (GSL), which is the height above mean sea level (MSL) calculated geometrically. GSL altitude is used to determine terrain alerts (if configured). GSL altitude accuracy is affected by satellite geometry but is not subject to variations in pressure and temperature that normally affect pressure altitude sensors. GSL altitude does not require local altimeter settings to determine MSL altitude. It is a widely-used MSL altitude source. Therefore, GSL altitude provides a highly accurate and reliable MSL altitude source to calculate terrain and obstacle alerts.

The terrain and obstacle databases are referenced to MSL. Using the GPS position and GSL altitude, a 2-D terrain display is created, showing the surrounding terrain and obstacles relative to the position and altitude of the aircraft. Furthermore, when configured with (H) Terrain-FLTA, GPS position and GSL altitude are used to calculate and “predict” the aircraft’s flight path in relation to the surrounding terrain and obstacles. In this manner, the (H) Terrain-FLTA can provide advanced alerts of predicted dangerous terrain conditions.

Baro-corrected altitude (or indicated altitude) is derived by adjusting the altimeter setting for local atmospheric conditions. The most accurate baro-corrected altitude can be achieved by frequently updating the altimeter setting to the nearest reporting station along the flight path. However, because actual atmospheric conditions seldom match the standard conditions defined by the International Standard Atmosphere (ISA) model (where pressure, temperature, and lapse rates have fixed values), it is common for the baro-corrected altitude (as read from the altimeter) to differ from the GSL altitude.

Terrain functionality uses colors and symbols to represent terrain and obstacles (with heights greater than 200 feet above ground level, AGL) present in the databases relative to aircraft altitude. The colors automatically change as the aircraft altitude changes.

Terrain above or within 100 feet below the aircraft altitude is depicted in red. Terrain between 100 feet and 1000 feet below the aircraft altitude is depicted in yellow. The color black indicates terrain is more than 1000 feet below the aircraft altitude. For the helicopter terrain depictions, Terrain above 250 feet of the rotorcraft altitude is depicted in Red. Terrain between 250 feet and 0 (zero) feet is depicted as Orange. Terrain between 0 (zero) feet and 250 feet below is depicted as yellow. Terrain between 250 feet and 500 feet below is depicted as green. Terrain more than 500 feet below is depicted as black.

For additional safety, wire obstacle data is provided by Garmin’s WireAware™ database. The database mainly includes Hazardous Obstacle Transmission (HOT) power lines which are typically high voltage transmission lines depicted on VFR Sectional charts and are considered of special interest to fixed-wing pilots. These include power lines which are in close proximity to airports/heliports and power lines which span rivers, valleys, and canyons.

It is important to note the database does not contain all power lines. In fact, WireAware database coverage is mostly limited to HOT power lines. Furthermore, WireAware obstacle database coverage exists mainly in the United States; with limited coverage in portions of Canada and Mexico.

The following figure shows the relative terrain coloring.

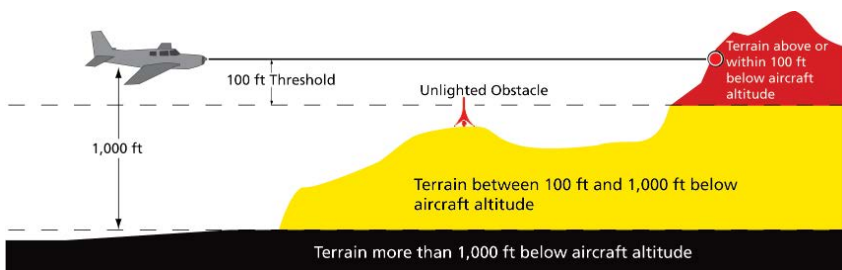

Relative Terrain Altitude/Color Correlation - Fixed Wing

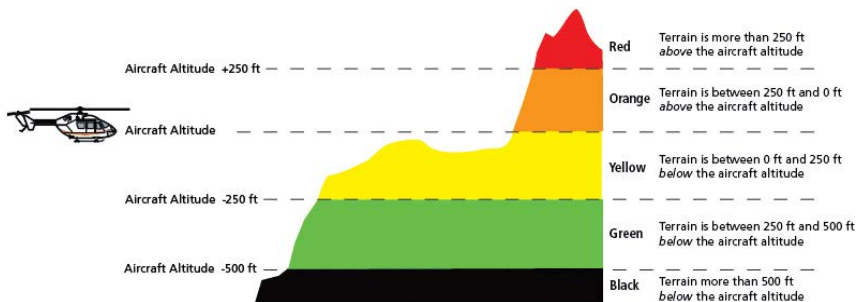



Relative Terrain Altitude/Color Correlation - Rotorcraft







The following tables show relative obstacle and wire symbols and coloring used by the terrain systems.

| | Unlighted Obstacle | | Lighted Obstacle | | Obstacle Location | |
|---------------------|--------------------|--------------|------------------|--------------|---|--|
| | < 1,000' AGL | > 1,000' AGL | < 1,000' AGL | > 1,000' AGL | Fixed Wing | Rotorcraft |
| Additional Features | | | | | Red obstacle is above or within 100 ft below current altitude. | Red obstacle is at or above current altitude. |
| Appendices | | | | | Yellow obstacle is between 100 ft and 1,000 ft below current altitude. | Yellow obstacle is within 250 ft below current altitude. |
| Index | | | | | White obstacle is more than 1,000 ft and 2,000 ft below current altitude. | White obstacle is more than 250 ft below current altitude. |

Relative Obstacle Symbols and Colors







| Wire Obstacle | Wire Obstacle Location |
|--|--|
|  | Red wire obstacle is above or within 100 ft below aircraft altitude |
|  | Yellow wire obstacle is between 100 ft and 1000 ft below aircraft altitude |
|  | White wire obstacle is more than 1000 ft below aircraft altitude |

Relative Wire Obstacles and Colors

| Unlighted Wind Turbine Obstacle | Lighted Wind Turbine Obstacle | Wind Turbine Obstacle Location | |
|---|---|---|--|
| | | Fixed Wing | Rotorcraft |
|  |  | Red obstacle is above or within 100 ft below current altitude. | Red obstacle is at or above current altitude. |
|  |  | Yellow obstacle is between 100 ft and 1000 ft below current altitude. | Yellow obstacle is within 250 ft below current altitude. |
|  |  | White obstacle is more than 1000 ft below current altitude. | White obstacle is more than 250 ft below current altitude. |

Wind Turbine Obstacles and Colors

Potential impacts areas will be displayed for terrain and obstacles as shown in the following table (not available with Terrain Proximity or other manufacturer external TAWS).

| Potential Impact Area Examples | Alert Type | Example Annunciation |
|--|------------|---|
|  or  | Warning |  |
|  or  | Caution |  |

Terrain Potential Impact Area with Annunciations

With the exception of power lines, obstacles within close proximity of each other may display as a group.

| Obstacle Groups | Obstacle Groups Location |
|---|---|
|  | Asterisk indicates the obstacle belongs to a group. |
| | Relative altitude of the highest obstacle determines color. |
| | Depiction is of the most immediate threat. |

Relative Obstacle Groups and Colors

DISPLAYING TERRAIN DATA

Terrain and obstacle information can be displayed on the 'Map' Page and the 'HSI Map' Page. When terrain and/or obstacle data is overlaid on maps, an icon is displayed for each type of feature enabled for display depending on the current range setting. For more information on terrain overlay options on map pages, and which unit configurations offer map pages, see the Map Options discussion in the Navigation Section. If configured as a Standby ADI or an MFD, the 'Terrain' Page will be available. The 'Terrain' Page is the principal map page for viewing terrain and obstacle information relative to the aircraft current GSL altitude. Map orientation on this page is always heading up unless there is no valid heading, in which case the orientation is track up. A legend is available for display. Additionally, active flight plan information may be overlaid on the 'Terrain' Page. Terrain data may be displayed in 360° View or Arc View. The 'Terrain' Page has seven range settings available between 1 and 100 NM. The current range is indicated on the Range Button. Range may be changed by zooming in and out using the Small Knob.

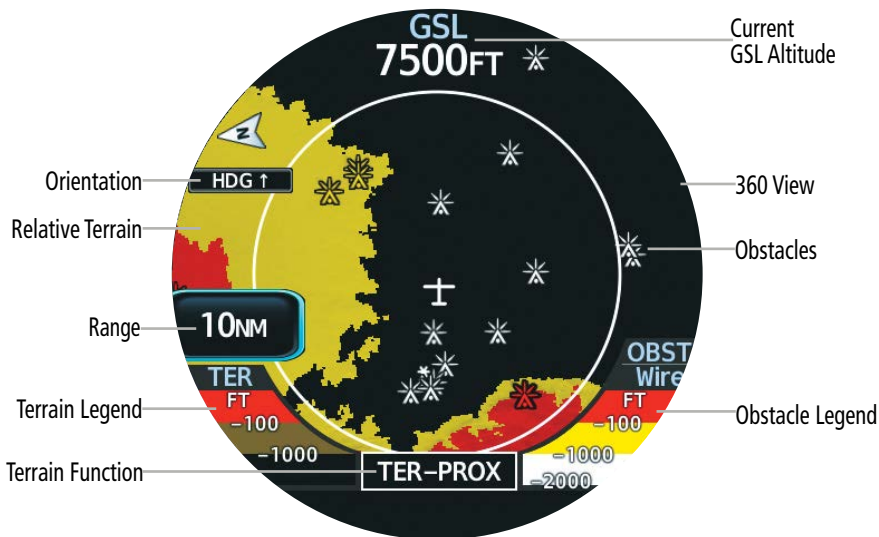



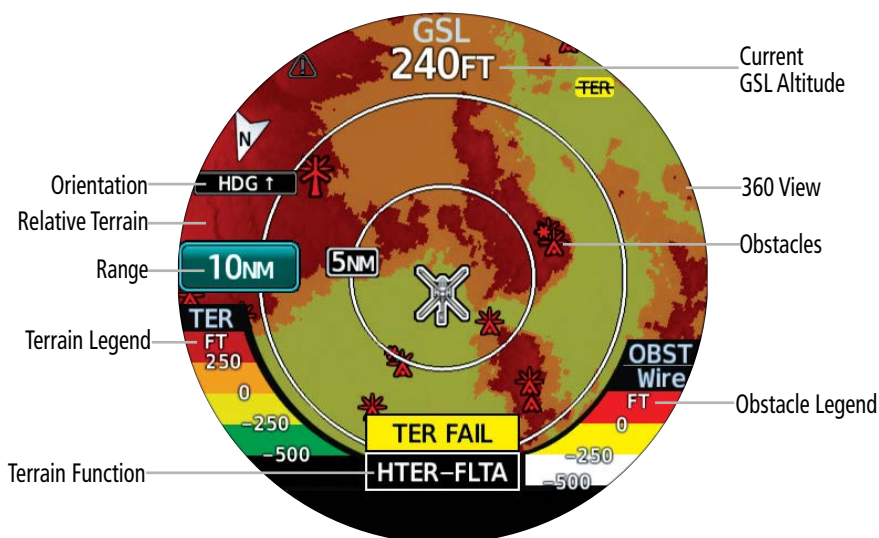



'Terrain' Page - Fixed Wing
Garmin GI 275 Pilot's Guide

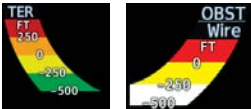

'Terrain' Page - Rotorcraft

When Terrain-FLTA or TAWS-B data is available, potential impact areas will be indicated. If an obstacle and the projected flight path of the aircraft intersect, the display automatically adjusts the range setting to emphasize the display of the potential impact area.

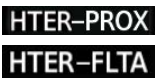
Terrain and obstacle information can also be displayed on the 'Map' Page and the 'HSI Map' Page. When terrain and/or obstacle data is overlaid on maps other than the 'Terrain' Page, an icon is displayed for each type of feature enabled for display depending on the current range setting. Terrain information can be overlaid independently of obstacle data; however, obstacles identified by Terrain Proximity as yellow or red are shown when terrain is selected for display and the map range is within the setting limit. Additional information about obstacles can be displayed using the panning function on the 'Map' Page. For more information on terrain overlay options on other maps, see the Map Options discussion in the Navigation Section. See the Map Panning discussion of the Navigation Section for instructions on panning the map.

| Item Displayed | Description |
|---|---|
| GSL Altitude  | Displays current GPS height above mean sea level on the 'Terrain' Page. |
| Legend - Fixed Wing  | Displays legend of color designations for terrain and obstacle relative altitude ranges for fixed wing aircraft. |
| Legend - Rotorcraft  | Displays legend of color designations for terrain and obstacle relative altitude ranged for rotorcraft. |
| Terrain Function Identifier - Fixed Wing  | Indicates the active terrain function on the 'Terrain' Page for fixed wing aircraft. |
| Terrain Function Identifier - Rotorcraft  | Indicates the active terrain function on the 'Terrain' Page for rotorcraft. |
| Terrain Overlay Icons  | Indicates when terrain or obstacles are displayed for the current range setting when enabled on the 'Map' Page and the 'HSI Map' Page |

Terrain Display Items

Selecting the 'Terrain' Page view:

- 1) From the 'Terrain' Page, open the page menu and select **Terrain Options**.
- 2) Select the **View** Button to toggle between 360° and Arc.

Displaying active flight plan information on the 'Terrain' Page:

- 1) From the 'Terrain' Page, open the page menu and select **Terrain Options**.
- 2) Select the **Flight Plan** Button to enable/disable the flight plan overlay setting.

Displaying the legend on the 'Terrain' Page:

- 1) From the 'Terrain' Page, open the page menu and select **Terrain Options**.
- 2) Select the **Legend** Button to enable/disable the display of the legend.

TERRAIN ALERTS

Alerts are issued when flight conditions meet parameters that are set by the configured terrain function. Terrain alerts typically employ a CAUTION or a WARNING alert severity level, or both. When an alert is issued, visual annunciators are displayed.

Forward Looking Terrain Avoidance ((H) FLTA) compares the projected flight path as derived from GPS data with terrain features and obstacles from the terrain and obstacle databases. FLTA alerts are issued when the projected flight path conflicts with terrain or obstacles. The projected flight path is a calculated area ahead of, to the sides, and below the aircraft. The size of the projected flight path varies based on factors including ground speed (the path ahead is larger when the ground speed is higher), whether the aircraft is level, turning, or descending, and the proximity to the nearest runway along the current track. As the aircraft approaches the runway, the projected flight path becomes narrower until FLTA is disabled or alerts are inhibited. The system automatically disables FLTA alerts when the aircraft is less than 200 feet above the destination runway elevation while within 0.5 nm of the approach runway or the aircraft is between runway ends.

| Flight Phase | Minimum Clearance Altitude | |
|--------------|----------------------------|------------|
| | Level Flight | Descending |
| En Route | 700 ft | 500 ft |
| Terminal | 350 ft | 300 ft |
| Approach | 150 ft | 100 ft |
| Departure | 100 ft | 100 ft |

FLTA Alert Minimum Terrain and Obstacle Clearance Values

In addition to the (H) FLTA alerting discussed previously, external TAWS-B/HTAWS may be configured to provide the following alert types: Excessive Descent Rate, Negative Climb Rate, and Premature Descent.

Terrain Alerts - Primary ADI and Primary HSI

When a threat is detected (terrain, obstacle, or wire), a 'TER' annunciation will be displayed on each page. This annunciation will flash for five seconds before being displayed steady until the threat is cleared. Both caution and warning annunciations may be displayed.



Primary ADI and Primary HSI Terrain Alert Examples

In addition to the 'TER' annunciation, the MFI may also provide aural alerts (the (H) Terrain Proximity function does not provide aural alerts). If an external TAWS-B/HTAWS system is configured, aural alerts are provided by the external system.



NOTE: Only visual annunciations will be provided if the Terrain Function is using an external TAWS-B system. For information on TAWS-B/HTAWS aural alerts, see the pertinent flight manual for that system.

| Alert Type | Aural Alert | Annunciations on All Pages |
|--|---|----------------------------|
| Terrain/Obstacle/Wire Warning (FLTA) | "(Terrain/Obstacle/Wire) Ahead, Pull Up" or "(Terrain/Obstacle/Wire), (Terrain/Obstacle/Wire) Pull Up" | TER |
| Reduced Required Terrain/Obstacle/Wire Clearance Warning | "Warning; (Terrain/Obstacle/Wire), (Terrain/Obstacle/Wire)" | |
| Terrain/Obstacle/Wire Caution | "(Terrain/Obstacle/Wire), Ahead; (Terrain/Obstacle/Wire), Ahead" or "Caution, (Terrain/Obstacle/Wire); Caution, (Terrain/Obstacle/Wire)," | TER |
| Imminent Terrain/Obstacle/Wire Impact Caution | "Caution; (Terrain/Obstacle/Wire), (Terrain/Obstacle/Wire)" | |
| Premature Descent Alert Caution | * | |

*Aural alert provided by the external TAWS-B System

Primary ADI and Primary HSI Terrain Annunciations

Terrain Alerts - Standby ADI and MFD

When a threat is detected, for indicator configurations that provide a Terrain page enabled on the specific indicator, a pop-up alert is displayed when viewing any page other than the 'Terrain' Page. An annunciation is also displayed on the bottom of the 'Terrain' Page. The threat responsible for generating the alert is colored according to its alert level and may be encircled (the Terrain Proximity function does not encircle the threat for display).

To acknowledge a terrain pop-up alert:

Touch the **Close** Button (returns to the currently viewed page), or

Touch the **Inhibit** Button (inhibits alerts and returns to the currently viewed page), or

Touch the **Go to Terrain** Button (accesses the 'Terrain' Page).

Terrain Warning Pop-Up



'Terrain' Page Terrain Warning

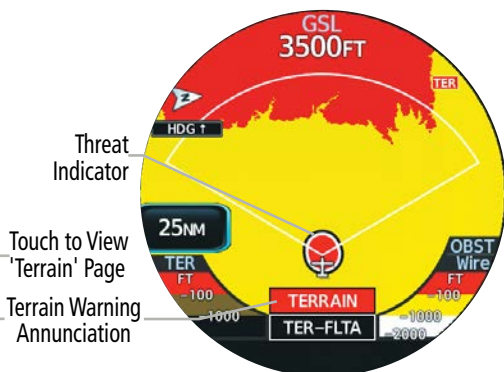

Obstacle Caution Pop-Up



'Terrain' Page Wire Caution

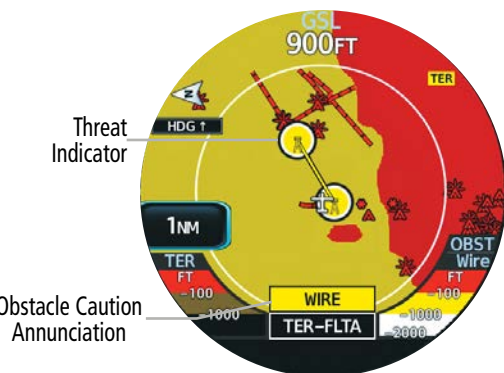

Standby ADI and MFD Terrain Alert Examples - (H) Terrain-FLTA

In addition to the pop-up alert and/or alert annunciation, the MFI may also give aural alerts (the Terrain Proximity function does not provide aural alerts). If an external TAWS-B/HTAWS system is configured, aural alerts may be provided by the external system. For HSI and Standby/HSI display configurations, the Terrain alert will appear only on the Map along with the "TER" annunciation in the top right corner in the corresponding threat color (Red or Amber) depending on threat severity.

- System Overview
- Flight Instruments
- EIS
- Navigation
- Hazard Avoidance**
- Autopilot
- WSI
- Additional Features
- Appendices
- Index

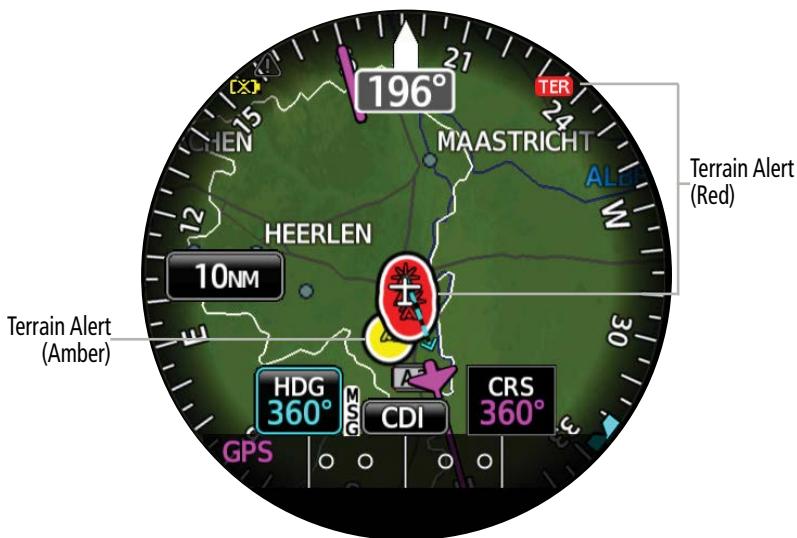

Terrain Alert - 'HSI Map' Page



NOTE: Only visual annunciations will be provided if the Terrain Function is using an external TAWS-B/HTAWS system. For information on TAWS-B/HTAWS voice alerts, see the pertinent flight manual for that system.

| Alert Type | Aural Alert | Annunciations All Pages | Annunciations 'Terrain' Page |
|--|--|-------------------------|--|
| Terrain/Obstacle/Wire Warning (FLTA) | "(Terrain/Obstacle/Wire) Ahead, Pull Up" Or "(Terrain/Obstacle/Wire), (Terrain/Obstacle/Wire) Pull Up" | TER | PULL UP |
| Reduced Required Terrain/Obstacle/Wire Clearance Warning | "Warning; (Terrain/Obstacle/Wire), (Terrain/Obstacle/Wire)" | | TERRAIN Or: OBSTACLE Or: WIRE |

| Alert Type | Aural Alert | Annunciations All Pages | Annunciations 'Terrain' Page |
|---|---|-------------------------|--|
| Terrain/Obstacle/Wire Caution | "(Terrain/Obstacle/Wire), Ahead; (Terrain/Obstacle/Wire), Ahead" Or "Caution, (Terrain/Obstacle/Wire); Caution, (Terrain/Obstacle/Wire)," | TER | TERRAIN Or: OBSTACLE Or: WIRE |
| Imminent Terrain/Obstacle/Wire Impact Caution | "Caution; (Terrain/Obstacle/Wire), (Terrain/Obstacle/Wire)" | | |
| Premature Descent Alert Caution | * | | TERRAIN |

*Aural alert provided by the external TAWS-B System

Standby ADI and MFD Terrain Annunciations

TERRAIN INHIBIT

Terrain alerts may be manually inhibited. Doing so will deactivate all aural and visual annunciations associated with the configured terrain function. Terrain alerts may be manually re-activated at any time. Terrain alerts are automatically activated with each power cycle.

TER

Alerting is Inhibited when Annunciation is Displayed

Manually inhibiting/enabling terrain alerting:

- 1) From the 'Terrain' Page, open the page menu and select **Terrain Options**.
- 2) Select the **Terrain Inhibit** Button to inhibit/enable terrain alerts. The annunciator bar is green when terrain alerts are inhibited.

TERRAIN STATUS

When power is applied to the system, the terrain function conducts a self-test of its visual annunciations and aural alerts. A voice alert is issued at test completion. If an external TAWS-B system is configured to interface with the MFI, test annunciations for TAWS may be displayed on the MFI.

The test may also be manually initiated. The option to run a terrain test may be disabled when the ground speed exceeds 30 knots, depending on the terrain function configuration. The following table shows the different terrain status annunciations and conditions that may occur.

| Alert Type | Aural Alert | Annunciations All Pages | Annunciations 'Terrain' Page |
|---|----------------------------------|-------------------------|------------------------------|
| Terrain test in progress | None | TER | TER TEST |
| Terrain alerting inhibited | None | | TER INHB |
| No GPS position | "Terrain System Not Available" * | TER | TER N/A |
| Excessively degraded GPS signal or out of database coverage area | "Terrain System Not Available" * | | TER N/A |
| Terrain test fail; Terrain or Obstacle database unavailable or invalid; Invalid software configuration; or system audio fault | "Terrain System Failure" | | TER FAIL |
| External TAWS system test in progress | ** | | TAWS TEST |
| External TAWS system Alerting Inhibited | ** | TER | TAWS INHB |
| External TAWS system fail | ** | TER | TAWS FAIL |
| External TAWS not available | ** | | TAWS N/A |
| Reduced Protection Enabled | None | RP | RP MODE |

* "Terrain System Available" will be heard when sufficient GPS signal is received, or Terrain database coverage area re-entered.

** Aural alert provided by the external TAWS-B System

Terrain System Status Annunciations

SYNTHETIC VISION TERRAIN

Terrain is integrated within Synthetic Vision (when active) to provide land contours (colors are consistent with those of the topographical map display), large water features, towers, obstacles over 200' AGL, as well as visual and auditory alerts to indicate the presence of terrain and obstacle threats relevant to the projected flight path. Synthetic Vision terrain information is displayed in red and yellow shading on the 'ADI' Page. Refer to the Additional Features Section (Synthetic Vision) for more information.

5.5 TRAFFIC



WARNING: Do not rely solely upon the display of traffic information for collision avoidance maneuvering. The traffic display does not under any circumstances or conditions relieve the pilot's responsibility to see and avoid other aircraft.



WARNING: Always use traffic information shown on system displays only as an aid to visually acquiring traffic. Traffic avoidance maneuvers are based upon Traffic Resolution Advisories, ATC guidance, or positive visual acquisition of conflicting traffic.



NOTE: Only visual annunciations will be provided on the MFI for traffic alerts. For information on traffic voice alerts, see the pertinent flight manual for each configured traffic system.

Collision avoidance and traffic surveillance data may be displayed on the 'Traffic' Page or overlaid on navigation maps. Synthetic vision traffic may also be displayed on the 'ADI' Page when SVT is configured.

The availability of functions, alerting features, and options depend on the traffic source configuration. The following traffic source configurations are allowed:

| Traffic Source | Description |
|-----------------------------|--|
| TIS | Traffic Information Service (TIS) - Traffic information uplinked from ground-based station to Mode S transponder. |
| Datalink (ADS-B / TIS-B) | Automatic Dependent Surveillance-Broadcast (ADS-B) Traffic Information Service-Broadcast (TIS-B) - Traffic information received using compatible equipment for ADS-B or TIS-B |
| TAS TCAS | Traffic Advisory System (TAS) Traffic Alert and Collision Avoidance System (TCAS) - Traffic information, interrogated from transponder-equipped aircraft, is sent to the compatible equipment system - Higher range allowed with TCAS |

Traffic Source Descriptions

DISPLAY OF TRAFFIC INFORMATION

Traffic information can be displayed on various pages. For more information on traffic overlay options on map pages, and which unit configurations offer map pages, see the Map Options discussion in the Navigation Section. For more information on displaying SVT-Traffic, see the Additional Features section.

When traffic is detected, a 'TFC' annunciation will be displayed on each page. If configured as a Standby ADI or an MFD, the 'Traffic' Page will be available. The 'Traffic' Page is the principal page for viewing traffic information. Traffic data in relation to the aircraft's current position and altitude can be displayed. Orientation on this page is always heading up unless there is no valid heading. The range may be adjusted by selecting the Range Button and using the Small Knob to zoom in or out.

Traffic source and mode information will be displayed on the outer edge of the display on the 'Traffic' Page. The following table lists the different information fields that can be displayed.

| Traffic Source | Information Displayed on the 'Traffic' Page |
|----------------|--|
| TIS-A | <ul style="list-style-type: none"> - Traffic annunciations - Orientation - Range setting |
| ADS-B TIS-B | <ul style="list-style-type: none"> - Traffic Information Banner - Altitude Filter setting - ADS-B Application Information - Other Traffic Source mode (If configured) - Traffic motion information - Orientation - Range Setting - Target Selection Button |
| TAS TCAS | <ul style="list-style-type: none"> - Traffic Information Banner - Altitude Filter setting - ADS-B Status (If configured) - Traffic Source mode - Traffic motion information - Orientation - Range setting - Target Selection Button |

'Traffic' Page Information

- System Overview
- Flight Instruments
- EIS
- Navigation
- Hazard Avoidance
- Autopilot
- WSI
- Additional Features
- Appendices
- Index

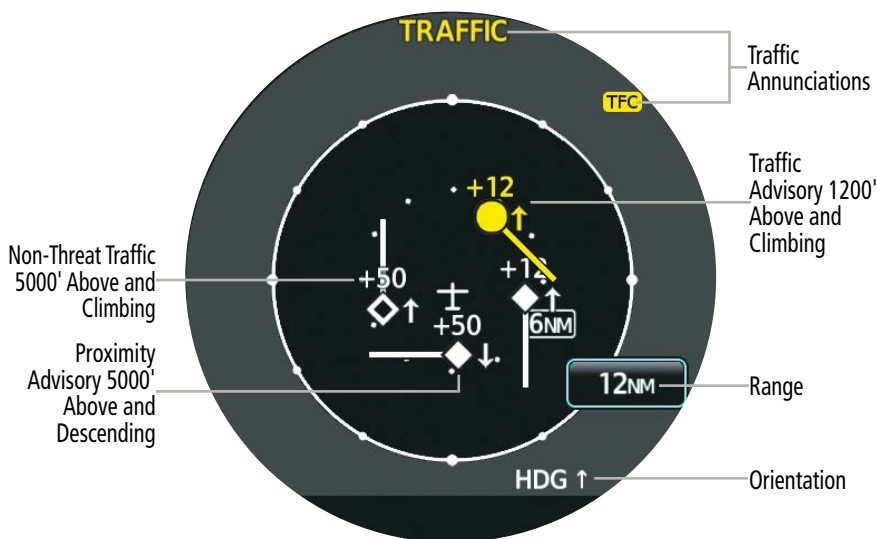

'Traffic' Page - TIS-A

Altitude Filtering

The pilot can select the volume of airspace in which non-threat and proximity traffic is displayed. Below is a list of the different altitude settings available for filtering. Altitude filtering is not available if TIS-A is the only traffic source configured.

Normal: Displays non-threat and proximity traffic from 2700 feet above the aircraft to 2700 feet below the aircraft; typically used during enroute phase of flight

Above: Displays non-threat and proximity traffic from 9000 feet above the aircraft to 2700 feet below the aircraft; typically used during climb phase of flight

Below: Displays non-threat and proximity traffic from 2700 feet above the aircraft to 9000 feet below the aircraft; typically used during descent phase of flight

Unrestricted: All traffic is displayed 9900 feet above to 9900 feet below the aircraft

Changing the altitude range:

- 1) Primary HSI Configuration: From the 'HSI Map' Page, open the menu and select **Traffic Opts > Altitude Filter**.

Or:

Standby ADI or MFD Configurations: From the 'Traffic' Page, open the menu and select **Traffic Options > Altitude Filter**.

- 2) Select the desired Altitude Setting Button.

Target Selection

Information for each traffic target may be displayed on the 'Traffic' Page (with ADS-B traffic source configured). More information on ADS-B traffic is discussed later in this section.



Selected Target - 'Traffic' Page - TCAS

Viewing traffic target information:

Touch the desired target symbol on the 'Traffic' Page. Information about the selected target is displayed in the information banner.

Traffic Overlay on Maps

Traffic information may also be displayed as map overlays and serve as additional reference to the 'Traffic' Page. When traffic is selected on maps other than the 'Traffic' Page, a traffic status icon is shown to indicate the feature is enabled for display. For more information on map overlay options, see the Map Options portion of the Navigation Section.

| System Status | Traffic Icon |
|---------------------------|--------------|
| Operating | |
| No Traffic Data Available | |

Traffic Status Icon on Map Displays

Traffic Alerts - Primary ADI and Primary HSI

A Traffic Alert (TA) may be issued anytime there is an increase in the number of traffic advisories. Traffic advisory parameters and alerts depend on the traffic source configuration in use. When a traffic alert condition is detected, a 'TFC' annunciation will be displayed on each page. This annunciation will flash for five seconds before being displayed steady until the threat is cleared.

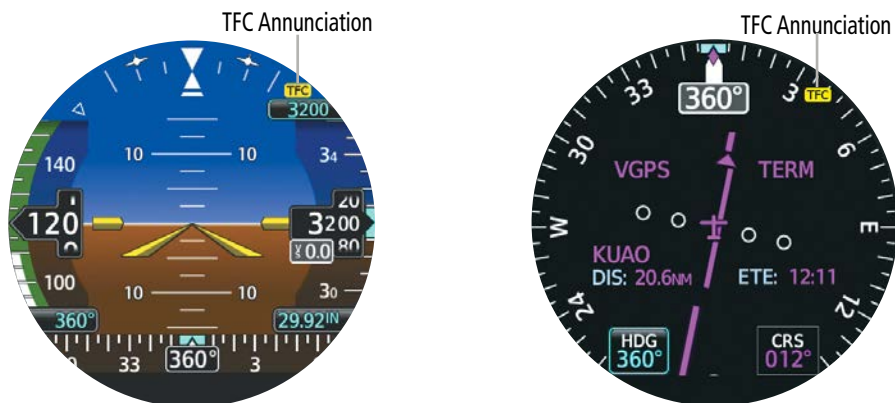

Primary ADI and Primary HSI Traffic Alert Examples

Traffic Alerts - Standby ADI, and Standby MFD

A Traffic Alert (TA) may be issued anytime there is an increase in the number of traffic advisories. Traffic advisory parameters and alerts depend on the traffic source configuration in use.

When an alert is issued, a 'TRAFFIC' annunciation will appear on the 'Traffic' Page, or as a pop-up alert, and a 'TFC' annunciation will be displayed on every page. To acknowledge a traffic pop-up alert:

- Touch the **Close** Button (returns to the currently viewed page), or

- Touch the **Go to Traffic** Button (accesses the 'Traffic' Page).

- System Overview
- Flight Instruments
- EIS
- Navigation
- Hazard Avoidance**
- Autopilot
- WSI
- Additional Features
- Appendices
- Index

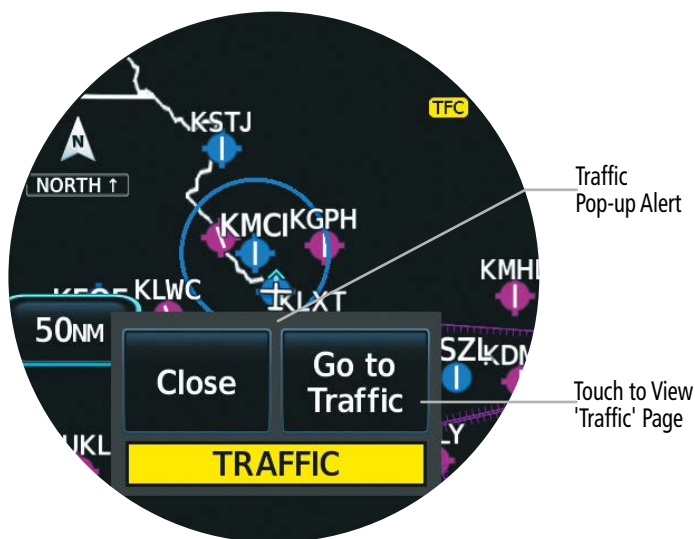

Traffic Pop-up Alert - 'Map' Page

'TRAFFIC' PAGE ADVISORIES

Traffic Advisory information is provided on the 'Traffic' Page. See the following table for a list of the different kinds of information and advisories which can be shown.

| Displayed | Description |
|----------------------|--|
| TRAFFIC | A Traffic Advisory is displayed within the selected range. |
| TA X.X +/- XX | System cannot determine bearing of Traffic Advisory. Annunciation indicates distance in nm, altitude separation in hundreds of feet, and altitude trend arrow (climbing/descending). |
| AGE MM:SS | Appears if traffic data is not refreshed within 6 seconds. If after another 6 seconds data is not received, traffic is removed from the display. The quality of displayed traffic information is reduced as the age increases. |
| TRFC COAST | The displayed data is not current (6 to 12 seconds since last message). The quality of displayed traffic information is reduced when this message is displayed. |
| TRFC RMVD | Traffic is removed because it is too old for coasting (12 to 60 seconds since last message). Traffic may exist within the selected display range, but it is not displayed. |
| TRFC FAIL | Traffic data has failed. |

| Displayed | Description |
|---------------------|---|
| TRFC UNAVAIL | The traffic service is unavailable or out of range. |

Traffic Advisory Information - 'Traffic' Page

If the traffic source fails, information as to the cause of the failure is shown in the center of the 'Traffic' Page. During a failure condition, the Operating Mode cannot be selected.

| Displayed | Description |
|----------------|---|
| NO DATA | Data is not being received from the traffic unit* |
| FAILED | The traffic unit has failed* |
| UNAVAIL | Traffic service is unavailable or out of range |
| STBY | Traffic function is in Standby Mode |

* Contact a service center or Garmin dealer for corrective action.

Traffic Failure Annunciations

TRAFFIC DATA BY SOURCE

Traffic Information Service (TIS)





NOTE: TIS-A is available only when the aircraft is within the service volume of a TIS-capable terminal radar site. TIS-B is available when the aircraft is within the service volume of an ADS-B ground station. Aircraft without an operating transponder are invisible to Traffic Advisory Systems (TAS), Traffic Alert and Collision Avoidance Systems (TCAS) and TIS. Aircraft without altitude reporting capability are shown without altitude separation data or climb descent indication.



NOTE: TIS-A is disabled if another traffic system is installed. TIS-B, a component of ADS-B traffic, can be used in conjunction with TCAS and TAS.

Traffic Information Service (TIS) is designed to help in detection and avoidance of other aircraft. TIS uses the Mode S transponder for the traffic datalink. TIS receives traffic information from ground stations and is updated every 5 seconds. The system displays up to eight traffic targets within a 7.5-nm radius, from 3000 feet below to 3500 feet above the requesting aircraft. Traffic is displayed using the symbols shown in the table below.

| TIS Symbol | Description |
|---|----------------------------|
|  | Non-Threat Traffic |
|  | Traffic Advisory (TA) |
|  | Traffic Advisory Off Scale |

TIS Traffic Symbols

A Traffic Advisory (TA) indicates the current track of the intruder could result in a collision. When traffic meets the advisory criteria for the TA, a solid yellow circle symbol is generated. A TA which is detected, but is outside the range of the map, is indicated on the outer ring of the traffic map by a half TA symbol at the relative bearing of the intruder.

Traffic information for which TIS is unable to determine the bearing (non-bearing traffic) is displayed in the center of the 'Traffic' Page or as a symbol at the bottom of maps other than the 'Traffic' Page on which traffic can be displayed.

The altitude difference between the requesting aircraft and other intruder aircraft is displayed above/below the traffic symbol in hundreds of feet. If the other aircraft is above the requesting aircraft, the altitude separation appears above the traffic symbol; if below, the altitude separation appears below. Altitude trend is displayed as an up/down arrow (for speeds greater than 500 fpm in either direction) to the right of the target symbol. Traffic symbols for aircraft without altitude reporting capability appear without altitude separation or climb/descent information.

- System Overview
- Flight Instruments
- EIS
- Navigation
- Hazard Avoidance
- Autopilot
- WSI
- Additional Features
- Appendices
- Index

TIS ALERTS

When the number of TAs on the 'Traffic' Page increases from one scan to the next, a 'TRAFFIC' annunciation will appear on the 'Traffic' Page, or as a pop-up alert.

To reduce the number of nuisance alerts due to proximate aircraft, the 'TRAFFIC' alert annunciation is generated only when the number of TAs increases. For example, when the first TA is displayed, an annunciation is generated. As long as a single TA remains on the display, no additional alerts are generated. If a second TA appears on the display or if the number of TAs initially decreases and then subsequently increases, another alert is generated.

The annunciation 'UNAVAILABLE' is generated when the TIS service becomes unavailable or is out of range. TIS may be unavailable in the radar coverage area due to the following:

- Radar site TIS Mode S sensor is not operational or is out of service
- Traffic or requesting aircraft is beyond the maximum range of the TIS-capable Mode S radar site
- Traffic or requesting aircraft is above the radar site in the cone of silence and out of range of an adjacent site
- Traffic or requesting aircraft is below radar coverage; in flat terrain, the coverage extends from about 3000 feet upward at 55 miles; terrain and obstacles around the radar site can further decrease radar coverage in all directions
- Traffic does not have an operating transponder

TIS SYSTEM STATUS

The system performs an automatic test of TIS when power is applied to the system. If TIS passes the test, TIS enters Standby Mode (on the ground) or Operating Mode (in the air). If TIS fails the test after power is applied to the system, an annunciation is shown in the center of the 'Traffic' Page.

When the aircraft is on the ground, TIS automatically enters Standby Mode. STBY will be annunciated on the 'Traffic' Page. Also, the Traffic Status Icon on other maps will be crossed out (also the case whenever TIS has failed).

Once the aircraft is airborne, TIS switches to Operating Mode and traffic information is displayed. The mode can be changed manually by using the page menu.

Manually switching between TIS modes:

- 1) From the 'Traffic' Page, open the page menu and select **Traffic Options**.
- 2) Select the **Traffic Status** Button to toggle between 'Standby' or 'Operate' modes.

Datalink Traffic



WARNING: Do not rely solely upon the display of traffic information to accurately depict all of the traffic information within range of the aircraft. Due to lack of equipment, poor signal reception, and/or inaccurate information from other aircraft, traffic may be present but not represented on the display.



NOTE: If equipped, ADS-B Traffic can be shared with certain Bluetooth connected devices. Refer to System Overview Section for Bluetooth pairing instructions.

Automatic Dependent Surveillance-Broadcast (ADS-B) is a core technology in the FAA NextGen air traffic control system. It offers improved surveillance services, both air-to-air and air-to-ground, especially in areas where radar coverage is ineffective due to terrain, or where it is impractical or cost prohibitive. ADS-B is comprised of three segments for the purposes of providing traffic information: ADS-B (Broadcast), ADS-R (Rebroadcast), and Traffic Information Service-Broadcast (TIS-B).

ADS-B includes the automatic broadcast of position reports by aircraft, surface vehicles, and transmitters on fixed objects. These broadcasts contain information such as GPS position, identity (Flight ID, Call Sign, Tail Number, ICAO registration number, etc.), ground track, ground speed, pressure altitude, and emergency status.

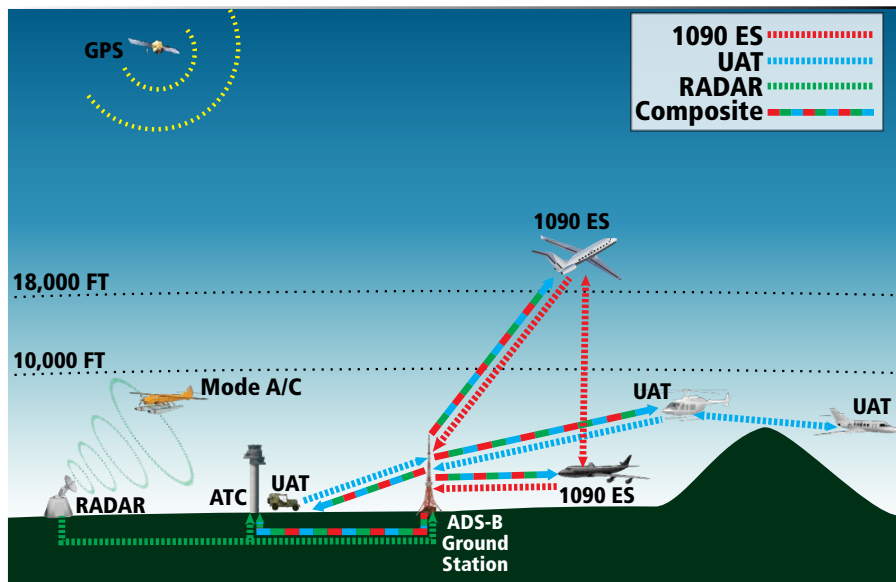

ADS-B System

For the purpose of distinguishing between levels of ADS-B service, there are three classifications of aircraft or system capability:

ADS-B In - capability to receive ADS-B information,

ADS-B Out - capability to transmit ADS-B information, and

ADS-B Participating - capability to both send and receive ADS-B information.

Aircraft lacking either ADS-In, ADS-B Out, or both ADS-B capabilities may also be referred to as ADS-B nonparticipating aircraft.

The ADS-B system operates on two frequencies: 1090 MHz and 978 MHz. Both frequencies provide the same traffic information. An aircraft may be ADS-B In, Out, or participating on one or both frequencies, depending on the installed equipment. The 1090 MHz frequency portion of ADS-B is known as 1090 Extended Squitter (1090 ES). The 978 MHz portion of ADS-B is known as Universal Access Transceiver (UAT).

Because it is not required that ADS-B In capable aircraft be able to receive ADS-B data on both the 1090 MHz and 978 MHz datalinks, a method exists to get data from one datalink to the other. ADS-R is the rebroadcast of ADS-B data by FAA ground stations, which provide this service by taking traffic data from one link and rebroadcasting it on the other. For example, if two aircraft are in the service volume for a ground station, and one is transmitting on 1090 MHz and the other is transmitting on 978 MHz, the ground station retransmits the data from each aircraft on the other link to ensure the two aircraft can “see” each other as traffic.

For example, if another aircraft can only receive 978 MHz UAT information, it cannot directly ‘see’ another aircraft sending only 1090 ES information aircraft unless an ADS-R ground station in the vicinity rebroadcasts the 1090 ES data over the 978 MHz UAT frequency. This is also true for an aircraft that can only receive 1090 ES data; it would need an ADS-R ground station to ‘see’ another aircraft operating on the UAT frequency.

TIS-B (Traffic Information Service-Broadcast) provides a link between the secondary surveillance radar (SSR)-based system ATC uses and the ADS-B-based system. When an ADS-B Out capable aircraft is within the service volume of an FAA ADS-B ground station, the ground station broadcasts a portion of the ATC radar data to the aircraft. This aircraft is then included in the list of aircraft being provided TIS-B service and is then considered a “TIS-B participant.”

TIS-B coverage is available when the aircraft is within ground station coverage, in SSR coverage, and the other aircraft is also in SSR coverage, and is transmitting its altitude. The ground station provides ATC radar information for other aircraft within $\pm 3,500$ feet and 15 NM of the participant, to include altitude, position, ground speed, and ground track. TIS-B broadcasts occur once every three to thirteen seconds, depending on the characteristics of the ground station providing the TIS-B service. The symbols used to display ADS-B traffic are shown in the following table. Above or below the traffic symbol is the traffic identifier, and altitude. A small up or down arrow next to the traffic symbol indicates that traffic is climbing or descending at a rate of at least 500 feet per minute.

| Symbol | Description |
|--------|--|
| | Traffic Advisory with directional information. Points in the direction of the intruder aircraft track. |
| | Traffic Advisory without directional information. |
| | Target belongs to a group; when grouped, the most immediate threat is the target displayed. |
| | Traffic Advisory out of the selected display range with directional information. Displayed at outer range ring at proper bearing. |
| | Traffic Advisory out of the selected display range without directional information. Displayed at outer range ring at proper bearing. |
| | Proximity Advisory with directional information. Points in the direction of the aircraft track. |
| | Proximity Advisory without directional information. |
| | Other Non-Threat traffic with directional information. Points in the direction of the intruder aircraft track. |
| | Other Non-Threat traffic without directional information. |
| | Traffic located on the ground with directional information. Points in the direction of the aircraft track. Ground traffic is only displayed when the Surface (SURF) application is active, or own aircraft is on the ground. |
| | Ground traffic without directional information. Ground traffic is only displayed when the Surface (SURF) application is active, or own aircraft is on the ground. |
| | Non-aircraft ground traffic. Ground traffic is only displayed when the Surface (SURF) application is active, or own aircraft is on the ground. |

ADS-B Traffic Symbology

System Overview
Flight Instruments
EIS
Navigation
Hazard Avoidance
Autopilot
WSI
Additional Features
Appendices
Index

The display settings (motion and duration) for motion vectors may be accessed through the traffic options menu. The display of motion vectors may also be turned off.

Changing motion vector display settings:

- 1) From the 'Traffic' Page, open the page menu and select **Traffic Options**.
- 2) Select either the **Motion Vector** Button or the **Vector Duration** Button to display more settings.
- 3) Select the desired display setting button. The setting is now shown on the 'Traffic Opts' Menu.
- 4) Repeat Steps 2-3 as necessary to change the motion vector display settings.

Traffic within close proximity of each other may be displayed as a group. The asterisk indicates the target displayed belongs to a group, and the most immediate threat is the target displayed. Traffic grouping may be enabled or disabled as desired.

Enabling/disabling traffic grouping:

- 1) Primary HSI Configuration: From the 'HSI Map' Page, open the menu and select **Traffic Opts**.
Or:
Standby ADI or MFD Configurations: From the 'Traffic' Page, open the menu and select **Traffic Options**.
- 2) Select the **Traffic Grouping** Button to enable or disable the function.

ADS-B ALERTS

The MFI uses an alerting algorithm to issue ADS-B traffic alerts (TA). The own aircraft altitude above terrain determines the sensitivity of the alerting algorithm to minimize nuisance alerts. Height Above Terrain, and Geodetic Sea Level (GSL) altitude are used to adjust the sensitivity of the algorithm.

A 'TRAFFIC' annunciation will appear on the 'Traffic' Page, or as a pop-up alert when a TA is issued.

If the bearing of TA traffic cannot be determined, a yellow text banner will be displayed in the center of the 'Traffic' Page instead of a TA symbol. The text will indicate 'TA' followed by the distance, relative altitude, and vertical trend arrow for the TA traffic, if known.

A TA will be displayed for at least eight seconds, even if the condition(s) that initially triggered the TA are no longer a factor.

ADS-B APPLICATIONS

ADS-B traffic can help the pilot visually acquire traffic both in the air and on-the-ground. There are three ADS-B applications supported by the MFI: Airborne Situational Awareness (AIRB) and Surface Situational Awareness (SURF) and ADS-B Traffic Advisory System (ATAS). AIRB is considered the fundamental airborne traffic application. ATAS provides alerts when airborne traffic trajectories pose a potential collision risk. SURF provides additional situational awareness when on ground or within the terminal environment. The system automatically selects the appropriate application based on conditions.

Due to the varying precision of the data received through ADS-B, ADS-R, and TIS-B services, not all traffic symbols may be depicted on the traffic display. Because higher data precision is required for traffic to be displayed in the SURF environment, some traffic eligible for AIRB will not be displayed while SURF is on.

Disabling the display of ADS-B applications:

- 1) From the 'Traffic' Page, open the page menu and select **Traffic Options**.
- 2) Select the **ADS-B Display** Button to toggle between the active application and 'Off'.

ADS-B SYSTEM STATUS

The traffic source and status is annunciated on the 'Traffic' Page. During normal operation, the "ADS: On" status means that both AIRB and ATAS applications are active.

A test of the traffic system may be initiated, which will display a test pattern on the 'Traffic' Page. Then, the system returns to normal operation once the test is complete.

Manually initiating system test for the configured traffic source:

- 1) From the 'Traffic' Page, open the page menu and select **Traffic Options**.
- 2) Select the **Test** Button. A system test is initiated and 'TEST' is displayed next to the Traffic Source on the 'Traffic' Page.

Traffic information is provided in the information banner at the top of the 'Traffic' Page. Traffic information is dependent on the traffic source configuration.

The following lists the various kinds of data which can be displayed on the 'Traffic' Page:

- Registration / call sign
- Vehicle type
- Closure Rate
- Track
- Ground Speed



'Traffic' Page - ADS-B

TAS/TCAS Traffic



WARNING: Do not rely solely upon the display of traffic information to accurately depict all of the traffic information within range of the aircraft. Due to lack of equipment, poor signal reception, and/or inaccurate information from other aircraft, traffic may be present but not represented on the display.



NOTE: Pilots should be aware of TAS/TCAS I system limitations. TAS/TCAS I systems require transponders of other aircraft to respond to system interrogations. If the transponders do not respond to interrogations due to phenomena such as antenna shading or marginal transponder performance, traffic may be displayed intermittently, or not at all. Aircraft without altitude reporting capability are shown without altitude separation data or climb descent indication. Pilots should remain vigilant for traffic at all times.







NOTE: TIS is disabled when TAS or TCAS I is installed.

A compatible Traffic Advisory System (TAS) or Traffic Alert and Collision Avoidance System (TCAS I) may be configured for use. Differences between these traffic systems will be noted where applicable throughout this section. TAS and TCAS enhance flight crew situational awareness by displaying traffic information for transponder-equipped aircraft, while also providing visual annunciations and alerts to assist the pilot in visually acquiring traffic.

When the traffic system is in Operating Mode, the system interrogates the transponders of aircraft in the vicinity while monitoring transponder replies. The system uses this information to derive the distance, relative bearing, and if reported, the altitude and vertical trend for each aircraft within its surveillance range. The traffic system then calculates a closure rate to each intruder based on the projected Closest Point of Approach (CPA). If the closure rate meets the threat criteria for a Traffic Advisory (TA), the system displays visual annunciations.

The traffic surveillance system monitors the airspace within $\pm 10,000$ feet of own altitude. Surveillance range is dependent upon the configured traffic system. In areas of greater transponder traffic density or when TCAS systems are detected, the on-board traffic system automatically reduces its interrogation transmitter power (and therefore range) in order to limit potential interference from other signals.

The symbols used to display TAS / TCAS traffic are shown in the following table.

| Traffic Symbol | Description |
|---|--|
|  | Non-Threat Traffic - Traffic is beyond 6 nm and is neither a TA or PA. |
|  | Proximity Advisory (PA) - Indicates the intruding aircraft is within ± 1200 feet and is within a 6 nm range |
|  | Traffic Advisory (TA) - Potentially hazardous intruding aircraft meets the closing rate, distance, and vertical separation parameters for TA criteria |
|  | Traffic Advisory Off Scale |

Traffic Symbol Description

Relative altitude, when available, is displayed above or below the corresponding intruder symbol in hundreds of feet. When this altitude is above own aircraft, it is preceded by a '+' symbol; a minus sign '-' indicates traffic is below own aircraft.

The system displays the altitude vertical trend as an up/down arrow (for speeds vertical greater than 500 fpm in either direction) to the right of the intruder symbol.



Intruder Altitude and Vertical Trend Arrow

The traffic system automatically suppresses the display of altitude-reporting aircraft on the ground under either of the following conditions:

- On-ground aircraft is equipped with a Mode S transponder

- On-ground aircraft is equipped with a Mode C transponder

TRAFFIC ADVISORY ALERTS (TAS / TCAS)

The traffic system automatically adjusts its TA sensitivity level to reduce the likelihood of nuisance TA alerting in certain conditions. If a radar altimeter is installed, the system applies Level A (less) sensitivity when the aircraft is below 2000' AGL. If a radar altimeter is not installed, the system applies Level A sensitivity when the groundspeed is less than 120 knots.

| Sensitivity Level | Intruder Altitude Available | TA Alerting Conditions |
|-------------------|-----------------------------|--|
| A | Yes | Intruder closing rate provides less than 20 seconds of vertical and horizontal separation. Or: Intruder closing rate provides less than 20 seconds of horizontal separation and vertical separation is within 600 feet. Or: Intruder range is within 0.2 nm and vertical separation is within 600 feet. |
| A | No | Intruder closing rate provides less than 15 seconds of separation. |
| B | Yes | Intruder closing rate provides less than 30 seconds of vertical and horizontal separation. Or: Intruder closing rate provides less than 30 seconds of horizontal separation and vertical separation is within 800 feet. Or: Intruder range is within 0.55 nm and vertical separation is within 800 feet. |
| B | No | Intruder range is less than 20 seconds. |

TA Sensitivity Level and TA Alerting Criteria

A 'TRAFFIC' annunciation will appear on the 'Traffic' Page, or as a pop-up alert when a TA is issued. A TA will be displayed for at least eight seconds, even if the condition(s) that initially triggered the TA are no longer present.

TAS / TCAS SYSTEM STATUS



NOTE: *Traffic surveillance is not available during the system test. Use caution when performing a system test during flight.*

The traffic system provides a system test mode to ensure the system is operating normally. The test takes ten seconds to complete. When the system test is initiated, a test pattern of traffic symbols appears on the 'Traffic' Page.

When the system test is complete, the traffic system enters Standby Mode. Standby mode will be indicated white in the center of the 'Traffic' Page. Otherwise, the status of the traffic system will be indicated in the Traffic Source field on the 'Traffic' Page.

Manually initiating system test for the configured traffic source:

- 1) From the 'Traffic' Page, open the page menu and select **Traffic Options**.
- 2) Select the Test Button. A system test is initiated and 'TEST' is displayed next to the Traffic Source on the 'Traffic' Page.

SECTION 6 AUTOPILOT

6.1 OVERVIEW



WARNING: Do not rely on the Autopilot to level the aircraft at the minimum approach altitude when flying an approach with vertical guidance.



NOTE: Fixed Wing configurations only.



NOTE: Refer to the applicable Flight Director / AFCS Controller Manual for further information on how to operate an external Flight Director / AFCS Controller, if configured.

The GI 275 Multi-Function Instrument (MFI) receives and analyzes inputs from an external Flight Director, which in turn provides pitch, roll, and yaw gyro outputs to an Autopilot. The Autopilot operates the flight control servos which provides automatic flight control.

The MFI is capable of providing Yaw Damper control. The Yaw Damper reduces Dutch Roll tendencies and coordinates turns. It can operate independent of the Autopilot and may be used during normal hand-flown maneuvers. Yaw rate commands are limited by the Yaw Damper.



NOTE: An external Flight Director / AFCS Controller is required to fully operate the Autopilot capabilities of the MFI.

To utilize the Autopilot functionality, the following hardware is required:

- GI 275-20 (Basic with ADAHRS and Autopilot Interface)
- GMU 11 Magnetometer or GMU 44B (if applicable)
- Flight Director (if applicable)
- AFCS Controller (if applicable)

The MFI is also capable of displaying Flight Director information when connected to an external Flight Director. If configured, the following functions are provided:

- The capability to have GPS 1/2 and NAV 1/2 inputs for source selection from a navigation system and output signals for NAV and GPSS steering
- The capability to capture vertical navigation (e.g., glideslope, glidepath)
- The capability to provide CDI/VDI preview if a GTN (GPS/NAV/COM/MFD) is installed

6.2 FLIGHT CONTROL

Pitch and roll commands are provided for control of the servos based on the active Flight Director modes. Yaw damping is provided by the yaw servo. Servo motor control limits the maximum servo speed and torque. The servo gearboxes allow the servos to be overridden in case of an emergency.

PITCH AXIS AND TRIM

The Autopilot pitch axis uses pitch rate to stabilize the aircraft pitch attitude during upsets and Flight Director maneuvers. Flight Director pitch commands are rate and attitude-limited, combined with pitch damper control, and sent to the pitch servo motor.

When the Autopilot is engaged, the Automatic Pitch Trim (APT) function commands the pitch trim actuator to reduce the average pitch servo effort.

When the Autopilot is not engaged, manual trim functionality is available at any time by using the **Trim** Switches.

ROLL AXIS

The Autopilot roll axis uses roll rate to stabilize aircraft roll attitude during upsets and Flight Director maneuvers. The Flight Director roll commands are rate and attitude-limited, combined with roll damper control, and sent to the roll servo motor.

YAW AXIS

The Autopilot yaw axis uses yaw rate and roll attitude to dampen the aircraft's natural Dutch roll response. The Yaw Damper uses lateral acceleration to coordinate turns.

6.3 AUTOPILOT OPERATION

COMMAND BARS

Upon activation of a Flight Director, Command Bars are displayed in magenta on the MFI as a single cue. The Command Bars move vertically to indicate pitch commands and bank left or right to indicate roll commands.

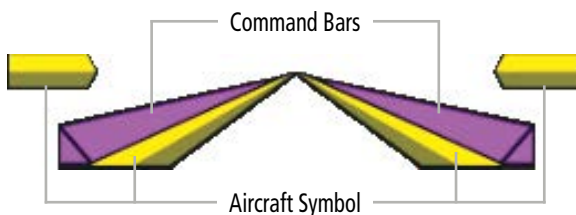

Single-Cue Command Bars

When the Autopilot is engaged, the magenta Command Bars and the yellow Aircraft Symbol move together in unison.

If the aircraft is flown by hand (e.g., using external Control Wheel Steering), the yellow Aircraft Symbol changes to indicate aircraft attitude while the magenta Command Bars do not change (indicating no change to Flight Director cueing).

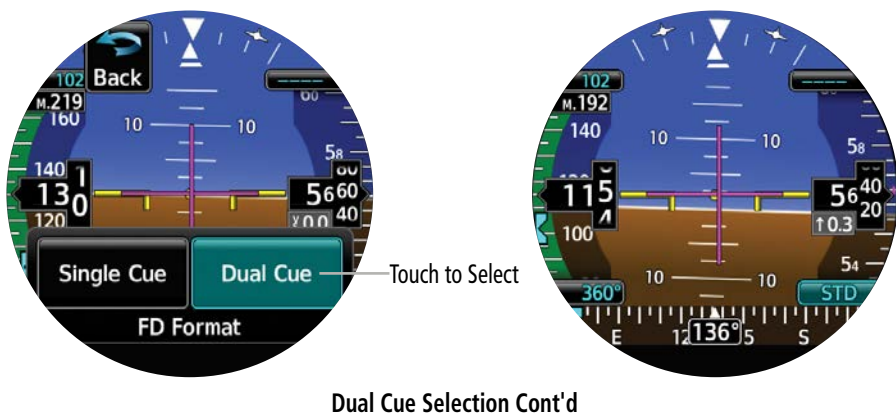
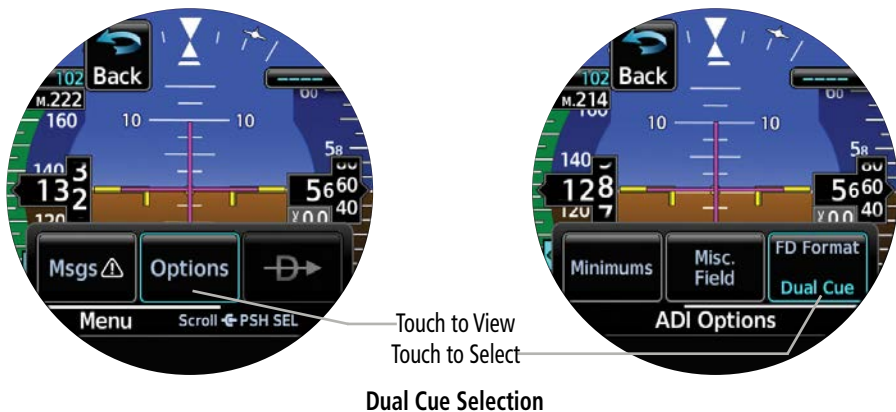

ENGAGING THE AUTOPILOT

When the Autopilot is engaged (via an external controller), the Autopilot is activated on the MFI and is indicated by the magenta Command Bars and the yellow Aircraft Symbol moving together in unison. Engagement is also observed by indications on your external Flight Director or external controller.

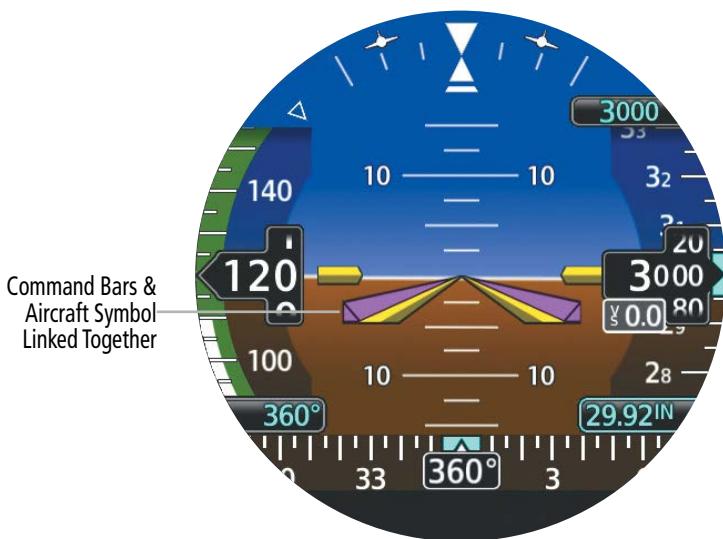

Autopilot Engaged

DISENGAGING THE AUTOPILOT

Manual Disengagement

The Autopilot is manually disengaged from the external Flight Director / AFCS Controller by using the **A/P DISC** Switch. For both Single-Cue and Dual-Cue Command Bars, disengaging the Autopilot results in hollow Command Bars (Flight Director). The Flight Director is disengaged separately.

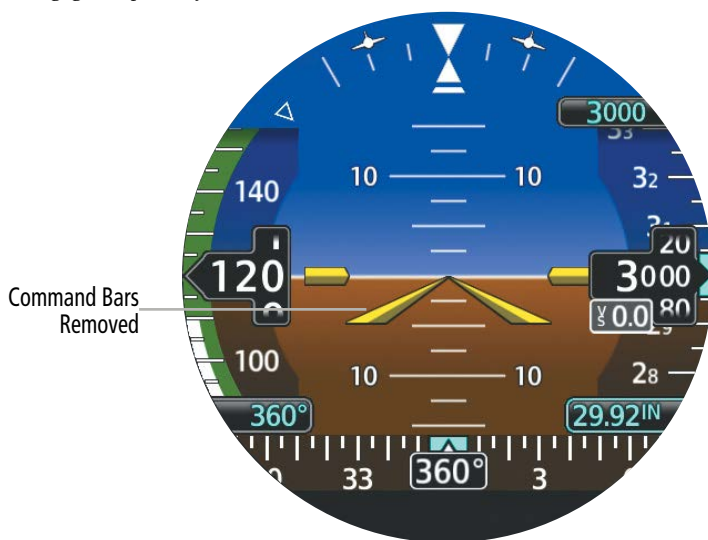

Manual Autopilot Disengagement

Automatic Disengagement

Automatic Autopilot disengagement may occur due to:

- System failure (e.g., loss of ADC and GPS).

- Invalid sensor data (e.g., sensor mis-compare or non-compare).



NOTE: During system startup if the Autopilot is engaged (though not typical), the MFI will automatically disengage the Autopilot when the sensors initiate alignment.



NOTE: In the event of an in-flight restart, the Autopilot may disengage.

Discrete Configurations

The MFI can be configured to have airspeed discrete inputs tied to Autopilot. Activation of a discrete may be configured to automatically disengage the Autopilot given your external hardware.

6.4 GARMIN GFC 500 AUTOPILOT (OPTIONAL)



NOTE: The approved aircraft documentation always supersedes the information in this Pilot's Guide.



NOTE: Refer to the approved aircraft documentation for emergency procedures.



NOTE: A GMC 507 controller is required for GFC 500 AFCS functionality.

GFC 500 AFCS CONFIGURATION

The following figure provides an overview of the GFC 500 system:



In addition to the core autopilot functions, the GFC 500 incorporates an independent monitor that uses inertial sensors to determine what is happening to the aircraft. By monitoring aircraft attitude, attitude rate and accelerations using these independent sensors, the monitor can shut down the autopilot if it determines the aircraft has exceeded predetermined limits.

The minimum configuration for the GFC 500 system is a GI 275 configured as an Attitude Indicator and two GSA 28 servos (in the pitch and roll positions). This will provide Pitch, Roll, Track, and Air Data modes only.

If navigation modes are desired, a GI 275 connected to a compatible navigation source (e.g., a GTN 6XX/7XX) is an option.

The basic GFC 500 system is comprised of the following equipment:

GMC 507 MODE CONTROLLER

The panel-mounted GMC 507 serves as the primary user interface for the GFC 500. The GMC 507 provides autopilot and flight director mode selection keys and a wheel for convenient adjustment of the pitch, airspeed, and vertical speed references. The GI 275 MFI Page displays active and armed modes and reference values.



GMC 507

GSA 28 SERVO

The GSA 28 servos provide control surface actuation as part of the autopilot, yaw damper, electric trim, and ESP functions. The GSA 28 is a 'smart' servo which performs most of the autopilot processing functions and offers many inherent safety features. The brushless motor and electronic torque and speed sensing capabilities provide smooth, reliable operation. The GSA 28 design incorporates an internal engagement solenoid and a gear train that allows the motor to be backdriven by the pilot in case the solenoid fails to disengage. This eliminates the need for a mechanical slip clutch along with the associated performance limitations and maintenance requirements.



GSA 28

6.5 AFCS SYSTEM ARCHITECTURE

An Automatic Flight Control System (AFCS) is typically comprised of two major components: A flight director (FD) and autopilot servos. The flight director provides pitch and roll commands to the autopilot servos. These pitch and roll commands are displayed on the PFD Page as Command Bars. When the flight director is active the pitch and roll commands can be hand-flown by the pilot or when coupled with the autopilot, the autopilot servos drive the flight controls to follow the commands issued by the flight director. The flight director operates independently of the autopilot servos, but in most cases the autopilot servos can not operate independent of the flight director.

GI 275 AFCS STATUS BOX



The AFCS status box displays autopilot (AP) and flight director (FD) mode annunciations on the ADI Page.

Autopilot (AP) status is displayed middle of the GI 275 Autopilot Status Box. Lateral modes are displayed on the left, and vertical modes are displayed on the right. Armed modes are displayed in white and active in green.

AFCS OPERATION

The Automatic Flight Control System (AFCS) provides the following main operating functions:

- **Flight Director (FD)** - The flight director function provides pitch and roll commands needed to guide the aircraft toward the active reference selected by the pilot. These pitch and rolls commands are displayed on the GI 275 ADI Page as Command Bars. When the flight director is active the pitch and roll commands can be hand-flown by the pilot. When the autopilot is engaged the autopilot servos drive the flight controls to follow the commands issued by the flight director.
- **Autopilot (AP)** - The autopilot function is provided by servo actuators which move the flight control surfaces in response to flight director steering commands, aircraft attitude, and airspeed. The optional pitch auto-trim function serves to relieve any sustained effort required by the pitch servo to keep the aircraft in trim.
- **Yaw Damper (YD)** - The optional Yaw Damper function provides Dutch Roll damping, assists in turn coordination, and provides a steady force to help maintain directional trim. If installed the YD comes on when the autopilot is engaged. It can be turned on/off independent of the autopilot and may be used during normal hand-flying maneuvers.
- **Manual Electric Trim (MET)** - The optional Manual Electric Trim uses the same servo as the auto-trim function and allows the pilot to command trim via a trim switch when the autopilot is not engaged. The MET function does not preclude the use of the aircraft's basic mechanical trim system.

- Electronic Stability & Protection (ESP) (GFC 500)** - The ESP function provides a soft barrier to keep the aircraft within the desired operating envelope when the autopilot is not engaged. When the AFCS senses the aircraft is near the defined operating limit in pitch attitude, roll attitude, high airspeed, or low airspeed, the ESP function will automatically engage one or more servos to nudge it back to the nominal operating envelope. While ESP utilizes the same sensors, processors, and actuators as the AFCS autopilot, it is a separate, mutually exclusive function. ESP can be easily overpowered by the pilot and can be disabled using the **AP DISC / TRIM INT** Button.

GMC 507 CONTROLS

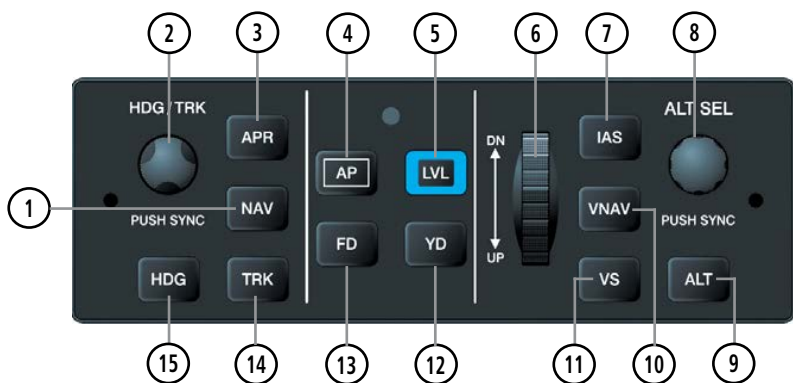

GMC 507 AFCS Control Unit

- 1 NAV Key**
 Selects/deselects Navigation Mode. Cancels GS Mode if LOC Mode is either active or armed. Cancels GP Mode if GPS Mode is either active or armed. Cancels LOC Mode if GPS Mode is active and LOC Mode is armed.
- 2 HDG/TRK Knob**
 Selects the desired Heading/Track
- 3 APR Key**
 Selects/deselects Approach Mode (GP or GS mode only)
- 4 AP Key**
 Engages/disengages the autopilot
- 5 LVL (Level) Key**
 Engages the autopilot (if the autopilot is disengaged) in level vertical and lateral modes
- 6 NOSE UP/DN Wheel**
 Adjusts the vertical mode reference in Pitch Hold, Vertical Speed, Indicated Airspeed, and Altitude Hold modes
- 7 IAS Key**
 Selects/deselects Indicated Airspeed Mode
- 8 ALT SEL Knob**
 Selects the desired Altitude setting

| | | | |
|--------------------|----|-----------------|---|
| System Overview | 9 | ALT Key | Selects/deselects Altitude Hold Mode |
| Flight Instruments | 10 | VNAV Key | Selects/deselects Vertical Path Tracking Mode for Vertical Navigation flight control |
| EIS | 11 | VS Key | Selects/deselects Vertical Speed Mode |
| Navigation | 12 | YD Key | Engages/disengages the yaw damper |
| Hazard Avoidance | 13 | FD Key | Activates/deactivates the flight director only Pressing once turns on the director in the default vertical and lateral modes. Pressing again deactivates the flight director and removes the Command Bars. If the autopilot is engaged, the key is disabled. |
| Autopilot | 14 | TRK Key | Selects/deselects Track (TRK) Mode. |
| WSI | 15 | HDG Key | Selects/deselects Heading Select Mode. (No function in installations without a magnetometer) |

The following AFCS controls are located separately from the GI 275 and GMC 507 AFCS Control Unit:

| Control | Action |
|--|--|
| AP DISC / TRIM INT (Autopilot Disconnect) | An AP DISC / TRIM INT Button is located on the pilot's control stick / yoke. Press and release the AP DISC / TRIM INT Button to disengage the autopilot. |
| Go Around Button (Takeoff / Go Around) | Selects flight director Takeoff or Go Around Mode. |
| MET Switch (Manual Electric Trim) | Used to command manual electric pitch trim. |

ENGAGING THE AUTOPILOT

Before Takeoff:

- 1) Autopilot - ENGAGE (using AP button, or AP button on mode controller)
- 2) AP DISC button - PRESS (verify autopilot disengages and audio alert is heard)
- 3) Verify yaw damper - OFF (if installed) (verify yaw damper disengages and audio alert is heard).
- 4) Flight director - SET FOR TAKEOFF (select TO or VS mode or push FD Button to turn off the Flight Director)
- 5) Flight controls - CHECK (verify autopilot servos are disengaged from pitch, roll, and yaw controls, and all controls move freely)
- 6) Elevator trim control - SET FOR TAKEOFF

Engaging The Autopilot:

An initial press of the **AP** key on the GMC 507 will activate the flight director and engage the autopilot in the default PIT and ROL modes.

DISENGAGING THE AUTOPILOT

The autopilot is manually disengaged by pressing the autopilot disconnect button on the control stick or yoke or by pressing the **AP** Key on the GMC 507. Manual disengagement is indicated by a five-second flashing yellow 'AP' annunciation. Cancel the aural alert by pressing and releasing the **AP** Key again.

In addition, the optional **MET** trim switch will disengage the autopilot.

Automatic disengagement is indicated by a flashing red 'AP' annunciation. Automatic disengagement occurs due to:

- System failure
- Invalid sensor data
- Inability to compute default autopilot modes
- Autopilot internal monitoring detects abnormal behavior

OVERPOWERING AUTOPILOT SERVOS

In the context of this discussion, “overpowering” refers to any pressure or force applied to the pitch controls when the autopilot is engaged. A small amount of pressure or force on the pitch controls can cause the autopilot automatic trim to run to an out-of-trim condition. Therefore, any application of pressure or force to the controls should be avoided when the autopilot is engaged.

Overpowering the autopilot during flight will cause the autopilot's automatic trim to run, resulting in an out-of-trim condition or cause the trim to hit the stop if the action is prolonged. In this case, larger than anticipated control forces may be required after the autopilot is disengaged

Recommended steps for the preflight check:

- 1) Autopilot - ENGAGE (using AP button, or AP button on mode controller)
- 2) AP DISC button - PRESS (verify autopilot disengages and audio alert is heard).
- 3) Verify yaw damper - OFF (if installed) (verify yaw damper disengages and audio alert is heard).
- 4) Flight director - SET FOR TAKEOFF (select TO or VS mode or push FD Button to turn off the Flight Director).
- 5) Flight controls - CHECK (verify autopilot servos are disengaged from pitch, roll, and yaw controls, and all controls move freely).
- 6) Elevator trim control - SET FOR TAKEOFF.

FLIGHT DIRECTOR OPERATION

The Flight Director function provides pitch and roll commands to the pilot and autopilot, which are displayed on the ADI Page. With the flight director active, the aircraft can be hand-flown to follow the path shown by the Command Bars. The flight director has the following maximum commands: pitch (-15°, +20°) and roll (30°) angles.

Activating The Flight Director

An initial press of a key listed in the table below (when the flight director is not active) activates the flight director in the listed modes. The flight director may be turned off and the Command Bars removed from the display by pressing the **FD** Key again. The **FD** Key is disabled when the autopilot is engaged.

| Control Pressed | Modes Selected | | | |
|------------------|---|---------------------|---|----------|
| | Lateral | | Vertical | |
| FD Key | Roll Hold (default) | ROL | Pitch Hold (default) | PIT |
| AP Key | Roll Hold (default) | ROL | Pitch Hold (default) | PIT |
| GA Button | Takeoff (on-ground) Go Around (in-air) | TO GA | Takeoff (on-ground) Go Around (in-air) | TO GA |
| ALT Key | Roll Hold (default) | ROL | Altitude Hold | ALT |
| VS Key | Roll Hold (default) | ROL | Vertical Speed | VS |
| VNAV Key | Roll Hold (default) | ROL | Vertical Navigation* | VNAV |
| IAS Key | Roll Hold (default) | ROL | Indicated Airspeed | IAS |
| APR Key | Approach** | GPS/VOR/ LOC/ILS | Pitch Hold (default) | PIT |
| NAV Key | Navigation** | GPS/VOR/ LOC | Pitch Hold (default) | PIT |
| HDG Key | Heading Select | HDG | Pitch Hold (default) | PIT |
| TRK Key | Track Select | TRK | Pitch Hold (default) | PIT |
| LVL Key | Level Hold | LVL | Level Hold | LVL |

*Must be receiving VNAV data from a GPS navigator.

**The selected navigation receiver must have an active GPS course before NAV or APR Key press activates flight director.

Flight Director Activation (GMC 507)

Flight Director Modes

Flight director modes are normally selected independently for the pitch and roll axes. Unless otherwise specified, all mode keys are alternate action (i.e., press on, press off). In the absence of specific mode selection, the flight director reverts to the default pitch and/or roll modes. Armed modes are annunciated in white and active in green in the AFCS Status Box. Under normal operation, when the control for the active flight director mode is pressed, the flight director reverts to the default mode(s) for the axis(es). Automatic transition from armed to active mode is indicated by the white armed mode annunciation moving to the green active mode field and flashing for 10 seconds.

If the information required to compute a flight director mode becomes invalid or unavailable, the flight director automatically reverts to the default mode for that axis. A flashing yellow mode annunciation and annunciator light indicate loss of sensor or navigation data required to compute commands.

When such a loss occurs, the system automatically begins to roll the wings level (enters Roll Hold Mode) or maintain the pitch angle (enters Pitch Hold Mode), depending on the affected axis. The flashing annunciation stops when the affected mode key is pressed or another mode for the axis is selected. If after 10 seconds no action is taken, the flashing annunciation stops. The flight director is automatically disabled if the attitude information required to compute the default flight director modes becomes invalid or unavailable.

Command Bars

Upon activation of the flight director, Command Bars are displayed in magenta on the ADI Page. For Single Cue Flight Director, if the aircraft is being flown by hand, the command bars are displayed hollow. The Single Cue Flight Director Command Bars do not override the Aircraft Symbol. The Command Bars move together vertically to indicate pitch commands and bank left or right to indicate roll commands. If the attitude information being sent to the flight director becomes invalid or unavailable, the Command Bars are removed from the display.

Hollow Command Bars (Pilot Hand Flying Aircraft, FD Only)

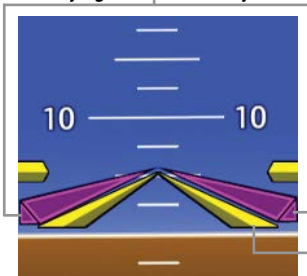

Solid Command Bars (Autopilot Engaged)

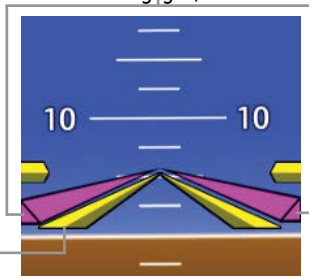

Aircraft Symbol

Command Bars - Single Cue Flight Director

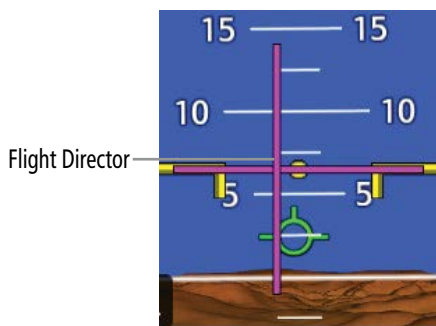

Flight Director - Dual Cue

VERTICAL MODES

The table lists the vertical modes with their corresponding controls and annunciations. The mode reference is displayed next to the active mode annunciation for Altitude Hold, Vertical Speed, and Indicated Airspeed modes.

The **NOSE UP/DN** Wheel can be used to change the vertical mode reference while operating under Pitch Hold, Vertical Speed, Indicated Airspeed, or Altitude Hold modes. Increments of change of values for each of these references using the **NOSE UP/DN** Wheel, are also listed in the table.

| Vertical Mode | Description | Control | Annunciation | Reference Change Increment |
|---------------|--|-----------|--------------|----------------------------|
| Pitch Hold | Holds the current aircraft pitch attitude; may be used to climb/descend to the Selected Altitude | (default) | PIT | 0.5° |

| Vertical Mode | Description | Control | Annunciation | Reference Change Increment |
|---------------------------|---|------------------|--------------|----------------------------|
| Selected Altitude Capture | Captures the Selected Altitude | * | ALTS | 10 ft |
| Altitude Hold | Holds the current Altitude | ALT Key | ALT | |
| Vertical Speed | Maintains the current aircraft vertical speed; may be used to climb/descend to the Selected Altitude | VS Key | VS | 100 fpm |
| Indicated Airspeed (IAS) | Maintains the current aircraft airspeed in IAS while the aircraft is climbing/descending to the Selected Altitude | IAS Key | IAS | 1 kt |
| Vertical Navigation | Captures and tracks descent legs of an active vertical profile | VNAV Key | VNAV | |
| Glidepath | Captures and tracks the GPS WAAS glidepath on approach | APR Key | GP | |
| Glideslope | Captures and tracks the ILS glideslope on approach | | GS | |
| Takeoff | Commands a constant pitch angle and wings level on-ground in preparation for takeoff | GA Button | TO | |
| Go Around | Commands a constant pitch angle and wings level in the air | | GA | |

*ALTS armed automatically when PIT, VS, IAS, TO, or GA active, and under VNAV when Selected Altitude is to be captured instead of VNAV Target Altitude

Vertical Modes

Pitch Hold Mode (PIT)

When the flight director is activated (**FD** Key pressed) or when the autopilot is activated, Pitch Hold Mode is selected by default. Pitch Hold Mode is indicated as the active vertical mode by the green 'PIT' annunciation. This mode may be used for climb or descent to the Selected Altitude (shown above the Altimeter), since Selected Altitude Capture Mode is automatically armed when Pitch Hold Mode is activated.

In Pitch Hold Mode, the flight director maintains a constant pitch attitude. The pitch reference is set to the aircraft pitch attitude at the moment of mode selection. If the aircraft pitch attitude exceeds the flight director pitch command limitations, the flight director commands a pitch angle equal to the nose-up/down limit.

Changing the pitch reference:

When operating in Pitch Hold Mode, the pitch reference can be adjusted by using the **Nose UP/DN** wheel.



Selected Altitude Capture Mode (ALTS)

Selected Altitude Capture Mode is automatically armed with activation of the following modes:

- Pitch Hold
- Vertical Speed
- Indicated Airspeed
- TO/GO Around
- Vertical Path Tracking

The white 'ALTS' annunciation indicates Selected Altitude Capture Mode is armed.



As the aircraft nears the Selected Altitude, the flight director automatically transitions to Selected Altitude Capture Mode with Altitude Hold Mode armed. This automatic transition is indicated by the green 'ALTS' annunciation flashing for up to 10 seconds and the appearance of the white 'ALTS' annunciation.

At 50 feet from the Selected Altitude, the flight director automatically transitions from Selected Altitude Capture to Altitude Hold Mode and holds the reference altitude. As Altitude Hold Mode becomes active, the white 'ALTS' annunciation moves to the active vertical mode field and flashes green for 10 seconds to indicate the automatic transition.

Setting the selected altitude:

Use the ALT SEL Knob on the GMC 507 to adjust the selected altitude.

Or:

- 1) Touch the Altitude Select field on the GI 275.
- 2) Change the value by rotating the Small Knob.



Syncing to the current altitude:

Press the ALT Sel Knob on the GMC 507.

Or:

- 1) Touch the Altitude Select field on the GI 275.
- 2) Sync current altitude by pushing the Small Knob.

Changing the Selected Altitude while Selected Altitude Capture Mode is active causes the autopilot to revert to Pitch Hold Mode with Selected Altitude Capture Mode armed for the new Selected Altitude.

Altitude Hold Mode (ALT)

Altitude Hold Mode can be activated by pressing the **ALT** Key; the AFCS maintains the current aircraft altitude (to the nearest 10 feet) as the Altitude Reference. Altitude Hold Mode active is indicated by a green 'ALT' annunciation in the GI 275 Autopilot Status Box.

Altitude Hold Mode is automatically armed when in Selected Altitude Capture Mode. Selected Altitude Capture Mode automatically transitions to Altitude Hold Mode when within 50 feet of the Selected Altitude. In this case, the Selected Altitude becomes the Altitude Reference.

Changing the Altitude Reference

When operating in Altitude Hold Mode, the Altitude Reference can be adjusted in the following ways:

- The Altitude Reference can be adjusted up or down in 10-foot increments by rolling the **NOSE UP/DN** Wheel. Using this method, up to 200 feet of altitude change can be commanded. To change the Altitude Reference by more than 200 feet, use another vertical mode (PIT, VS) to capture the desired Selected Altitude.

Vertical Speed Mode (VS)

In Vertical Speed Mode, the flight director acquires and maintains a Vertical Speed Reference. Current aircraft vertical speed (to the nearest 100 fpm) becomes the Vertical Speed Reference at the moment of Vertical Speed Mode activation. This mode may be used for climb or descent to the Selected Altitude (shown above the Altimeter) since Selected Altitude Capture Mode is automatically armed when Vertical Speed Mode is selected.

When Vertical Speed Mode is activated by pressing the **VS** Key, 'VS' is annunciated in green in the Autopilot Status Box. The Vertical Speed Reference is also displayed next to the Vertical Speed mode annunciation.

Changing the Vertical Speed Reference



NOTE: VS Mode is limited to 2000' FPM

Use the **NOSE UP/DN** Wheel to adjust the Vertical Speed Reference in increments of 100 fpm.

HDG | VS↑1.4 | ALTS

Indicated Airspeed Mode (IAS)

Indicated Airspeed Mode is selected by pressing the IAS Key on the GMC 507. This mode acquires and maintains the Airspeed Reference (IAS) while climbing or descending. When Indicated Airspeed Mode is active, the flight director continuously monitors Selected Altitude, airspeed and altitude.

The Airspeed Reference is set to the current airspeed upon mode activation. Indicated Airspeed Mode is indicated by a green 'IAS' annunciation in the Autopilot Status Box. The Airspeed Reference is also displayed as a cyan bug corresponding to the Airspeed Reference along the airspeed tape.

Engine power must be adjusted to allow the autopilot to fly the aircraft at a pitch attitude corresponding to the desired flight profile (climb or descent) while maintaining the Airspeed Reference.

Changing the Airspeed Reference

The Airspeed Reference (shown in both the Autopilot Status Box and above the Airspeed Indicator) may be adjusted by using the **NOSE UP/DN** Wheel.

ROL | AP YD | IAS151

Vertical Navigation Mode (VNAV)



NOTE: If another vertical mode is touched while VNAV Mode is selected, VNAV Mode reverts to armed.



NOTE: VNAV mode will not capture a descending profile unless the selected altitude is valid and at least 75 feet below the current aircraft altitude.

Vertical Navigation (VNAV) Mode is available for enroute/terminal cruise and descent operations any time that VNAV input data is being received.

Activating vertical navigation mode:

- 1) When a flight plan is active, VNAV data is valid, and the **VNAV** Key is selected, VNAV mode is armed in preparation for descent path capture. 'VNAV' is annunciated in white in the GI 275 Autopilot Status Box.
- 2) When a descent leg is captured (i.e., vertical deviation becomes valid), VNAV Mode is activated and tracks the descent profile.
- 3) Level off when approaching the Selected Altitude.

If the altimeter's barometric setting is adjusted while VNAV mode is active, the autopilot increases/decreases the descent rate by up to 500 fpm to re-establish the aircraft on the descent path (without commanding a climb). For large changes, it may take several minutes for the aircraft to reestablish on the descent path.

Automatic Reversion to Pitch Hold Mode

Several situations can occur while VNAV Mode is active which cause the AFCS to revert to Pitch Hold Mode:

- The aircraft does not level off at the selected altitude.
- Vertical deviation exceeds 200 feet during an overspeed condition.
- Vertical deviation becomes invalid (the Deviation Indicator is removed from the ADI Page).

Following a reversion to Pitch Hold Mode, VNAV Mode becomes armed to allow for possible profile recapture.

Glidepath Mode (GP) (with external WAAS enabled IFR navigator ONLY)

Glidepath Mode is used to track a WAAS or other satellite-based augmentation system WAAS generated glidepath. When Glidepath Mode is armed, 'GP' is annunciated in white in the Autopilot Status Box.

Selecting glidepath mode:

- 1) **EXTERNAL NAVIGATOR:** Ensure a GPS approach with vertical guidance (LPV, LNAV/VNAV, LNAV +V) is loaded into the active flight plan. The active waypoint must be part of the flight plan (cannot be a direct-to a waypoint not in the flight plan).
- 2) Ensure that GPS is the selected navigation source.
- 3) Press the **APR** Key on the GMC 507.



NOTE: Some RNAV (GPS) approaches provide a vertical descent angle as an aid in flying a stabilized approach. These approaches are **NOT** considered Approaches with Vertical Guidance (APV). Approaches that are annunciated on the HSI as LNAV or LNAV+V are considered Non-precision Approaches (NPA) and are flown to an MDA even though vertical glidepath (GP) information may be provided.



WARNING: When flying an LNAV approach (with vertical descent angle) with the autopilot coupled, the aircraft will not level off at the MDA even if the MDA is set in the altitude preselect.

Upon reaching the glidepath, the flight director transitions to Glidepath Mode and begins to capture and track the glidepath.

Once the following conditions have been met, the glidepath can be captured:

- The active waypoint is at or after the final approach fix (FAF).
- Vertical deviation is valid.
- The CDI is at less than full-scale deviation.
- Automatic sequencing of waypoints has not been suspended.

Glideslope Mode (GS)

Glideslope Mode is available for LOC/ILS approaches to capture and track the glideslope. When Glideslope Mode is armed (annunciated as 'GS' in white), LOC Approach Mode is armed as the lateral flight director mode.



NOTE: Glideslope Mode requires a valid GPS position.

Selecting Glideslope Mode:

- 1) EXTERNAL NAVIGATOR: Tune and activate the desired localizer frequency.
- 2) EXTERNAL NAVIGATOR: Ensure that LOC is the selected navigation source.
- 3) Press the **APR** Key on the GMC 507.

Or:

- 1) EXTERNAL NAVIGATOR: Tune and activate the desired localizer frequency.
- 2) EXTERNAL NAVIGATOR: Load the approach (LOC, ILS, LDA, SDF, etc) into the flight plan.
- 3) Press the **APR** Key on the GMC 507.

Once LOC is the navigation source, the localizer and glideslope can be captured. Upon reaching the glideslope, the flight director transitions to Glideslope Mode and begins to capture and track the glideslope.

Go Around (GA) and Takeoff (TO) Modes:

Go Around and Takeoff modes are coupled pitch and roll modes and are annunciated as both the vertical and lateral modes when active. In these modes, the flight director commands a constant set pitch attitude and keeps the wings level. The GA Switch is used to activate both modes. The mode entered by the flight director depends on whether the aircraft is on the ground or in the air.

Takeoff Mode provides an attitude reference during rotation and takeoff. This mode can be selected only while on the ground by pushing the Go Around Button. The flight director Command Bars assume a wings-level, pitch-up attitude.

Pressing the Go Around Button while in the air activates the flight director in a wings-level, pitch-up attitude, allowing the execution of a missed approach or a go around. Go Around Mode arms Selected Altitude Capture Mode automatically when the altitude preselect bug is set at least 100 ft above the current altitude, and attempts to modify the aircraft attitude (i.e., with the **NOSE UP/DN** Wheel) will result in reversion to Pitch and Roll Hold modes.

LATERAL MODES

The following table lists the lateral modes and respective control(s) and annunciation. Refer to the vertical modes section for information regarding Takeoff and Go Around Modes.

| Lateral Mode | Description | Control | Annunciation |
|--|--|----------------|--------------|
| Roll Hold | Holds the current aircraft roll attitude or rolls the wings level, depending on the commanded bank angle | (default) | ROL |
| Heading | Captures and tracks the Selected Heading | HDG Key | HDG |
| Track | Captures and tracks the Selected Ground Track | TRK Key | TRK |
| Navigation, GPS | Captures and tracks the selected navigation source (GPS, VOR, LOC) | NAV Key | GPS |
| Navigation, VOR Enroute Capture/Track | | | VOR |
| Navigation, LOC Capture/Track (No Glideslope) | | | LOC |
| Approach, GPS | Captures and tracks the selected navigation source (GPS, VOR, LOC, BC) | NAV Key | GPS |
| Approach, VOR Capture/Track | | | |
| Approach, LOC Capture/Track (Glideslope Mode automatically armed) | | | LOC |
| Approach, BC Capture/ Track | | | BC |

| Lateral Mode | Description | Control | Annunciation |
|--------------|--|----------------------------|--------------|
| Takeoff | Commands a constant pitch angle and wings level on-ground in preparation for takeoff | Go Around Button | TO |
| Go Around | Commands a constant pitch angle and wings level in the air | | GA |

Flight Director Lateral Modes

Roll Hold Mode (ROL)



NOTE: If Roll Hold Mode is activated as a result of a mode reversion, the flight director rolls the wings level.

When the flight director is activated or switched, Roll Hold Mode is selected by default. This mode is annunciated as 'ROL' in the Autopilot Status Box. The current aircraft bank angle is held, subject to the bank angle condition.

ROL | AP YD | ALT 2³⁰⁰

| Bank Angle | Flight Director Response |
|------------|--|
| < 6° | Rolls wings level |
| 6 to 20° | Maintains current aircraft roll attitude |
| > 20° | Limits bank to 20° |

Roll Hold Mode Responses

Heading Select Mode (HDG)



NOTE: A magnetometer is required for Heading Select Mode (HDG).

Heading Select Mode is activated by pressing the **HDG** Key. Heading Select Mode acquires and maintains the Selected Heading. On the ADI, the Selected Heading is shown by a cyan bug on the Heading tape and in the box on the bottom left of the display, and on the HSI, the selected heading is shown by a cyan bug on the perimeter of the compass card, in a box on the bottom left of the display.

Changing the selected heading:

- 1) Touch the Heading Selection field.
- 2) Rotate the Small Knob to change selected Heading.

Or:

Rotate the **HDG/TRK** Knob.

Activating heading mode:



Press the **HDG** Key on the GMC 507.

Turns are commanded in the same direction as Selected Heading Bug movement, even if the bug is turned more than 180° from the present heading (e.g., a 270° turn to the right). However, Selected Heading changes of more than 330° at a time result in turn reversals.

Track Mode (TRK)

Track Mode is activated by pressing the **TRK** Key on the GMC 507. Track Mode acquires and maintains the Selected Ground Track. On the ADI, the Selected Ground Track is displayed as a cyan bowtie bug on the Heading tape and in the box on the bottom left of the display. On the HSI, the Selected Ground Track is displayed as a cyan bowtie bug on the perimeter of the compass card, and in the box on the bottom left of the display.

Changing the selected ground track:

- 1) Touch the Track Selection field.
- 2) Rotate the Small Knob to change selected Track.

Or:

Rotate the **HDG/TRK** Knob.

Activating track mode:



Press the **TRK** Key on the GMC 507.

Turns are commanded in the same direction as Selected Heading Bug movement, even if the bug is turned more than 180° from the present heading (e.g., a 270° turn to the right). However, Selected Heading changes of more than 330° at a time result in turn reversals.

Navigation Mode (GPS, VOR, LOC)



NOTE: The GI 275 must have a valid GPS position for VOR and LOC Modes.



NOTE: Dual navigators are supported for the GFC 500.



NOTE: When intercepting a flight plan leg, the flight director gives commands to capture the active leg at approximately a 45° angle to the track between the waypoints defining the active leg. The flight director does not give commands fly to the starting waypoint of the active leg.

Pressing the **NAV** Key selects Navigation Mode. Navigation Mode acquires and tracks the navigation source. The flight director follows GPS roll steering commands when GPS is the navigation source. Navigation Mode can also be used to fly non-precision GPS, VOR, and LOC approaches where vertical guidance is not required.

If the Course Deviation Indicator (CDI) shows greater than one dot when the **NAV** Key is pressed, the selected mode is armed. If the CDI is less than one dot, Navigation Mode is automatically captured when the **NAV** Key is pressed. The armed annunciation appears in white to the left of the active roll mode.

If Navigation Mode is active and any of the following occur, the AFCS reverts to Roll Hold Mode (wings rolled level):

- Active navigation source manually switched
- Navigation input is lost
- GPS reception is lost

Approaches Without Vertical Guidance



NOTE: The selected navigation receiver must have an active GPS course for the flight director to enter Approach Mode.

Press the **NAV** Key to arm/activate GPS (LNAV only) lateral mode. The lateral mode acquires and tracks the selected navigation source, depending on the loaded approach. Press **NAV** when the CDI is greater than one dot to arm the selected mode (annunciated in white). Press **NAV** when the CDI deviation is less than one dot to activate, capture and track the selected navigation source.

| Example | Control | Lateral Mode | Annunciation | Description |
|---------|---------|----------------------------|--------------|--|
| LNAV | NAV Key | Approach, GPS | GPS | Captures and tracks the selected navigation source (GPS, VOR, LOC, BC) |
| VOR | | VOR Approach Capture/Track | VOR | |
| LOC | | LOC Approach Capture/Track | LOC | |
| BC | | BC Approach Capture/Track | BC | |

Approach Without Vertical Guidance

GPS Approach Without Vertical Guidance

A GPS approach without vertical guidance (LNAV) is flown using GPS NAV Mode.

GPS | AP YD | ALT 2150 GP

Selecting a GPS Approach without vertical guidance:

- 1) EXTERNAL NAVIGATOR: Ensure a GPS approach without vertical guidance (LNAV) is loaded into the active flight plan.
- 2) EXTERNAL NAVIGATOR: Ensure the 'GPS' indication is showing in the lower-left corner. If not, press the **CDI** Key on the navigator.
- 3) EXTERNAL NAVIGATOR: Select and activate the GPS approach using the PROC Key.
- 4) Press the **NAV** Key.
- 5) Adjust the aircraft's pitch as required.

VOR Approach

A VOR approach is flown using VOR Mode.

Selecting a VOR Approach:

- 1) EXTERNAL NAVIGATOR: Tune and activate the desired VOR frequency.
- 2) EXTERNAL NAVIGATOR: Ensure the 'VLOC' indication is showing in the lower-left corner. If not, press the **CDI** Key on the navigator.
- 3) Ensure that VOR1 or VOR2 is the selected navigation source on the HSI Page. It should say 'VOR1' or 'VOR2' on the HSI and the pointer should be green.
- 4) From the HSI Page, press the Selection Knob to display the Menu.
- 5) Set the inbound approach course. Select **Course** and use the Selection Knob to adjust the course.
- 6) Press the **NAV** Key on the GMC 507.
If there is less than half-scale deviation when the **NAV** Key is pressed, VOR Mode will activate (green text), intercept, and track the selected radial. If there is more than half-scale deviation when the **NAV** Key is pressed, VOR Mode will arm (white text) first, then activate when closer to the radial.
- 7) Adjust the aircraft's pitch axis as required.

Localizer Approach (No GS)

LOC Mode is used to fly a localizer only approach (no glideslope).

Selecting LOC Mode for a localizer only approach:

- 1) EXTERNAL NAVIGATOR: Tune and activate the desired LOC frequency.
- 2) Ensure the 'LOC1' indication is showing in the lower-left corner. If not, press the **CDI** Key on the navigator. The HSI should automatically slew the pointer to the correct course.
- 3) Press or the **NAV** Key on the GMC 507.

If the localizer deviation is less than half-scale when the **NAV** Key is pressed, the autopilot will activate LOC Mode and track the localizer, otherwise LOC Mode is armed and the pilot is responsible for intercepting the localizer. In some cases it may be necessary to use HDG Mode with LOC Mode armed to follow a vector to the localizer.

GPS Approaches With Lateral + Vertical Guidance

Press the **APR** Key to arm/activate both lateral and vertical modes for approach. When Glidepath (GP) Mode is armed for a GPS approach with vertical guidance, GPS Mode is automatically armed. Press the **APR** Key when the CDI is greater than one dot to arm the selected modes (annunciated in white). Press the **APR** Key when the CDI deviation is less than one dot to activate, capture and track the selected navigation source.

| Example | Control | Modes | Annunciation | Description |
|-------------------------------|----------------|----------------------|--------------|---|
| LPV, LNAV/ VNAV, LNAV+V | APR Key | Lateral: GPS | GPS | Captures and tracks the lateral portion of a GPS approach |
| | | Vertical: Glidepath | GP | Captures and tracks a WAAS approach glidepath |
| LOC, ILS | APR Key | Lateral: Localizer | LOC | Captures and track the localizer |
| | | Vertical: Glideslope | GS | Captures and tracks the glideslope |

Lateral + Vertical Approaches

GPS Approach with Vertical Guidance



NOTE: To cancel Glidepath (GP) Mode without cancelling GPS Mode, press NAV once. Pressing it a second time cancels GPS Mode.

When Glidepath (GP) Mode is armed for a GPS approach with vertical guidance, GPS Mode is automatically armed.

Selecting a GPS approach with vertical guidance:

- 1) EXTERNAL NAVIGATOR: Ensure a GPS approach with vertical guidance (LPV, LNAV/VNAV, LNAV+V) is loaded into the active flight plan.
- 2) EXTERNAL NAVIGATOR: Ensure the 'GPS' indication is showing in the lower-left corner. If not, press the **CDI** Key.
- 3) EXTERNAL NAVIGATOR: Select and activate the GPS approach using the **PROC** Key.
- 4) Press the **APR** Key.

Localizer with Glideslope

LOC Mode (lateral) and GS Mode (vertical) are both armed by pressing the **APR** Key on the GMC 507. LOC/ILS approach captures are inhibited if the difference between aircraft heading and localizer course exceeds 105°.



NOTE: To cancel Glideslope (GS) Mode without cancelling LOC Mode, press NAV once. Pressing it a second time cancels LOC Mode.

Selecting LOC Mode with GS Mode:

- 1) EXTERNAL NAVIGATOR: Tune and activate the desired LOC frequency.
- 2) EXTERNAL NAVIGATOR: Ensure the 'LOC1' indication is showing in the lower-left corner. If not, press the **CDI** Key. The HSI should automatically slew the pointer to the correct course.
- 3) Press the **APR** Key on the GMC 507.

This simultaneously selects LOC Mode and GS (Glideslope) Mode. If the localizer deviation is less than half-scale when the APR Key is pressed, the autopilot will activate LOC Mode and track the localizer, otherwise LOC Mode is armed and the pilot is responsible for intercepting the localizer.

If the following occurs, the autopilot reverts to Roll Hold Mode (wings rolled level):

- Approach Mode is active and the Navigation source is manually switched
- The localizer signal is lost

If the Glideslope signal is lost, GS Mode will revert to Pitch Hold Mode and hold the last pitch attitude.

Backcourse Approach

NOTE: When making a backcourse approach, set the Selected Course to the localizer front course.

Backcourse Mode captures and tracks a localizer signal in the backcourse direction. Backcourse is indicated by 'BC' in the autopilot status box.

If GS and LOC Mode are armed, the autopilot can only capture the localizer front course, indicated by 'LOC' in the autopilot status box. If only LOC Mode is armed (not GS Mode), the autopilot will capture either the front course or the backcourse based on the angle at which the aircraft intercepts the localizer.

Selecting BC Mode:

- 1) EXTERNAL NAVIGATOR: Tune and activate the desired LOC frequency.
- 2) EXTERNAL NAVIGATOR: Ensure the 'LOC1' indication is showing in the lower-left corner. If not, press the **CDI** Key.
- 3) EXTERNAL NAVIGATOR: Select the front course on the CDI.
- 4) Press the **NAV** Key on the GMC 507.



NOTE: If the aircraft heading is within 75° of the localizer backcourse then BC Mode will be armed. If the aircraft heading is within 105° of the localizer front course, LOC Mode will be armed.

Level Mode

Level Mode is coupled in pitch and roll modes and is annunciated as both the vertical and lateral modes when active. Pressing the **LVL** Key engages the autopilot in Level vertical and lateral modes. Level Mode does not track altitude or heading. When the **LVL** Key is pressed all armed and active modes are cancelled and the autopilot and flight director revert to LVL mode for pitch and roll. While in level mode, all other modes are available by pressing the corresponding key.

6.6 GFC 500 AFCS ALERTS

TRIM ALERTS

If the commanded operation cannot be achieved due to the limitations configured, the following messages can be displayed over the pitch scale. The annunciation is removed once the condition is resolved.

| Alert Condition | Annunciation | Description |
|-----------------------------|------------------|--|
| Up-elevator Trim Required | TRIM UP | The autopilot does not have the required elevator authority to reach the desired flight condition. |
| Down-elevator Trim Required | TRIM DOWN | |

Status Alerts







SPEED ALERTS

If the remote autopilot unit supports speed alerts and the airspeed limitations configured have been reached, the following messages can be displayed the airspeed tape. The annunciation is removed once the condition is resolved.

| Alert Condition | Annunciation | Description |
|-----------------------|---------------|---|
| High speed Protection | MAXSPD | Autopilot unit will raise the nose to limit the aircraft's speed. |
| Low speed Protection | MINSPD | Autopilot unit will lower the nose to prevent the aircraft's speed from decreasing. |

Speed Alerts

GFC 500 MESSAGES AND ANNUNCIATIONS

| Autopilot Messages | |
|---|--|
| AFCS Controller Key Stuck | The system has sensed a key input on the GMC 507 for 30 seconds or longer. |
| AFCS Controller Audio Database Missing | The audio database is missing from the GMC 507. The aural voice alerts will not be heard. |
| Servo Clutch Fault | One or more autopilot servos has a stuck clutch. The servo needs service. |
| Servo Trim Input Fault | The inputs to the trim system are invalid. The trim system needs service. |
| Autopilot Annunciations | |
|  | Autopilot has failed. Autopilot and trim are inoperative and flight director is not available. |
|  | Autopilot normal disconnect. |
|  | Autopilot abnormal disconnect. |
|  | Autopilot has failed. The autopilot is inoperative. FD modes may still be available. |
|  | Electronic Stability and Protection is Off. |
|  | Autopilot preflight test is in progress. |
|  | Pitch Trim Fail – Manual Electric Pitch Trim is inoperative. |

GFC 500 Messages and Annunciations

6.7 ELECTRONIC STABILITY & PROTECTION (ESP) (GFC 500)



WARNING: Do not assume ESP will provide stability protection in all circumstances. There are in-flight situations that can exceed the capabilities of ESP technology.



WARNING: A GPS navigator that can provide AGL height data is required for low-air speed protection.



WARNING: The autopilot (or ESP) will disengage if the roll attitude exceeds 75° or the pitch attitude exceeds 50°.



NOTE: *GI 275 Software 3.0 and newer allows the pilot to disable ESP when the AP Disconnect input has been held for more than 5 (five) seconds.*

Electronic Stability and Protection (ESP) is a feature that is intended to monitor the aircraft and provide control input feedback when necessary to discourage operating the aircraft at potentially unsafe attitudes and/or airspeeds. If enabled, this feature will automatically arm when the aircraft is above 500 feet AGL and the autopilot is not engaged, and disarm when below 200 feet AGL (if AGL height data is unavailable, ESP can be armed on the ground, but low-air-speed protection will not be available).

When selected, ESP engages automatically when the aircraft approaches or exceeds one or more predetermined airspeed or attitude limitations. Stability protection for each flight axis is provided by the autopilot servos, which apply force to the appropriate control surface(s) to discourage pilot control inputs that would cause the aircraft to exceed the normal or "protected" flight envelope. This is perceived by the pilot as resistance to control movement in the undesired direction when the aircraft approaches a steep attitude, and/or the airspeed is below the minimum or above the maximum configured airspeed.

As the aircraft deviates further from the normal attitude and/or airspeed, the force increases proportionally (up to an established maximum) to encourage control movement in the direction necessary to return to the normal attitude and/or airspeed range. When ESP has been engaged for more than 10 seconds (cumulative; not necessarily consecutive seconds) of a 20-second interval, the autopilot can be configured to engage with the flight director in Level Mode, bringing the aircraft into level flight. An aural "Engaging Autopilot" alert is played and the flight director mode annunciation will indicate 'LVL' for vertical and lateral modes.

Level mode as activated by ESP is limited by altitude. ESP will not be able to activate Level mode until the aircraft climbs above 2000 feet AGL. ESP will be locked out of automatically activating Level mode after the aircraft descends below 1500 feet AGL as well. Also note that Level mode as activated by ESP is different than manually selected Level mode. Manually selected Level mode is not limited by altitude at all.



NOTE: *If AGL height data is unavailable automatic engagement of Level mode is not supported.*

ESP is enabled or disabled from the ADI Page Menu.

Enabling/Disabling ESP:

- 1) From the ADI Page, press and hold the Selection Knob, or swipe up on the screen, to display the Menu.
- 2) Rotate the knob or swipe across the menu items to select ESP
- 3) Press the knob or touch the ESP menu button to enable or disable ESP.

Or:

Hold the AP Disconnect button for at least 5 seconds.

ROLL ENGAGEMENT

Roll Limit Indicators displayed on the roll scale are configurable between 45° and 60° right and left, indicating where ESP will engage. As roll attitude exceeds the configured limit, ESP will engage and the Roll Limit Indicators will move to 15° less than the configured ESP bank limit. The Roll Limit Indicator now indicates where ESP will disengage as roll attitude decreases.

Once engaged, the torque applied by ESP is at its maximum when bank angle is 15° more than the configured bank limit, and tapers to the minimum applied torque when the bank angle is 15° less than the configured bank limit. The force increases as roll attitude increases and decreases as roll attitude decreases. The applied force is intended to encourage pilot input to return the airplane to a more normal roll attitude. When beyond 15° of the configured bank limit, the maximum torque is held until the aircraft returns inside the protected envelope.

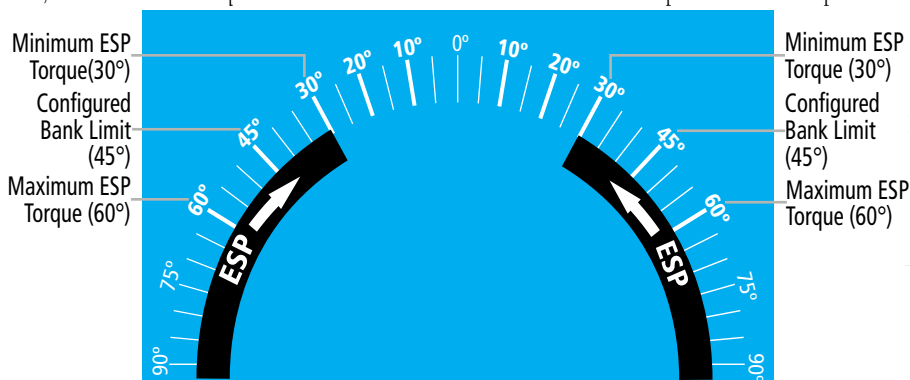

ESP Roll Operating Range When Engaged
(Force Increases as Roll Increases & Decreases as Roll Decreases)

PITCH ENGAGEMENT

ESP pitch engagement is configurable between 10° and 25° nose-up and between 5° and 25° nose-down. Once engaged, the torque applied by ESP is at its maximum when pitch is 5° more than the configured nose-up and nose-down pitch limits, and tapers to the minimum applied torque when pitch is 5° less than the configured nose-up and nose-down pitch limits. When beyond 5° of the configured pitch limit, the maximum torque is held until the aircraft returns inside the protected envelope.

The opposing force increases or decreases depending on the pitch angle and the direction of pitch travel. This force is intended to encourage movement in the pitch axis in the direction of the normal pitch attitude range for the aircraft.

- System Overview
- Flight Instruments
- EIS
- Navigation
- Hazard Avoidance
- Autopilot**
- WSI
- Additional Features
- Appendices
- Index

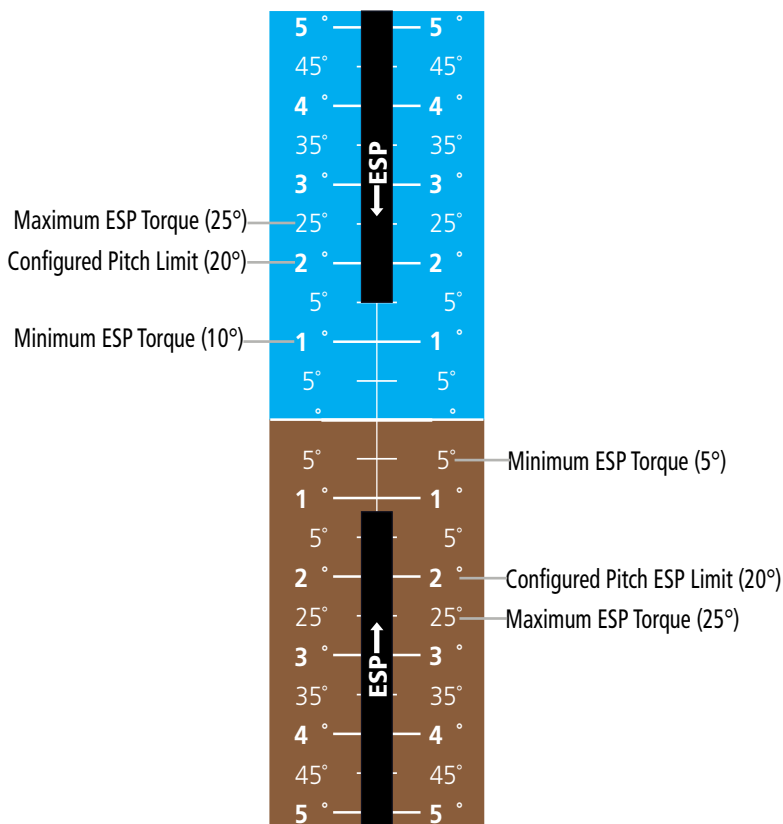

ESP Pitch Operating Range When Engaged
 (Force Increases as Pitch Increases & Decreases as Pitch Decreases)

AIRSPEED PROTECTION (GFC 500 ONLY)



NOTE: *If AGL height data is unavailable low-airspeed protection is not supported.*

An airspeed below the minimum configured airspeed or above maximum configured airspeed will result in ESP applying force to raise or lower the nose of the aircraft. When the high or low airspeed condition is remedied, ESP force is no longer applied.

SECTION 7 INSTANTANEOUS VERTICAL SPEED INDICATOR

7.1 OVERVIEW

The GI 275 TA/RA vertical speed indicator combines the plan position of intruding aircraft and TCAS II traffic alerts and resolution advisories on the vertical speed instrument.

The VSI display shows climb and descent rates on a white vertical speed scale. Climb and descend resolution advisories are shown as red and green bands outside of the scale, while the center of the display presents nearby traffic.



Instantaneous Vertical Speed Indicator

7.2 VERTICAL SPEED / RA DISPLAY

The vertical speed display shows climb and descent rates using a white pointer on a white vertical speed scale. The non-linear scale is marked at 500 (.5), 1000 (1), 2000 (2) 4000 (4) and 6000 (6) ft/min (fpm), with greater resolution at lower vertical speeds.

7.3 RESOLUTION ADVISORIES

TCAS resolution advisories (RAs) are depicted as red and green bands around the vertical speed scale. To follow an RA, avoid flying vertical speeds in the red banded areas, and do fly vertical speeds in the green banded areas when displayed.

7.4 TRAFFIC DISPLAY





The traffic display in the center of the indicator shows nearby traffic relative to a white airplane (own aircraft) symbol. The traffic display should be used as an aid to visual acquisition of nearby traffic only. A fixed 2 nm range ring is displayed as white dots around the own aircraft symbol, with the dots placed at the 12 clock positions. The distance from the own aircraft symbol to the top of the vertical speed scale corresponds to the selected display range.

The range of the traffic display is selected using the inner concentric knob. Rotating the knob counterclockwise increases the range, while rotating the knob clockwise decreases the range. Ranges of 4, 6, 12, 24 and 40 nm may be selected using the knob. The 2 nm range ring is removed from the display for ranges greater than 12 nm.



NOTE: If the system is configured to use an external ATC/TCAS control panel that allows range selection, rotating the Small Knob on the GI 275 will not change the range. Instead, the ATC/TCAS control panel will control the range and range increments.

The symbols used to display TCAS II traffic are as shown in the following table:

| Traffic Symbol | Description |
|---|---|
|  | Other Traffic - Traffic is beyond 6 nm and is neither a Traffic Advisory or Proximate Traffic. |
|  | Proximate Traffic - Indicates the intruding aircraft is within +/- 1200 feet and is within 6 nm range. |
|  | Traffic Advisory (TA) - Potentially hazardous intruding aircraft meets the closing rate, distance, and vertical separation parameters for TA criteria. |
|  | Resolution Advisory (RA) - Potentially hazardous intruding aircraft meets closing rate, distance, and vertical separation parameters for RA criteria. |

Traffic Symbol Description

Relative altitude, when available, is displayed above or below the corresponding traffic symbol in hundreds of feet. When this altitude is above own aircraft, it is displayed above the traffic symbol and it is preceded by a '+' symbol; a minus sign '-' indicates traffic is below own aircraft and is displayed below the traffic symbol. The system displays the traffic altitude vertical trend as an up/down arrow to the right of the traffic symbol (for traffic climbing or descending at vertical speeds greater than 500 fpm). No arrow is displayed for traffic climbing or descending at vertical speeds less than 500 fpm.



Intruder Altitude and Vertical Trend Arrow

TA and RA intruders are displayed as partial symbols for traffic beyond the selected traffic display range. The partial symbols are displayed at the appropriate bearing along the vertical speed scale. Other traffic and proximate traffic do not show partial symbols.

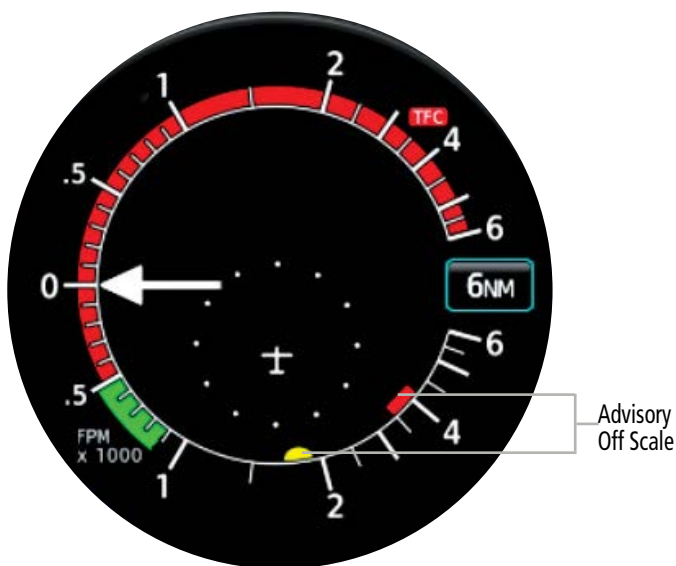

Resolution Advisory - Off Scale

If a TA or an RA intruder does not have a bearing, it will be displayed at a textual alert across the top portion of the traffic display. All textual TA's or RA's are in the format (alert type) (distance in nm) (relative altitude in hundreds of feet) (climbing or descending arrow, if applicable). The text is colored red (RA) or yellow (TA) based upon the alert type.



Textural Alerts

The traffic system automatically suppresses the display of altitude-reporting aircraft on the ground under either of the following conditions:

- On-ground aircraft is equipped with a Mode S transponder
- On-ground aircraft is equipped with a Mode C transponder

7.5 CONTROLS AND ANNUNCIATIONS

The GI 275 displays annunciations for the various TCAS II operating modes and system failures.

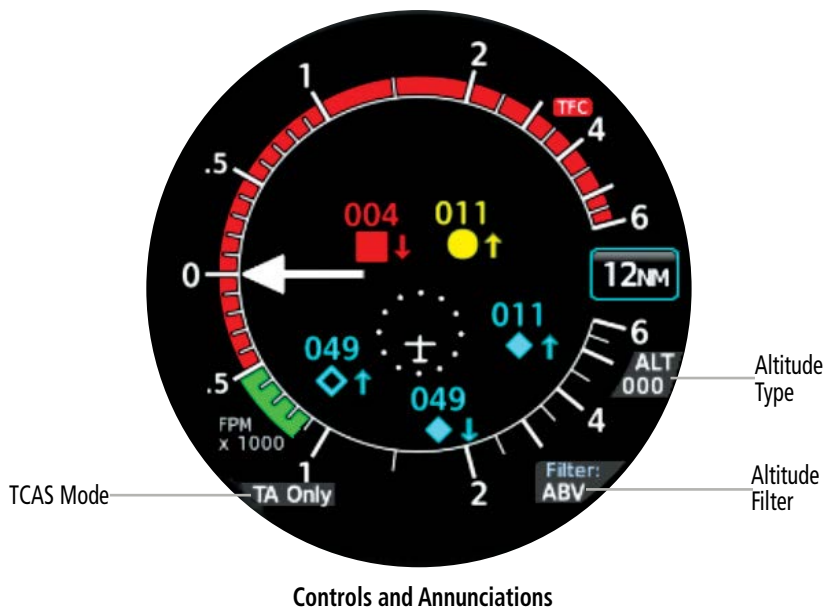

7.6 ALTITUDE FILTERING

The pilot can select the volume of airspace in which non-threat and proximity traffic is displayed. TA and RA traffic is always displayed regardless of the altitude filter settings. Below is a list of the different altitude settings available for filtering. For Normal filtering, the filter setting annunciation is not displayed; for all other settings, the filter setting is displayed.

- Normal (none): Displays non-threat and proximity traffic from 2700 feet above the aircraft to 2700 feet below the aircraft; typically used during enroute phase of flight
- Above (ABV): Displays non-threat and proximity traffic from 9000 feet above the aircraft to 2700 feet below the aircraft; typically used during climb phase of flight
- Below (BLW): Displays non-threat and proximity traffic from 2700 feet above the aircraft to 9000 feet below the aircraft; typically used during descent phase of flight
- Unrestricted (UNR): All traffic is displayed 9900 feet above to 9900 feet below the aircraft

Changing The Altitude Filtering Range:

- 1) Open the menu and select **Options > Altitude Filter**.
- 2) Select the desired Altitude Filter Button.

7.7 ALTITUDE TYPE

The pilot can select whether relative or absolute altitude is displayed for traffic. Below is a list of the different altitude settings (ALT) available for filtering. For a setting of Relative, the altitude type annunciation is not displayed; for all other settings, the filter setting is displayed.

- Relative (none): Displays all traffic with an altitude tag in hundreds of feet; the altitude displayed is relative to own aircraft altitude
- Absolute (000): Displays all traffic with an altitude tag in thousands of feet; altitude displayed is pressure altitude being reported by the traffic

Changing the Altitude Type:

- 1) Open the menu and select **Options > Altitude Type**.
- 2) Select the desired Altitude Type Button.

7.8 TRAFFIC COLLISION AVOIDANCE SYSTEM (TCAS) MODE

The mode of the TCAS is controlled using an external control panel and displayed on the GI 275. Below is a list of the different mode annunciations available for filtering. For a mode of TA/RA, the altitude type annunciation is not displayed; for all other modes, the TCAS mode is displayed.

- TA/RA (none): The TCAS will display traffic and issue Traffic Advisories (RA's) and Resolution Advisories (RA's)
- TA Only (TA Only): The TCAS will display traffic and issue RA's and but not RA's
- Standby (STBY): The TCAS is not operating and will not display traffic nor issue RA's or RA's
- TCAS Test (TEST): The TCAS is running a pilot-initiated self-test. A test pattern with the four different intruder types will be displayed on the GI 275.

7.9 FAILURE ANNUNCIATIONS

Vertical Speed Fail (X)

If the vertical speed fails, the vertical speed markings and pointer will be removed and the speed markings will be replaced with a yellow X. Traffic will continue to be displayed.

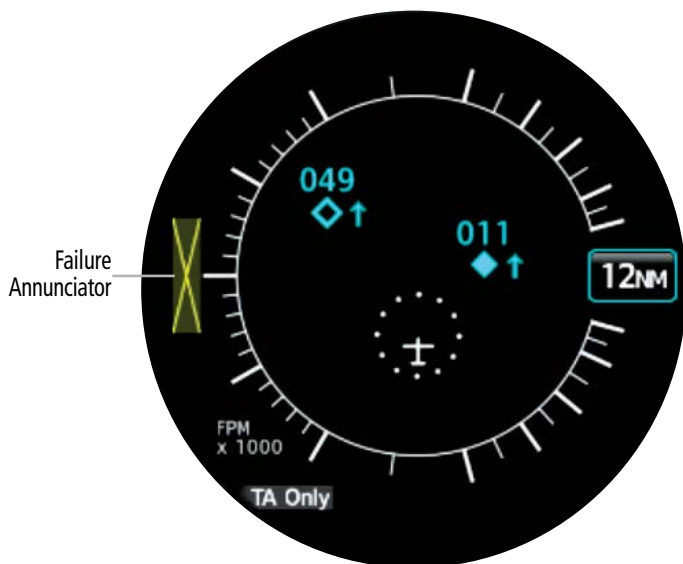

Vertical Speed Failure Annunciations

RA Fail

If the GI 275 or TCAS is in TA/RA mode and not able to deliver RAs, RA FAIL will be annunciated in yellow text across the top of the display. Traffic will continue to be displayed. If the failure is due to loss of vertical speed, the vertical speed markings and pointer will be removed and the speed markings will be replaced with a yellow X.

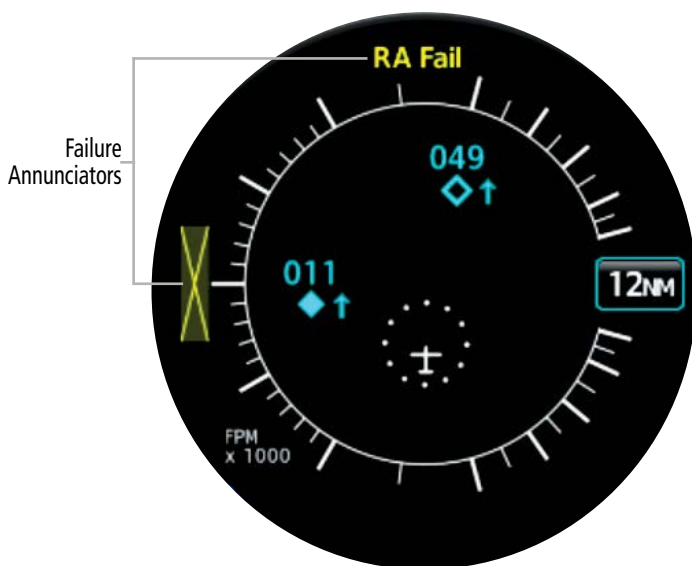

RA Failure Annunciations

TCAS Fail

If the TCAS has failed, TCAS FAIL will be annunciated in yellow text across the top of the display, indicating that TA's, RA's or traffic cannot be displayed. Vertical speed will continue to be displayed in this case.

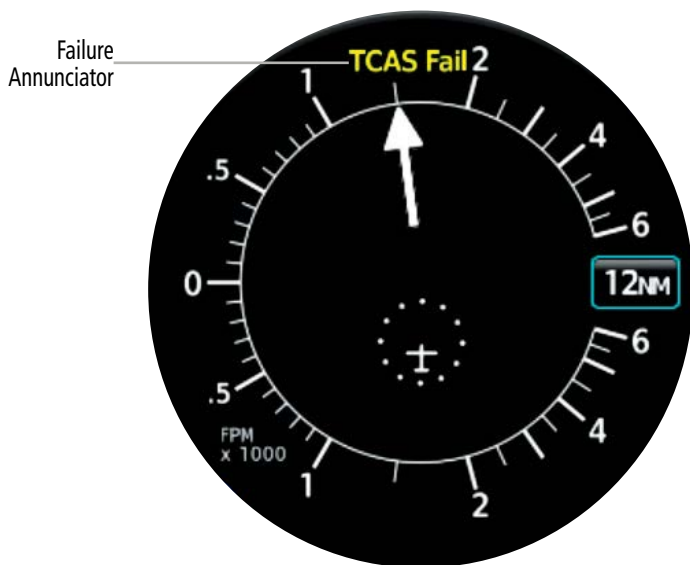

TCAS Failure Annunciations

TD Fail

If the TCAS is operational but the GI 275 cannot display traffic, TD Fail will be annunciated in yellow text across the center of the display, indicating that traffic cannot be displayed. RAs and vertical speed will continue to be displayed in this case.

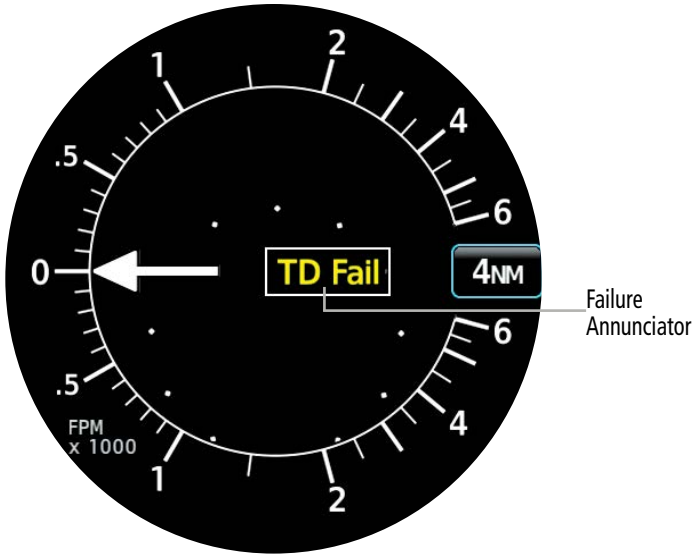

TD Failure Annunciations

- System Overview
- Flight Instruments
- EIS
- Navigation
- Hazard Avoidance
- Autopilot
- IVSI**
- Additional Features
- Appendices
- Index

SECTION 8 ADDITIONAL FEATURES

8.1 OVERVIEW

Additional features of the GI 275 Multi-Function Instrument (MFI) include the following:

- SafeTaxi®
- Radar Altimeter (Optional)
- Flight Data Logging
- Garmin Pilot Watch Connectivity (Optional)
- Synthetic Vision Technology (Optional)
- ADI and HSI Misc. Field (Optional)
- Transponder Control

SafeTaxi® diagrams provide detailed taxiway, runway, and ramp information at more than 1,000 airports in the United States.

The optional Radar Altimeter feature on the MFI displays the height above terrain in real-time, directly below the aircraft by using compatible hardware.

The Flight Data Logging feature automatically connects and stores critical flight and engine data to Garmin Pilot through Connex or to a USB device through Garmin's proprietary GSB 15. Approximately 1,000 flight hours can be recorded for each 1GB of available space.

The optional Garmin Pilot Watch can connect to the MFI using a Bluetooth Low Energy (BLE) network. This connection establishes a real-time data transfer of flight information from the aircraft to the Garmin Pilot Watch.

The optional Synthetic Vision Technology (SVT™) depicts a forward-looking attitude display of the terrain and traffic immediately in front of the aircraft on the 'ADI' Page.

The ADI and HSI Misc. Field can be configured to display True Airspeed (TAS), Ground Speed (GS), Air Temperature (OAT, ISA, TAT), or Wind (Direction and Velocity).

8.2 SAFETAXI®



WARNING: Do not use SafeTaxi® information as the primary method of flight guidance during ground operations. SafeTaxi® does not have NOTAM or ATIS information regarding the current active runway, condition, or complete information about the position of hold lines.



NOTE: With the availability of SafeTaxi®, it is still advisable to carry another source of charts on board the aircraft.

SafeTaxi[®] is an enhanced feature that provides greater map detail when viewing airports at close range on the 'HSI Map' or 'Map' Page. Map options are configurable. When SafeTaxi is enabled, the map reveals taxiways with identifying letters/numbers, airport Hot Spots, and airport landmarks including ramps, buildings, control towers, and other prominent features. SafeTaxi[®] features default to being viewed at or less than 1 nm and can be configured out to 5 nm. Resolution is greater at lower map ranges.

When the aircraft's current position is within the SafeTaxi[®] view, the airplane / rotorcraft symbol on the airport provides enhanced position awareness. If configured, SafeTaxi information is always displayed on the 'HSI Map' Page depending on map range and detail level. SafeTaxi information may be displayed on the 'Map' Page at the pilot's discretion, by enabling/disabling and changing the range display settings.

Configuring SafeTaxi[®] Range:

- 1) From the 'Map' Page, open the menu and select **Map Options > Aviation Options**.
- 2) Scroll down and select **SafeTaxi RNG**.
- 3) Choose a range (e.g., **1NM**, **2NM**, or **5NM**), then select **Back** three times to return to the 'Map' Page.



NOTE: When obstacles are displayed on the Navigation Map in the vicinity of an airport being viewed with SafeTaxi[®], the obstacle symbols may be obscured by SafeTaxi[®] feature labels.

Designated Hot Spots are recognized at airports with many intersecting taxiways and runways, and/or complex ramp areas. Airport Hot Spots are outlined to caution pilots of areas on an airport surface where positional awareness confusion or runway incursions happen most often. Hot Spots are defined with a magenta circle or outline around the region of possible confusion.

Obtaining additional SafeTaxi[®] Hot Spot info from the MFI:

- 1) From the 'Map' Page, touch a magenta Hot Spot. A description appears above the Hot Spot (e.g., 'RUNWAY/TAXIWAY INTERSECTION,' 'COMPLEX INTERSECTION,' etc.). The **Hot Spot Info** Button also appears at the bottom of the MFI.
- 2) Touch the **Hot Spot Info** Button to reveal the 'Hot Spot Info' Page.

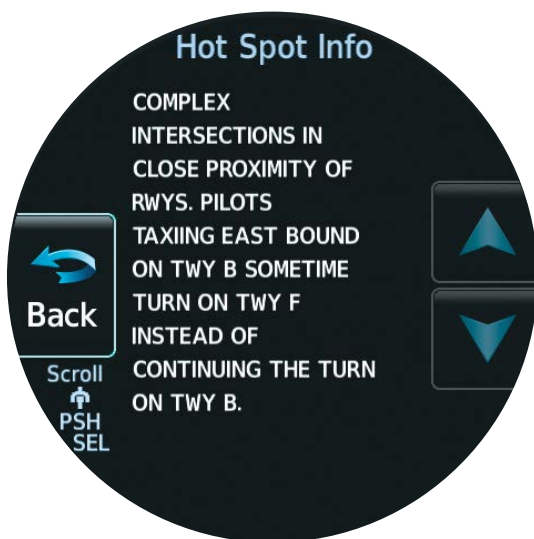

Hot Spot Info

During ground operations the aircraft's position is displayed in reference to taxiways, runways, and airport features. In the example shown, the aircraft is on runway 19R approaching a designated Airport Hot Spot boundary at KSFO airport.

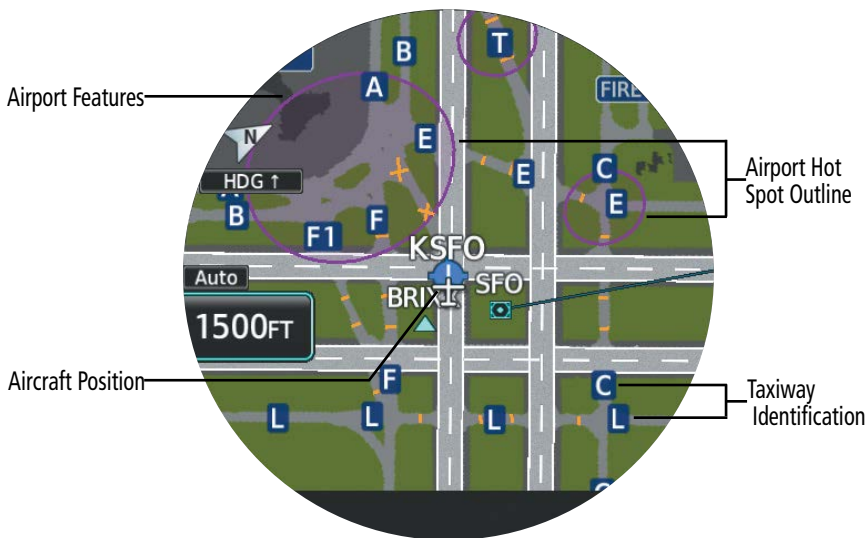

SafeTaxi® - 'Map' Page

Removing SafeTaxi® information from the 'Map' Page:

From the 'Map' Page, open the menu and select **Map Options > Aviation Options > SafeTaxi**. A subdued indication on the **SafeTaxi** Button indicates the feature is disabled. A green indication signifies the feature is enabled.

Or:

- 1) From the 'HSI Map' Page or the 'Map' Page, open the menu and select **HSI Map Options/Map Options > Map Options > Map Detail**.
- 2) Select the lowest level of map detail.

8.3 RADAR ALTIMETER (OPTIONAL)

OVERVIEW

The optional Radar Altimeter (Rad Alt) display on the MFI displays the height above terrain in real-time, directly below the aircraft. The Rad Alt is not forward looking and the AGL reading is not a good indication of future AGL altitudes. The MFI uses Garmin or compatible hardware to measure height AGL by timing how long it takes a radio beam to reflect off the ground and return to the aircraft. Thus, when airborne, the radar altitude reading is constantly changing as terrain changes.

When above 2,500' AGL, the Rad Alt indicator pointer is removed. When descending below 2,500' AGL, the indicator pointer will come alive and indicate radar height above ground level.



Airborne Radar Altimeter

- System Overview
- Flight Instruments
- EIS
- Navigation
- Hazard Avoidance
- Autopilot
- WSI
- Additional Features
- Appendices
- Index

Fixed Wing Configuration

Setting the Radar Altimeter Decision Height (DH):



NOTE: The DH visual alert will not occur unless the aircraft is airborne.



NOTE: Once the aural alert has been triggered, it will be suppressed until a 200' difference between the selected DH value and current height.

From the 'Rad Alt' Page, turn the Small Knob to increase or decrease the DH.

Or:

- 1) From the 'Rad Alt' Page, touch the **DH** Button.
- 2) Enter the desired height using the numeric keypad.
- 3) Touch the **Enter** Button.

When the aircraft is airborne and descends through the set DH, a yellow 'DH' annunciation illuminates, the digital AGL altitude becomes yellow, the DH bug becomes yellow, and the aural alert, "Minimums, Minimums" sounds.

| Standard | | Metric | |
|--|-------------------|-----------------|---------------------|
| Height (Feet) | Resolution (Feet) | Height (Meters) | Resolution (Meters) |
| < 200 | 5 | < 60 | 1 |
| 200 - 1500 | 10 | 60 - 460 | 5 |
| 1501 - 2500 | 50 | 461 - 760 | 20 |
| Fixed Wing Radar Altimeter Resolution | | | |

- System Overview
- Flight Instruments
- EIS
- Navigation
- Hazard Avoidance
- Autopilot
- WSI
- Additional Features
- Appendices
- Index



Airborne Indications - Below Decision Height - Fixed Wing

Rotorcraft Configuration

Setting the Radar Altimeter Decision Height (DH):



NOTE: The DH visual alert will not occur unless the aircraft is airborne.



NOTE: Once the aural alert has been triggered, it will be suppressed until a 20' difference between the selected DH value and current height.

From the 'Rad Alt' Page, turn the Small Knob to increase or decrease the DH.

Or:

- 1) From the 'Rad Alt' Page, touch the **DH** Button.
- 2) Enter the desired height using the numeric keypad.
- 3) Touch the **Enter** Button.

When the aircraft is airborne and descends through the set DH, a yellow 'DH' annunciation illuminates, the digital AGL altitude becomes yellow, the DH bug becomes yellow, and the aural alert, "Decision Height" sounds.

A 100' aural callout can be enabled. If configured, anytime the radar altitude passes through 100', an aural "one-hundred feet" or "thirty meters" will sound. This can be muted either by opening the menu, selecting radar altimeter options, then selecting **RA Mute**, or if a discrete switch is installed, then activating the switch.

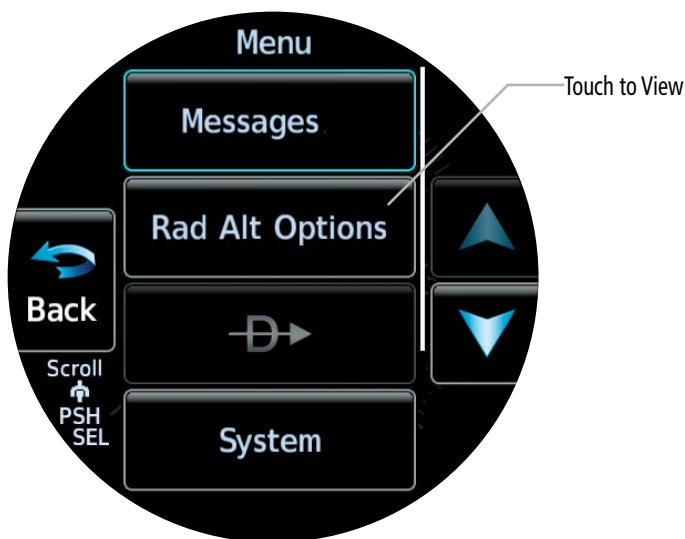

Menu - Radar Altimeter Options

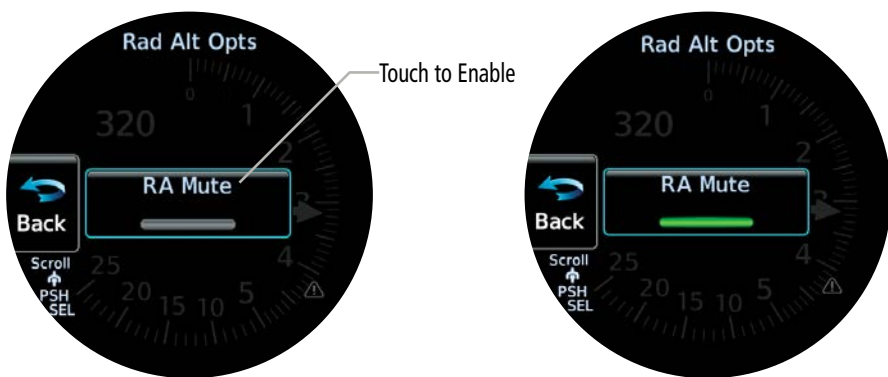

Menu - Radar Altimeter Options - RA Mute - Enabled

| Standard | | Metric | |
|---------------|-------------------|-----------------|---------------------|
| Height (Feet) | Resolution (Feet) | Height (Meters) | Resolution (Meters) |
| < 50 | 1 | < 16 | 1 |
| 50 - 200 | 5 | 16 - 60 | 2 |
| 201 - 2500 | 10 | 61 - 760 | 5 |

Rotorcraft Radar Altimeter Resolution

- System Overview
- Flight Instruments
- EIS
- Navigation
- Hazard Avoidance
- Autopilot
- IVSI
- Additional Features
- Appendices
- Index

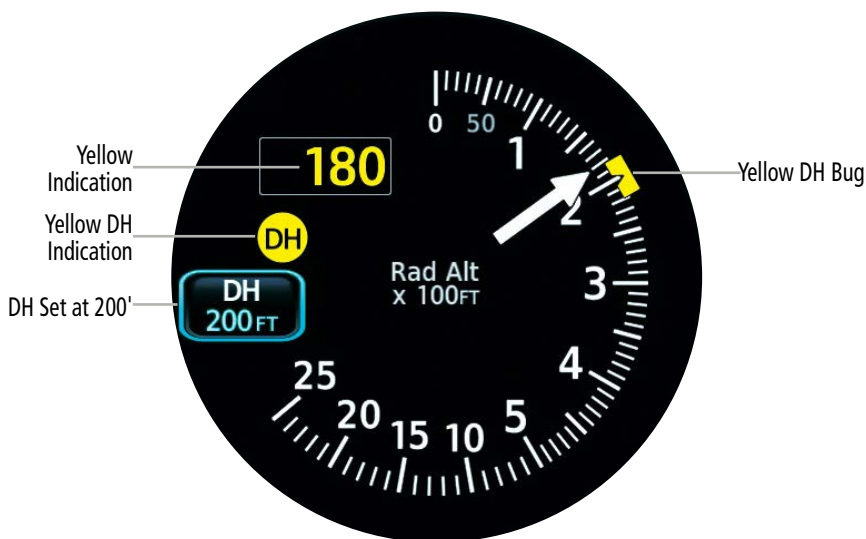

Airborne Indications - Below DH - Rotorcraft

RADAR ALTIMETER TEST



NOTE: The Rad Alt Test is not applicable to all external radar altimeters. If N/A, the MFI will not display the option to run the Rad Alt Test.



NOTE: The Radar Altimeter Test is only available while on the ground.

This purpose of this feature is to test the communication between the MFI and an external radar altimeter. Refer to the hardware's pertinent manual for external radar altimeter hardware testing.

During the test, the annunciation 'RA TEST' is present and a predetermined height is displayed (e.g., 50'). If the test fails, the Rad Alt will display 0' throughout the test where 50' is expected to be displayed otherwise.

Testing the Radar Altimeter:

- 1) From the 'Rad Alt' Page Menu, select **Rad Alt Options**.
- 2) Select **Test** to initiate the Rad Alt Test.

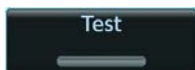

- 3) Note the following indications during the test:
 - a) The annunciation 'RA TEST' illuminates.
 - b) The pointer rises to 50' and then falls back to 0'.

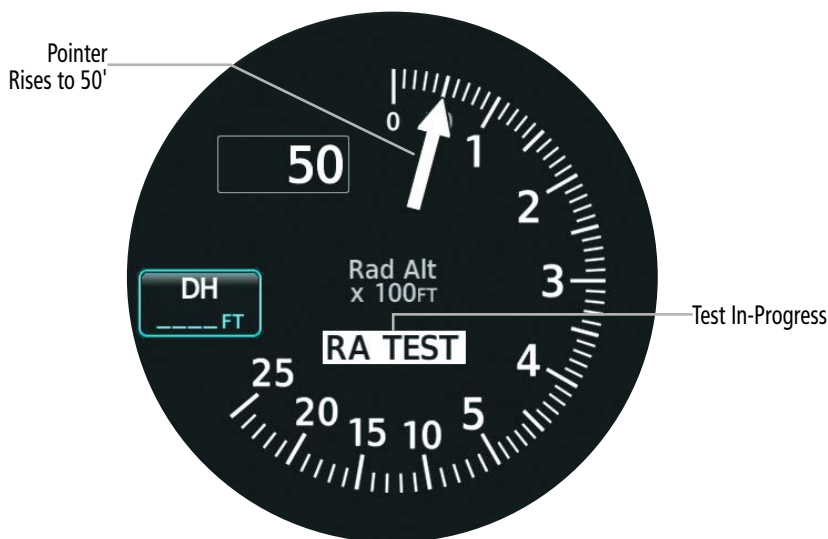

Ground Rad Alt Test

8.4 FLIGHT DATA LOGGING

The Flight Data Logging feature automatically connects and stores critical flight and engine data to Garmin Pilot through Connex or to a USB device through Garmin's proprietary GSB 15. Data is recorded once each second while the power is applied to the system.

WIRELESS FLIGHT DATA LOGGING WITH CONNEX

For registration and connection instructions, see the applicable sections in System Overview.

Wireless Flight Data Logging is enabled through Garmin Pilot and utilizes Connex. The Flight Data Log is attached to your logbook entry and saved to flygarmin.com for future analysis. While Garmin Pilot is running, the Flight Data Log is continuously streamed to your Portable Electronic Device (PED). For the Flight Data Log to be available upon landing, Garmin Pilot must be running for the duration of the flight.

EXPORTING FLIGHT DATA WITH A USB DRIVE

When a USB device is inserted into the optional GSB 15, flight data is automatically recorded throughout the flight. Approximately 1,000 flight hours can be recorded for each 1GB of available space on the USB device.



NOTE: It is recommended to use a USB thumbdrive no larger than 32 GB. The USB may not be detected for up to one minute after the GI 275 is powered On. If the USB is inserted after one minute, detection of the USB and it's databases may take up to 15 seconds.

Exporting Aircraft Reports/Flight Data Logs to a USB drive:

- 1) Insert a USB drive into the optional GSB 15 or the USB dongle on the back of the MFI.
- 2) From any page, open the menu and select the **System > Export Logs** Button.
- 3) Select **All** or the desired date range with the **Export Log Filter** Button, then select **Start Export**. The MFI begins the export process. The export is complete when the MFI displays "Complete 100.00%."

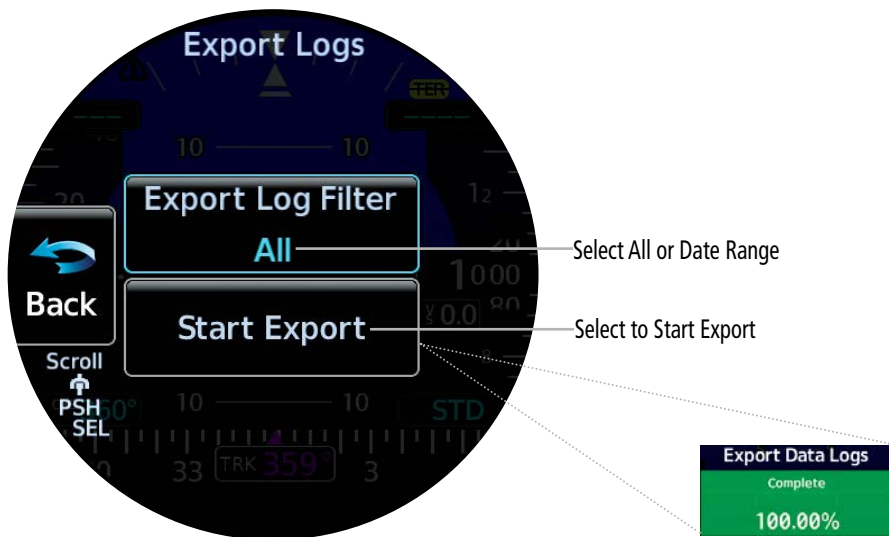
**Export Logs**

All flight data logged on a specific date is stored in a file named in a format which includes the date, time, and nearest airport identifier.

DATA PARAMETERS

NOTE: Some aircraft installations may not provide all aircraft/engine data capable of being logged by the system.

- System Overview
- Flight Instruments
- IS
- Navigation
- Hazard Avoidance
- Autopilot
- IVSI
- Additional Features
- Appendices
- Index

The following is a list of data parameters the system is capable of logging.

- Local Date
- Local Time
- UTC Offset (HH:MM)
- Latitude (deg.)
- Longitude (deg.)
- Active Wpt. Identifier
- Active Wpt. Distance (nm)
- Active Wpt. Bearing (deg.)
- Voltage 1 (volts)
- Voltage 2 (volts)
- Amps 1 (amps)
- Amps 2 (amps)
- AFCS On/Off Status
- AFCS Roll/Pitch Modes
- AFCS Roll/Pitch Commands
- Fuel Qty (R, L, & Ctr)(gals)
- Aux Fuel Qty (1 & 2)
- Baro Altitude (ft.)
- Pitch/Roll (deg.)
- Indicated Airspeed (kts)
- True Airspeed (knots)
- OAT (deg. C)
- Pressure Altitude (ft.)
- Altimeter Setting (in. Hg.)
- GPS altitude (WGS84 datum)
- Vertical Speed (fpm)
- Vertical Speed Selected (fpm)
- Ground Speed (kts)
- Ground Track (deg. mag.)
- Magnetic Heading (deg.)
- Magnetic Variation (deg.)
- HSI Sel. (GPS 1/2, NAV 1/2)
- Selected Course (deg.)
- CDI deflection
- Nav 1/Nav 2 Frequency
- Com1/Com2 frequency
- Lateral Acceleration (g)
- Normal Acceleration (g)
- GPS Fix (e.g., 2D, 3D, 3DDiff)
- Horizontal Alert Limit (m)
- Vertical Alert Limit (m)
- Horiz. Protection Level (m)
- Vertical Protection Level (m)
- Wind Speed (kts)
- Wind Direction (deg.)
- Fuel Flow (gph)
- Fuel Pressure (psi)
- Oil Temperature (deg. F)
- Oil Pressure (psi)
- Manifold Pressure (inHG)
- Engine Speed (rpm)
- EGT #1-6 (deg. F)
- TIT #1/#2
- CHT #1-6 (deg. F)
- CHT Cooling (deg. F)
- Carb. Temp. (deg. F)
- Induction Air Temp (deg. F)
- CDT (deg. F)
- Primary EGT (deg. F)

The file containing the recorded data will appear in the format shown in the following figure. The .csv file may be viewed with Microsoft Excel[®] or other spreadsheet applications.

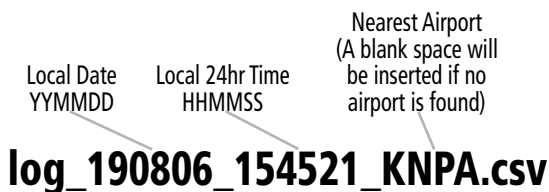

Log File Format

8.5 GARMIN PILOT WATCH CONNECTIVITY (OPTIONAL)

The Garmin Pilot Watch can be connected to the MFI through a Bluetooth Low Energy (BLE) network. Once connected, the following information is sent real-time to the Garmin Pilot Watch:

- Indicated Airspeed (IAS)
- True Airspeed (TAS)
- Vertical Speed
- Pressure Altitude
- Wind Speed
- Wind Direction
- Outside Air Temperature (OAT)
 - Static and Total
- Height Above Terrain (HAT)
- Density Altitude

The Garmin Watch must be 'paired' with the MFI in order to use the various functions. Pairing is accomplished once for each device. After the initial pairing, with 'Auto-Reconnect' enabled, your Garmin Watch will automatically reconnect with the MFI. The pairing operation is completed from the Garmin Watch and the MFI. The MFI can connect three Bluetooth devices and one BLE device. For Garmin Watch specific instructions, see the Garmin Pilot Owner's Manual.



NOTE: *The aircraft must be on the ground to pair the Garmin Pilot Watch.*



NOTE: *The wireless card on the MFI may take up to two minutes after startup before wireless functionality is available.*

Pairing the Garmin Watch with the MFI:

- 1) Place the Garmin Watch in pairing mode. Reference the operating manual for the Garmin Watch for detailed pairing instructions.
- 2) On the MFI, open the menu and select **System > Wireless**.
- 3) Scroll down and select **Pair a Device**. On the 'Pair Device' Screen, the MFI will display its Bluetooth name and prompt the pilot to "Please remain on this page while pairing your Bluetooth device."

Pair a Device

- Once the MFI receives the pairing request from the Garmin, a pairing message will prompt the pilot. Press the **Pair** Button. After the connection is established, the Garmin Watch will show 'Status Connected.'

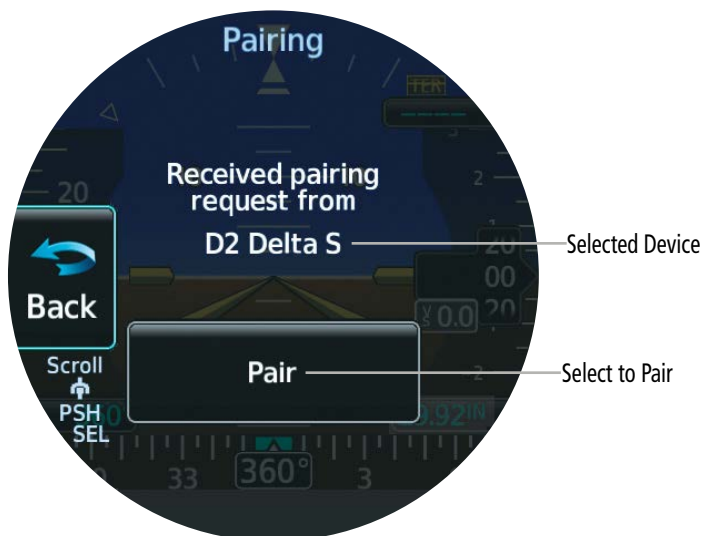

Pairing Request Received

You may use the following procedure to view the connection on the MFI.

Viewing connected devices:

- Open the menu and select **System > Wireless**.
- Scroll down and select **Bluetooth Devices**.
- A list of devices is displayed on the next screen. Select your connected device. See the following image.
- In the following example, the watch's name is 'D2 Delta S' and its status is 'Online.' Additionally, note the connected devices' MAC Address. Use this information to confirm the D2™ is connected and online.



NOTE: It is not uncommon for the status of a BLE device, such as the D2™ Watch, to announce 'Status Offline' and still function properly. This is a feature of BLE reduced power consumption and alternating status is expected.

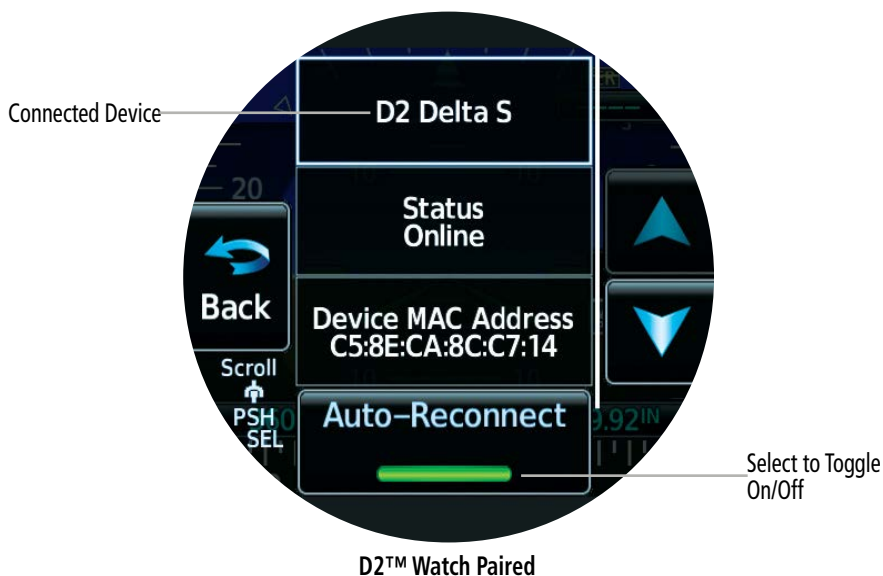

Enabling/disabling automatic reconnection of a paired device:

- 1) Open the menu and select **System > Wireless > Bluetooth Devices**.
- 2) A list of devices is displayed on the next screen. Select your connected Garmin Pilot Watch.
- 3) Note in the above image, the device by default is configured to automatically reconnect (green annunciator is illuminated).
- 4) Select the **Auto-Reconnect** Button to disable the automatic reconnection functionality (green annunciator is not illuminated).

Removing a paired device:

- 1) Open the menu and select **System > Wireless > Bluetooth Devices**.
- 2) A list of devices is displayed on the next screen. Select your connected Garmin Pilot Watch.
- 3) Scroll down and select the **Remove Device** Button to remove the selected Garmin Pilot Watch from the MFI.

8.6 SYNTHETIC VISION TECHNOLOGY (SVT™) (OPTIONAL)



WARNING: Use appropriate primary systems for navigation, and for terrain, obstacle, and traffic avoidance. Garmin SVT™ is intended as an aid to situational awareness only and may not provide either the accuracy or reliability upon which to solely base decisions and/or plan maneuvers to avoid terrain, obstacles, or traffic.



NOTE: When configured as a Primary ADI, a half screen menu is available and individual page options are accessed through the generic Options Button. When configured as a Standby ADI or MFD, a full screen menu is available and individual page options are accessed through the ADI Options Button on the 'ADI' Page Menu.



NOTE: A free trial for SVT is configured for the first 660 minutes of flight time. Trial status and time remaining may be viewed by opening the SVT Options menu from the 'ADI' Page.

The optional Synthetic Vision Technology (SVT™) depicts a forward-looking attitude display of the topography immediately in front of the aircraft on the 'ADI' Page. Displayed pitch range on the attitude indicator changes based on whether SVT is displayed. The depicted imagery is derived from the aircraft attitude, heading, GPS three-dimensional position, and a 9.9 arc-second database of terrain, obstacles, and other relevant features. SVT will not display without a valid GPS position. The terrain data resolution of 9.9 arc-seconds, meaning that terrain elevation contours are stored in squares measuring 9.9 arc-seconds on each side, is required for the operation of SVT. Loss of any of the required data, including temporary loss of the GPS signal, will cause SVT to be disabled until the required data is restored.

The terrain display is intended for situational awareness only. It may not provide the accuracy or fidelity on which to base decisions and plan maneuvers to avoid terrain or obstacles. Navigation must not be predicated solely upon the use of the synthetic terrain or obstacle data displayed by SVT.



Synthetic Vision Display

Activating and deactivating SVT:

- 1) From the 'ADI' Page, open the menu and select **ADI Options > Terrain SVT**.
- 2) Select the **Synthetic Terrain** Button to toggle SVT depiction.

SVT FEATURES

Flight Path Marker

The Flight Path Marker (FPM), also known as a Velocity Vector, is displayed at groundspeeds above 30 knots. The FPM depicts the approximate projected path of the aircraft accounting for wind speed and direction relative to the three-dimensional terrain display. The FPM is always available when the Synthetic Terrain feature is in operation. The FPM represents the direction of the flight path as it relates to the terrain and obstacles on the display, while the aircraft symbol represents the aircraft heading. There can be instances where the flight path marker 'pegs' on a side of the display, indicating the FPM, would have continued off-screen. This is represented by the FPM changing from solid lines to dotted lines. The FPM may also be used to identify a possible conflict with the aircraft flight path and distant terrain or obstacles. Displayed terrain or obstacles in the aircraft's flight path extending above the FPM could indicate a potential conflict, even before an alert is issued by TAWS/Terrain-FLTA. However, decisions regarding terrain and/or obstacle avoidance should not be made using only the FPM.



Flight Path Markers

Zero-Pitch Line

The Zero-Pitch Line is drawn completely across the ADI and represents the horizon when the terrain horizon is difficult to distinguish from other terrain being displayed. It may not align with the terrain horizon, particularly when the terrain is mountainous or when the aircraft is flown at high altitudes.

Horizon Headings

The Horizon Heading is synchronized with the HSI and shows compass heading labeled in 30 degree increments on the Zero-Pitch Line with tick marks every 10 degrees. Horizon Heading tick marks and digits appearing on the zero-pitch line are not visible behind the symbolic aircraft, airspeed, or altitude display. Horizon Heading is used for general heading awareness.

Activating and deactivating Horizon Headings:

- 1) From the 'ADI' Page, open the menu and select **ADI Options > Terrain SVT > Settings**.
- 2) Select the **Horizon Headings** Button to toggle horizon heading depiction.

Airport Signs

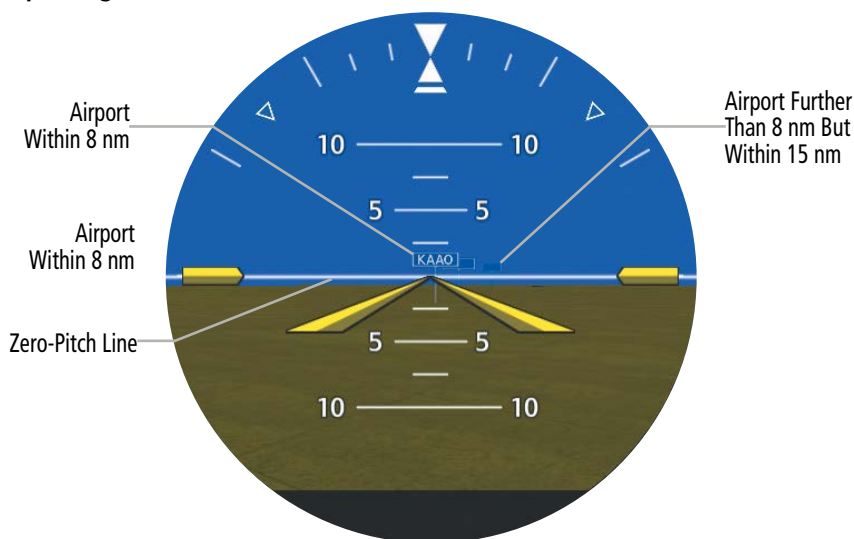

Synthetic Vision - Airport Signs

Airport Signs provide a visual representation of airport location and identification on the synthetic terrain display. When activated, the signs appear on the display when the aircraft is approximately 15 nm from an airport and disappear at approximately 4.5 nm. Airport signs are shown without the identifier until the aircraft is approximately 8 nm from the airport. Airport signs are not shown behind the airspeed or altitude display.

Activating and deactivating Airport Signs:

- 1) From the 'ADI' Page, open the menu and select **ADI Options > Terrain SVT**.
- 2) Select the **Settings** Button.
- 3) Select the **Airport Signs** Button to toggle airport sign depiction.

Airport Runways

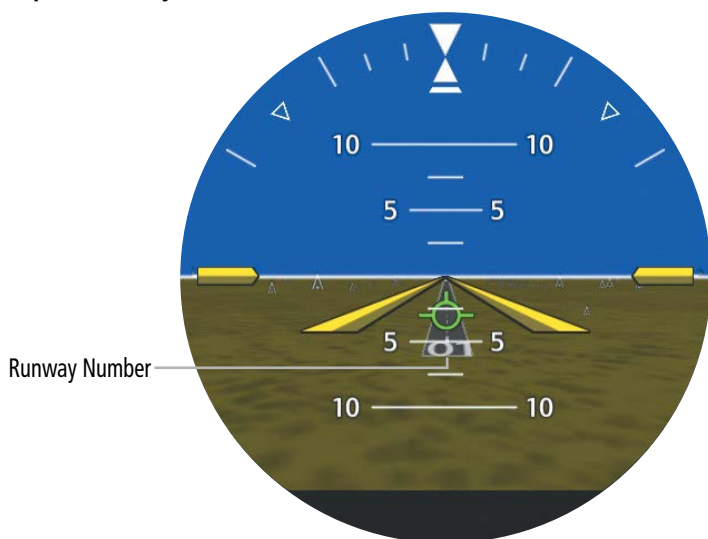

Synthetic Vision - Airport Runway



WARNING: Do not use the Garmin SVT runway depiction as the sole means for determining the proximity of the aircraft to the runway or for maintaining the proper approach path angle during landing.



NOTE: Not all airports have runways with endpoint data in the database; therefore, SVT does not display these runways.

Runway data provides improved awareness of runway location with respect to the surrounding terrain. All runway thresholds are depicted at their respective elevations as defined in the database. In some situations, where threshold elevations differ significantly, crossing runways may appear to be layered. As runways are displayed, those within 45 degrees of the aircraft heading are displayed in white. Other runways will be gray in color. When an approach for a specific runway is active, that runway will appear brighter and be outlined with a white box, regardless of the runway orientation as related to aircraft heading. As the aircraft gets closer to the runway, more detail such as runway numbers and centerlines will be displayed.

Terrain and Obstacle Alerting

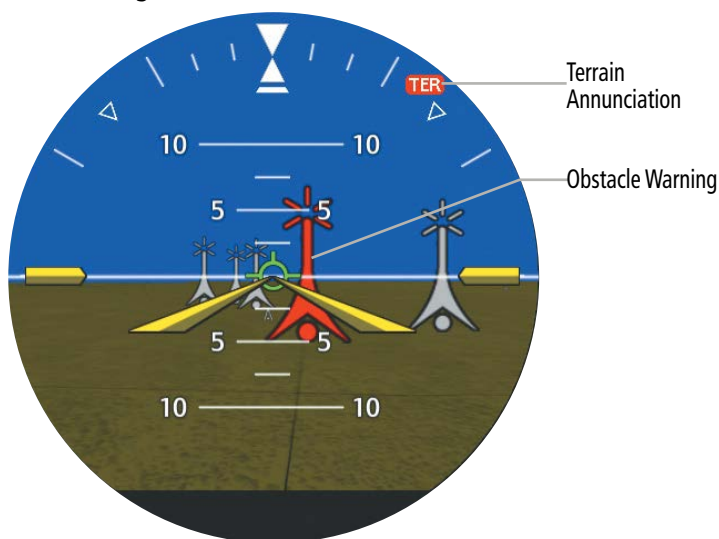

Synthetic Vision - Obstacle Warning and Terrain Caution

Terrain alerting on the synthetic terrain display is triggered by Forward-looking Terrain Avoidance (FLTA) alerts and corresponds to the yellow terrain shading for a caution alert and the red shading for a warning alert. For more detailed information regarding Terrain functions, refer to the Hazard Avoidance Section.

In some instances, a terrain or obstacle alert may be issued with no conflict shading displayed on the synthetic terrain. In these cases, the conflict is outside the SVT field of view to the left or right of the aircraft.

Obstacles are represented on the synthetic terrain display by standard two-dimensional tower or wind turbine symbols found on the navigation maps and charts. Obstacle symbols appear in the perspective view with relative height above terrain and distance from the aircraft. Unlike the moving map display, obstacles on the synthetic terrain display do not change colors to warn of potential conflict with the aircraft's flight path until the obstacle is associated with an actual FLTA alert. Obstacles greater than 1,000 feet below the aircraft altitude are not shown. Obstacles are shown behind the airspeed and altitude displays.

System Overview

Flight Instruments

EIS

Navigation

Hazard Avoidance

Autopilot

WSI

Additional Features

Appendices

Index

Traffic

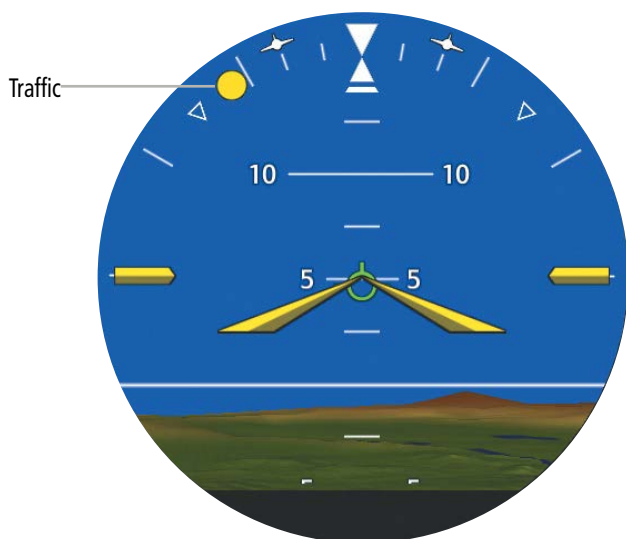

Synthetic Vision - Traffic Display



NOTE: Intruder aircraft at or below 500 ft. AGL may not appear on the SVT display or may appear as a partial symbol.

Traffic symbols are displayed in their approximate locations as determined by the related traffic systems. Traffic symbols are displayed in three dimensions, appearing larger as they are getting closer, and smaller when they are further away. Traffic symbols and coloring are consistent with that used for traffic displayed on the navigation or traffic maps. If the traffic altitude is unknown, the traffic will not be displayed on the SVT display. For more details refer to the traffic discussion in the Hazard Avoidance Section.

SVT TROUBLESHOOTING

Garmin SVT™ is intended to be used with traditional attitude, heading, obstacle, terrain, and traffic inputs. SVT is disabled when valid attitude or heading data is not available for the display. In case of invalid SVT data, the display reverts to the standard cyan-over-brown attitude display.

SVT becomes disabled without the following data resources:

- Attitude data
- Heading data
- External GPS position data
- 9.9 arc-second terrain data
- Obstacle data
- TAWS/Terrain-FLTA not available in test mode, or if failed

FLIGHT ID

- 1) While viewing the transponder page, touch the **Flight ID** key.
- 2) Touch the numeric keypad, or use the rotary knobs, to select the desired Flight ID number.
- 3) Touch **Enter** or press the small right knob. The selected Flight ID number will be shown in the Flight ID key.



Flight ID Keypad Entry

- System Overview
- Flight Instruments
- EIS
- Navigation
- Hazard Avoidance
- Autopilot
- WSI
- Additional Features
- Appendices
- Index



Squawk Code Changed

8.7 ADI AND HSI - MISC. FIELD (OPTIONAL)

The Misc. Field on the ADI can be configured to display True Airspeed (TAS), Ground Speed (GS), Air Temperature (OAT, ISA, TAT), Wind (Direction and Velocity), and G-Meter (G).



NOTE: When configured as a "3-in-1" ADI, the GI 275 can display all the Misc. Field parameters on the page. When configured as a "4-in-1" ADI, only one parameter may be displayed on the page.

Displaying True Airspeed:

- 1) From the 'ADI' or 'HSI' Page, open the menu and select **ADI or HSI Options > Misc. Field.**
- 2) Select the **TAS** Button to toggle True Airspeed.

Displaying Ground Speed:

- 1) From the 'ADI' or 'HSI' Page, open the menu and select **ADI or HSI Options > Misc. Field.**
- 2) Select the **GS** Button to toggle Ground Speed.

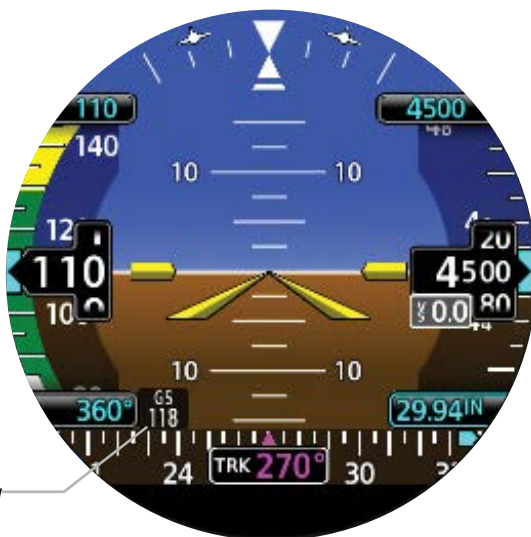

Misc. Field Display

ADI - Misc. Field - Ground Speed Display



Misc. Field Display



HSI - Misc. Field - Ground Speed Display

Displaying Outside Air Temperature:

- 1) From the 'ADI' or 'HSI' Page, open the menu and select **ADI or HSI Options > Misc. Field**.
- 2) Select the preferred temperature option, ISA, OAT, or TAT.

- 3) Select the button to toggle Temperature.

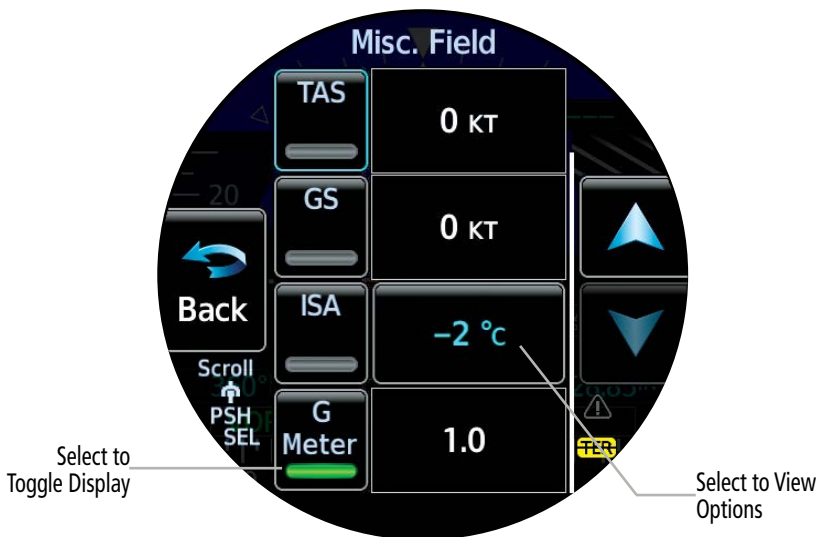

ADI or HSI - Misc. Field - Temperature and G Meter Selection

Displaying Wind:

- 1) From the 'ADI' or 'HSI' Page, open the menu and select **ADI or HSI Options > Misc. Field**.
- 2) Scroll down and select the preferred wind format.

- System Overview
- Flight Instruments
- EIS
- Navigation
- Hazard Avoidance
- Autopilot
- WSI
- Additional Features
- Appendices
- Index

- 3) Select the **Wind** button to toggle Wind.

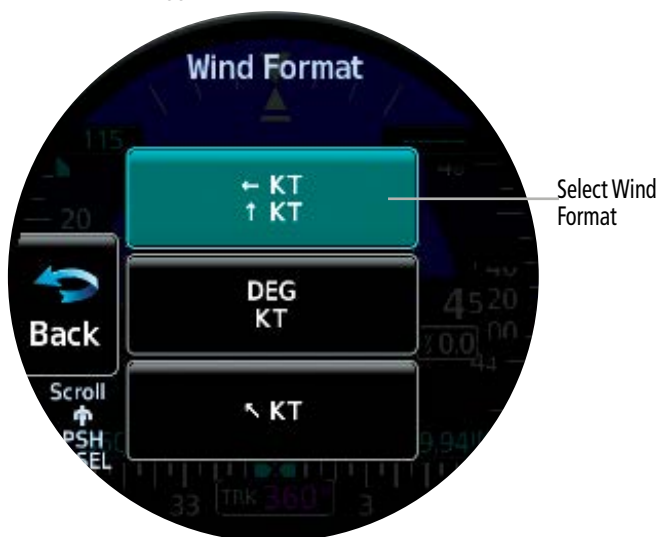

ADI - Misc. Field - Wind Format

8.8 TRANSPONDER CONTROL (OPTIONAL)

The GI 275 can perform the control and display for a remotely mounted GTX 345 transponder functions. See your dealer for more information.

TRANSPONDER OPERATION

The GI 275 will operate as a control head for remotely connected optional GTX 345 transponders.



ADI - Transponder Control Display

SELECT TRANSPONDER

- 1) Touch the **Active** key to activate the desired transponder by stepping through the available transponders.

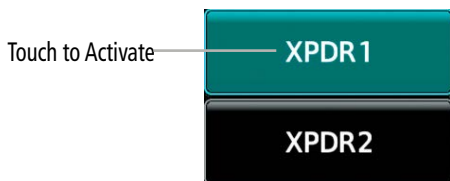

Active Transponder Indication

- 2) The active transponder will be shown on the key.

IDENT

- 1) Touch the **IDENT** key once to reply with an identifying squawk code.



Transponder IDENT Key

- 2) The **IDENT** key will show a green "ID" in the top right corner of the key to indicate an active Ident.

STANDBY

- 1) Touch the **Standby** key to place the transponder into Standby mode. The Transponder will still be powered, but will not transmit information. The active transponder indication and Ident annunciation will be greyed out to show they are disabled.



Transponder "Standby" Indication

ON

Touch the **On** key for Mode A operation. The transponder is "On" and will transmit its squawk code when interrogated.

ALTITUDE REPORTING

- 1) Touch the **Altitude Reporting** key for Mode C operation.
- 2) The transponder will be "On" and will transmit its squawk code and altitude when interrogated. An "ALT" annunciation will appear when the squawk code is transmitted.

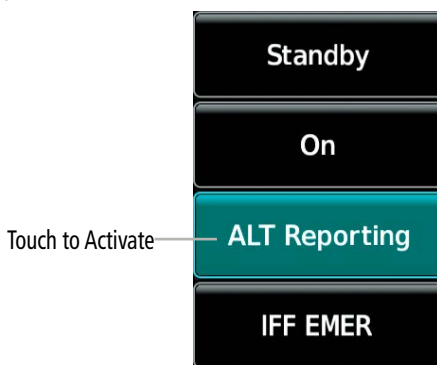

Altitude Reporting Mode Selection

VFR

Touch the **VFR** key to set the VFR squawk code (1200).

Touch to Set VFR Squawk Code



VFR Squawk Code

SELECTING A SQUAWK CODE

The selected squawk code will always be in use. As you change a squawk code, the original code will be used until you are finished selecting the new code.

| Squawk Code | Description |
|---|----------------------------|
| 1200 | Default VFR Code in U.S.A. |
| 7500 | Hijacking |
| 7600 | Loss of Communications |
| 7700 | Emergency |
| Special Transponder Squawk Codes | |

- 1) Touch the transponder squawk code window at the top of the display.
- 2) The XPDR page will be displayed. The Squawk Code value will be active for selection for use by the active transponder.



ADI - Transponder Control Display - Change Squawk Code

- 3) Touch the numeric keypad, or use the rotary knobs, to select the desired Squawk Code.
- 4) Touch **Enter** or press the small right knob.
- 5) The selected Squawk Code will be shown in the XPDR window at the top of the display.



GDL 60 (OPTIONAL)

The GDL 60 provides LTE and Wi-Fi connectivity capabilities to and from an aircraft, allowing the user to view an aircraft's data and location remotely via the Garmin Pilot app on a mobile device.

| Compatible Devices with GDL 60 Datalink PlaneSync Technology | | | |
|--|------------|-----------|-----------|
| G3000 | G700 TXi | GTN 625Xi | GTN 725Xi |
| G500 TXi | GI 275 | GTN 635Xi | GTN 750Xi |
| G600 TXi | GI 275 EIS | GTN 650Xi | TXi EIS |

GDL 60 Compatible Devices

PLANESYNC™

When properly connected and configured with a compatible GTN Xi navigator and select flight decks, the GDL 60 is the datalink that enables the PlaneSync technology, which facilitates the following functionality:

- Automatic database downloads via 4G LTE cellular or Wi-Fi.
- Real-time aircraft status via the Aircraft Dashboard.
- Upload flight plans to a compatible navigator.
- Interface in-flight with portable devices, apps, avionics, a GDL 69A SXM satellite receiver, and a GSR 56 satellite transceiver via Connex services.
- Upon completion of a flight, EIS data and other info are uploaded into cloud storage for review and/or documentation.



REMOTE AIRCRAFT STATUS

With a properly installed, configured, and connected GDL 60, Garmin Pilot will display the Aircraft Dashboard page, which allows the user to check the status of an active/standby database, Hobbs/Tach time, fuel quantity, battery voltage, Outside Air Temperature (OAT), oil temperature, and GPS location of the aircraft.

When Garmin Pilot is paired to the GDL 60, select the **Aircraft** page to view the Remote Aircraft Status.

The screenshot shows the Aircraft Dashboard interface with the following callouts and data:

- Touch to Select Aircraft Last Database Update & Status:** Points to the 'SELECT AIRCRAFT' button on the aircraft image.
- Aircraft Info:** Points to the main data cards:
 - Hobbs: 1000 HRS
 - Tach: 1946.1 HRS
 - Fuel: 90 GAL (45-45)
 - Battery: 28.3 V
 - Oxygen: 1500 PSI
 - TKS: 4 GAL TKS1, 4 GAL TKS2
 - OAT: 70 °F
 - Oil: 81 °F
- Airport Info:** Points to the METAR and KFCM data:
 - METAR: KFCM 10:53 CDT
 - KFCM: FLYING CLOUD
 - Winds: 110°@6k15kt
 - Ceiling: Unlimited
 - Visibility: 10SM
 - Temp/Dew: 66°f / 52°f
 - Altimeter: 29.85IN
- Touch to View in Google Maps:** Points to the map area showing the aircraft position.
- Touch to View:** Points to the 'SHOW DETAILS' button.
- Sync Progress:** Points to the 'PlaneSync' progress indicator.
- Last Sync:** Points to the 'Updated 2 mins ago' text.

Garmin Pilot - Android - Connex Page - GDL 60 - Aircraft Dashboard

LS ONLY CONFIGURATION (OPTIONAL)

When properly configured and equipped, the ADI can display an ILS Only viewpoint. When flying the front course, an 'ILS' will be displayed, along with the vertical deviation bars. If there is no valid glideslope data, 'NO GS' will be displayed. When flying the back course in the ILS Only configuration, the ADI will display 'BC' for Backcourse.

To switch between ILS and BC modes, touch the corresponding button, ILS or BC, then press the knob. This will allow for normal sensing on the appropriate front course or back course.



ADI - ILS Only Configuration - GS & Localizer

- System Overview
- Flight Instruments
- EIS
- Navigation
- Hazard Avoidance
- Autopilot
- WSI
- Additional Features
- Appendices
- Index

SECTION 9 APPENDICES

APPENDIX A: ANNUNCIATIONS, ALERTS AND GLOVE QUALIFICATION

The following types of annunciations and alerts can be displayed:

- Alert Annunciations
- Message Alert Indicator
- System Messages and Advisory Alerts

ALERT LEVEL DEFINITIONS

Alert Annunciations vary in color and type depending on the alert level. The annunciation is displayed in text form on the pertinent page. If an alert is issued, and the corresponding page is not currently displayed, a pop-up alert will be generated. Additionally, the corresponding gauge or indicator may change color. If a major component of the instrument system has failed, a red or yellow 'X' may be displayed.

The instrument may also issue audio alert tones or voice alerts when specific conditions are met. For function specific aural alerts, see the function's corresponding section of this guide for more information.

EIS Alerts are displayed in the Annunciation Banner on all EIS Pages. For more information on EIS Alerts, see the EIS Alerts discussion in the EIS Section.

Alerting levels are defined below in order of priority:

- **Warning:** This level of alert requires immediate pilot attention. A warning alert is annunciated in red text and depending on the alert, may be accompanied by an aural alert.
- **Caution:** This level of alert indicates the existence of abnormal conditions on the aircraft that may require pilot intervention. A caution alert is annunciated in yellow text and may be accompanied by an aural alert.
- **Advisory:** This level of alert provides general information to the pilot. A message advisory alert is annunciated in white text.

- System Overview
- Flight Instruments
- EIS
- Navigation
- Hazard Avoidance
- Autopilot
- WSI
- Additional Features
- Appendices
- Index

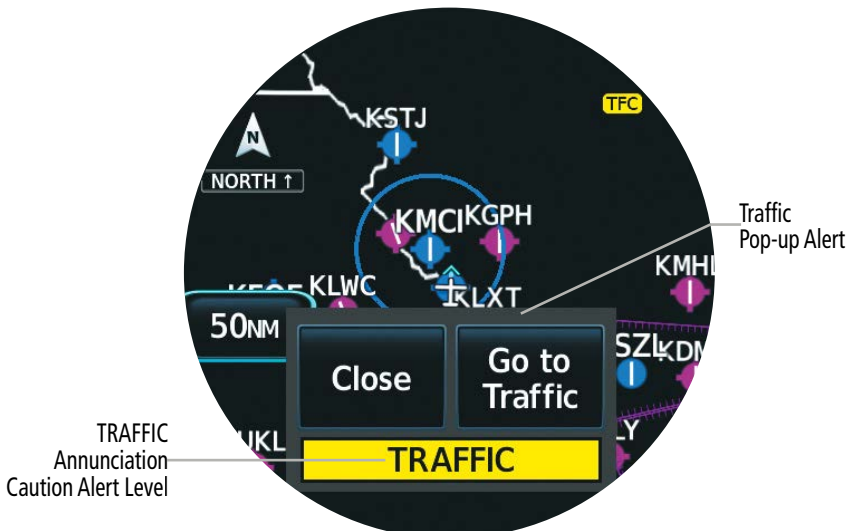

Example Pop-Up Alert

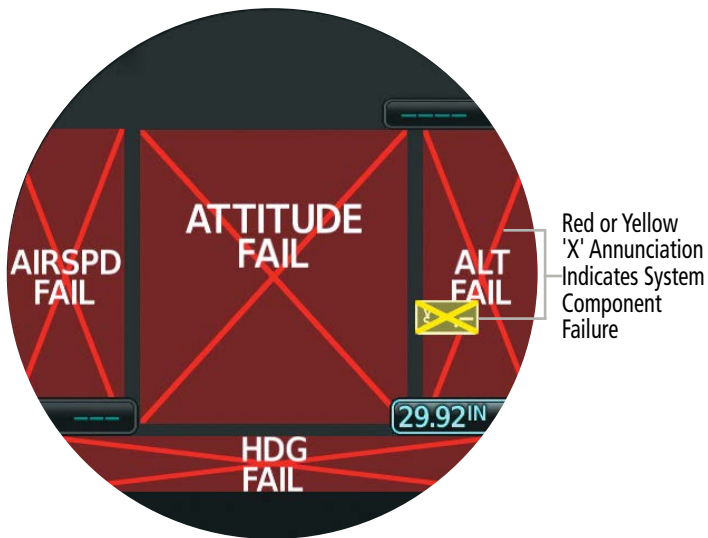

Example of Failure Annunciations

SYSTEM MESSAGES

The following alphabetized table lists the various System Messages.



CAUTION: Do not allow repairs to be made by anyone other than an authorized Garmin service center. Unauthorized repairs or modifications could void both the warranty and affect the airworthiness of the aircraft.



NOTE: Refer to the current, pertinent flight manual for operational conditions and alert/advisory corrective procedures.

| Message | Description |
|--|--|
| 1090ES traffic receiver fault | ADS-B LRU reports that it is unable to receive 1090 Extended Squitter traffic |
| ADC 1/2/3 MISCOMPARE Or ADC MISCOMPARE | ADC data from one or more units is not within tolerances of the other ADC units |
| ADC 1/2/3 MISSING Or ADC MISSING | ADC data from one or more units is missing |
| ADS traffic alerting inoperative | ADS-B LRU reports CSA/TSAA failure |
| ADS traffic function inoperative | The ADS-B LRU reports a traffic alerting failure |
| ADS-B In traffic source mismatch | Unit has received ADS-B traffic from a source other than the configured ADS-B traffic source |
| AHRS 1/2/3: Magnetic model outdated | While on the ground, any interfaced AHRS reports magnetic model out of date; magnetic model database needs to be updated |
| AHRS 1/2/3 MISCOMPARE Or AHRS MISCOMPARE | AHRS data from one or more units is not within tolerances of the other AHRS units |
| AHRS 1/2/3 MISSING Or AHRS MISSING | AHRS data from one or more units is missing |
| AHRS 1/2/3 not receiving GPS aiding | AHRS 1/2 reports not receiving any GPS data, the unit is configured for one or more Garmin SBAS GPS units Or AHRS 3 reports not receiving any GPS data |

| Message | Description |
|--|---|
| Audio inoperative | Audio device failure Or Audio clip failed to play Or Cannot communicate with audio device |
| Backlight calibration lost | While on the ground, the unit cannot read LED calibration data, or is detected as corrupt |
| Battery fault | A battery fault is detected; battery is unavailable |
| Battery unavailable: Capacity test | Battery capacity test if overdue or failed; battery unavailable, capacity test is required |
| Battery unavailable: Communication lost | Battery communication is lost |
| Battery advisory: Charge inhibited | A charge-inhibiting battery fault is detected |
| CHT Cooling | Pilot defined engine advisory limitation exceeded |
| Database SYNC in progress | Database synchronization is in progress; view 'Status' Page for more information |
| EGT Difference | Pilot-specified EGT difference is exceeded by one or more engines |
| GMC ESP inoperative | GMC Electronic Stability Protection has failed |
| GPS 1/2 inoperative | The indicated GPS source failed, or input data not received |
| High BAT voltage | Pilot defined engine advisory limitation exceeded |
| High bus voltage | Pilot defined engine advisory limitation exceeded |
| High CHT | Pilot defined engine advisory limitation exceeded |
| High EGT difference | Pilot defined engine advisory limitation exceeded |
| High oil TEMP | Pilot defined engine advisory limitation exceeded |
| Key stuck: Key knob is stuck | System detects stuck knob(s); the knob is stuck down |
| Low BATT voltage | Pilot defined engine advisory limitation exceeded |
| Low bus voltage | Pilot defined engine advisory limitation exceeded |
| Low EST fuel remaining | Pilot defined engine advisory limitation exceeded |
| Or | Estimated fuel on board or endurance is below the pilot defined limit |
| Low Endurance | |

| Message | Description |
|--|---|
| Low fuel reserve | Pilot defined engine advisory limitation exceeded |
| Low Oil TEMP | Pilot defined engine advisory limitation exceeded |
| <LRU> reports service required | While on the ground, the indicated external LRU reports an internal fault and requires service |
| | While on the ground, external LRU reports service required Or While on the ground, external LRU reports invalid calibration |
| Max Temp Exceeded | Expansion Board has exceeded temperature threshold. |
| NAV 1/2 inoperative | The indicated NAV source is failed, or input data is not received |
| Navigation database expired | Database is expiring imminently or has expired |
| Navigation database not effective yet | Database is not yet active |
| Obstacle database expired | Database is expiring imminently or has expired |
| Obstacle database not effective yet | Database is not yet active |
| Reversionary mode: ADC data missing | Unit is in reversionary mode due to missing ADC data. |
| Reversionary mode: ADC miscompare | Unit is in reversionary mode due to ADC data miscompare. |
| Reversionary mode: AHRS data missing | Unit is in reversionary mode due to missing AHRS data. |
| Reversionary mode: AHRS miscompare | Unit is in reversionary mode due to AHRS data miscompare. |
| System is in Battery Mode | System is operating in battery mode |
| SafeTaxi database expired | Database is expiring imminently or has expired |
| SafeTaxi database not effective yet | Database is not yet active |
| Service required | The system or unit requires service; appears only when the aircraft is on ground |

| Message | Description |
|---|---|
| Service soon | Any interfaced AHRS reports not receiving ADC data |
| | An ADC reports configuration error |
| | Or SSEC is not expected to be configured and an ADC reports that SSEC is configured |
| | While on the ground, interfaced Unit(s) have different software version |
| | SDI check has failed |
| | While on the ground, the configuration CRC of an AHRS or ADC LRU does not match the unit's stored configuration CRC |
| Service soon | While on the ground, Garmin Engine Sensor (e.g., GEA 110, GEA 71B, etc.) Configuration CRC doesn't match unit's saved CRC |
| | The system or unit detects an internal fault but continues to function; appears only when the aircraft is on ground |
| | When on the ground, Stormscope reports invalid heading data |
| SiriusXM receiver inoperative | When on the ground, external LRU reports configuration module needs service |
| | SiriusXM receiver has failed |
| Stormscope inoperative | Or Communication with GDL 69/69A is lost |
| | Stormscope reports failure |
| SVT could not be enabled | Communication with Stormscope is lost |
| SVT Disabled: Low resolution DB | SVT feature could not be unlocked with the unlock provided |
| SVT Disabled: Outside DB coverage | SVT terrain database resolution is insufficient |
| SVT not available due to databases | Outside of SVT Terrain database coverage area |
| SVT successfully enabled | SafeTaxi or Basemap database corrupted or unavailable on ADI |
| SVT Trial 1 hour remaining | SVT feature has been enabled in this power cycle |
| SVT Trial 5 hours remaining | Less than 1 hour of SVT trial remains |
| TAS/TCAS function inoperative | 1-5 Hours of SVT Trial remain |
| | TAS/TCAS device reports traffic fail |
| | Or Communication with TAS/TCAS device is lost |
| | ADS-B LRU reports TAS/TCAS inoperative or connection lost |

| Message | Description |
|---|--|
| TAS/TCAS system in standby | Traffic device reports standby mode for more than 60 seconds while in air |
| | While airborne, ADS-B LRU reports external traffic system has been in standby for more than 60 seconds |
| Terrain not available due to databases | Navigation, Obstacle, or Terrain database corrupted or unavailable on the ADI |
| Traffic function inoperative | TIS-A device reports traffic fail Or Communication with TIS-A device is lost |
| Traffic system in standby | TIS-A device reports standby mode for more than 60 seconds while in air |
| Traffic/FIS-B functions inoperative | UAT receiver capable ADS-B LRU reports electrical fault, calibration data fault, SW CRC Fault, or FPGA CRC Fault |
| | Communication is lost with UAT receiver capable ADS-B LRU |
| UAT fault | The UAT LRU reports a low battery or fan fault |
| UAT traffic/data receiver fault | The ADS-B LRU reports that it is unable to receive UAT traffic and FIS-B data |
| USB and WiFi Unavailable | While on internal battery operation, the unit conserves energy by disabling these functions. |
| VFR GPS is being used | VFR GPS is being used |

System Messages

GLOVE QUALIFICATION



NOTE: *The procedures described in this section should only be performed while the aircraft is on the ground.*

The touchscreen uses capacitive touch technology to sense the proximity of skin to the display. A glove creates a barrier between the skin and the display glass, potentially reducing the ability of the display to detect touches.

This procedure can be used to qualify a glove intended for use with the touchscreen. It is highly recommended to use capacitive touch gloves, as the touchscreen uses capacitive touch technology. Due to differences in finger size, glove size, and touchscreen between the MFI, the qualification procedure is specific to the pilot/glove and MFI combination.

Glove Selection Considerations

Thinner gloves perform better than thicker gloves.

Leather gloves, and gloves designed specifically for use with capacitive touchscreen devices, are often found to be acceptable.

To improve touchscreen sensitivity while wearing gloves, use the pad of the finger instead of the tip during touch interactions.

Glove Qualification Guidance

Checklist 1 entitled "Glove Qualification Steps" on the next page, contains the tasks required to qualify a glove.

Checklist 2 follows Checklist 1, and contains tasks that are not required to qualify a glove, but may limit how some functions are accessed while wearing a glove.

Glove Qualification Steps

Complete only the tasks for the capabilities relevant to the installed MFI.

1. Sit in the pilot's seat.
2. Start the MFI in normal mode.
3. Perform the tasks listed in each checklist, tapping each key with a non-gloved finger. It is not necessary to record any results for this step.
4. Repeat step 3 using a gloved hand.
5. For each task, determine whether the touchscreen response is the same, or worse, without the glove.
6. Record the results in the applicable column. Items that may cause the operation to be worse will include, but are not limited to:
 - Multiple attempts to select a key.
 - Unintentional selection of adjacent key(s).
 - Excessive force on the touchscreen to select a key
7. If all applicable tasks produce the same response, with and without a glove, the pilot may use the glove in flight.

Glove Qualification Procedure

Pilot: _____

Glove Description: _____

| Task | Performance Operation with Glove (Circle One) | |
|---|---|------|
| PFD | | |
| Barometric Setting | | |
| Tap the Baro button (Lower right corner) and rotate the knob to set a different barometric value. Example: 29.96. | Pass | Fail |
| Tap and hold the Baro button for 2 seconds to sync the Baro setting to STD. | Pass | Fail |
| Heading Bug Setting (If configured for 4-in-1) | | |
| Tap the heading button (Lower left corner) and rotate the knob to set a value different than the current. Example 360°. | Pass | Fail |
| Tap and hold the heading button for 2 seconds to sync the heading bug to current heading. | Pass | Fail |
| Preselect Altitude Setting (If the altitude bug is enabled) | | |
| Tap the altitude button (Upper right corner) and rotate the knob to set a value different then the current. Example: 500ft. | Pass | Fail |
| Tap and hold the altitude button for 2 seconds to sync the altitude bug to the current altitude. | Pass | Fail |
| Airspeed Bug Setting (If the Airspeed bug is enabled) | | |
| Tap the airspeed button (Upper left corner) and rotate the knob to set a valid airspeed value. Example: 100kts. | Pass | Fail |
| Tap and hold the airspeed button for 2 seconds to sync the airspeed bug. | Pass | Fail |
| Menu Options | | |
| Swipe from the very bottom of the indicator bezel (Very bottom of the screen) and swipe up to the middle of the screen with a single motion without lifting the finger. | Pass | Fail |
| Scroll the menu to the System options by sliding the finger on the menu from right to left until the System option is in view. | Pass | Fail |
| Select by tapping System . | Pass | Fail |
| Tap the center of the screen to remove the menu. | Pass | Fail |

Glove Qualification Procedures - PFD

| Task | Performance Operation with Glove (Circle One) | |
|---|---|------|
| HSI | | |
| Heading Bug Setting | | |
| Tap the heading button (Lower left corner) and rotate the knob to set a value different than the current. Example 360°. | Pass | Fail |
| Tap and hold the heading button for 2 seconds to sync the heading bug to current heading. | Pass | Fail |
| CDI Selection (If system is configured to enable CDI button) | | |
| Tap the CDI button (Lower center) to select a different CDI source | Pass | Fail |
| CRS Selection (If system is capable of VOR/ILS. CDI source must be set to a Nav source depicting VOR or ILS) | | |
| Tap the CRS button (Lower right corner) and rotate the knob to set a value different than the current. Example 360°. | Pass | Fail |
| Tap and hold the CRS button for 2 seconds to sync the course value to the current heading. | Pass | Fail |
| Menu Options | | |
| Swipe from the very bottom of the indicator bezel (Very bottom of the screen) and swipe up to the middle of the screen with a single motion without lifting the finger. | Pass | Fail |
| Scroll the menu to the System options by sliding the finger on the menu from right to left until the System option is in view. | Pass | Fail |
| Select by tapping System . | Pass | Fail |
| Tap the center of the screen to remove the menu. | Pass | Fail |

Glove Qualification Procedures - HSI

| Task | Performance Operation with Glove (Circle One) | |
|---|---|------|
| EIS (Fixed Wing Only) | | |
| Menu Options | | |
| Swipe from the very bottom of the indicator bezel (Very bottom of the screen) and swipe up to the middle of the screen with a single motion without lifting the finger. | Pass | Fail |
| Scroll the menu to the System options by sliding the finger on the menu from right to left until the System option is in view. | Pass | Fail |
| Select by tapping System . | Pass | Fail |
| Tap the center of the screen to remove the menu. | Pass | Fail |
| Lean (Use knob to select EGT page) | | |
| Tap the Lean button to turn the lean function on (center right). | Pass | Fail |
| Tap the Lean button to turn the lean function off. | Pass | Fail |

Glove Qualification Procedures - EIS

| Task | Performance Operation with Glove (Circle One) | |
|--|---|------|
| MFD | | |
| Map Page (Use knob to select Map page) | | |
| Menu Options | | |
| Swipe from the very bottom of the indicator bezel (Very bottom of the screen) and swipe up to the middle of the screen with a single motion, without lifting the finger. | Pass | Fail |
| Scroll the menu to the System options by sliding the finger on the menu from right to left until the System option is in view. | Pass | Fail |
| Select by tapping System . | Pass | Fail |
| Tap and hold the back button for 2 seconds to remove the menu. | Pass | Fail |
| Range | | |
| Tap the Range button and rotate the knob to change the zoomed range value. | Pass | Fail |
| Pan Mode | | |
| Touch a point on the map and slide across the screen to pan the display. | Pass | Fail |
| Pinch Zoom | | |
| Zoom out, with two fingers, place on the opposite sides of the screen and 'pinch' towards the center. | Pass | Fail |
| Zoom in, with two fingers, place on the center of the screen and slide towards the opposite sides of the screen. | Pass | Fail |

Glove Qualification Procedures - MFD

APPENDIX B: DATABASE INFORMATION



NOTE: The pilot/operator must review and be familiar with Garmin's database exclusion list as discussed in SAIB CE-14-04 to determine what data may be incomplete. The database exclusion list can be viewed at flygarmin.com by selecting 'Database Exclusions List.'



NOTE: The pilot/operator must have access to Garmin and Jeppesen database alerts and consider their impact on the intended aircraft operation. The database alerts can be viewed at flygarmin.com by selecting 'Aviation Database Alerts.'



NOTE: If the pilot/operator wants or needs to adjust the database, contact Garmin Product Support.



NOTE: The FAA has asked Garmin to remind pilots who fly with Garmin database-dependent avionics of the following:

- It is the pilot's responsibility to remain familiar with all FAA regulatory and advisory guidance and information related to the use of databases in the National Airspace System.
 - Garmin equipment will only recognize and use databases that are obtained from Garmin or Jeppesen. Databases obtained from Garmin or Jeppesen that have a Type 2 Letter of Authorization (LOA) from the FAA are assured compliance with all data quality requirements (DQRs). A copy of the Type 2 LOA is available for each applicable database and can be viewed at flygarmin.com by selecting 'Aviation Database Declarations.'
 - Use of a current Garmin or Jeppesen database in your Garmin equipment is required for compliance with established FAA regulatory guidance, but does not constitute authorization to fly any and all terminal procedures that may be presented by the system. It is the pilot's responsibility to operate in accordance with established pertinent aircraft documents and regulatory guidance or limitations as applicable to the pilot, the aircraft, and installed equipment.
-



NOTE: Garmin requests the flight crew report any observed discrepancies related to database information. These discrepancies could come in the form of an incorrect procedure; incorrectly identified terrain, obstacles and fixes; or any other displayed item used for navigation or communication in the air or on the ground. Go to flygarmin.com and select 'Aviation Data Error Report.'

AVAILABLE DATABASES

This section will provide an overview of the databases available on the MFI. Databases may vary depending on the unit configuration (Americas, Atlantic, or Pacific). See the System Overview Section for information on updating databases.

| Databases |
|--|
| Worldwide Basemap |
| Navigation Database (Garmin or Jeppesen [®]) |
| SafeTaxi [®] |
| Obstacle |
| Terrain |

Available Databases

Basemap

The Basemap database contains data for the topography and land features, such as river, lakes, and towns. It is updated only periodically, with no set schedule. There is no expiration date.

Navigation Database

The internal navigation database provides location and facility information for thousands of airports, VORs, NDBs, and more. Updates to the navigation database are available every 28 days online (). There are two navigation database products available: the Garmin Navigation Database or the Jeppesen Navigation Database, which is sourced by Jeppesen.



NOTE: Although the Jeppesen Navigation Database and the Garmin Navigation Database contain much of the same information, pilots may notice differences in behavior, nearest list functionality, direct-to functionality, and 'Map' Page display due to data content variations.



NOTE: After performing a navigation database update, cross check with any external navigator which is providing flight plan data and verify all flight plan(s) (routes) are current. If there is an obsolete aviation point in a saved route, the route is locked and unusable. A new route with current navigation database points will need to be created.

SafeTaxi

The SafeTaxi database contains detailed airport diagrams for selected airports. These diagrams aid in following ground control instructions by accurately displaying the aircraft position on the map in relation to taxiways, ramps, runways, terminals, and services. This database is updated on a 56-day cycle.

Obstacle

The obstacle database contains data for obstacles, such as towers, that pose a potential hazard to aircraft. Obstacles 200 feet and higher are included in the obstacle database. It is very important to note that not all obstacles are necessarily charted and therefore may not be contained in the obstacle database. This database is updated on a 56-day cycle.

Terrain



NOTE: Some data contained in the terrain and obstacle databases comes from government agencies. Garmin accurately processes and cross-validates the data, but cannot guarantee the accuracy and completeness of the data.

The terrain database is updated periodically and has no expiration date.

DATABASE TROUBLESHOOTING TIPS

| Problem | Action |
|---|--|
| Unable to download databases to USB | <ul style="list-style-type: none"> - Ensure that your USB is plugged directly into your computer and not into a USB hub, computer screen, or keyboard |
| Database update fails | <ul style="list-style-type: none"> - Restart the MFI and retry the update - Download the databases again - Ensure the databases were purchased for the system ID of the MFI the database card is being used to update |
| Database SYNC fails | <ul style="list-style-type: none"> - Ensure the databases were purchased for the MFI and all interfacing equipment configured for the MFI |
| Database update fails using Garmin Pilot (Database Concierge) | <ul style="list-style-type: none"> - Ensure the account for flygarmin.com is active - Download databases for Garmin Pilot on the mobile device prior to connecting to the MFI; after the databases are up to date, connect the mobile device to the MFI while on the ground - Ensure the Database Concierge is enabled on the mobile device and on the MFI |
| Databases cannot be selected for update | <ul style="list-style-type: none"> - Restart the MFI while pressing the Small Knob until the Garmin logo is fully illuminated to view all database updates on the database card, regardless of effectivity - Download the databases again - Ensure the databases were purchased for the system ID of the GI 275 for which the database card is being used to update |

Database Troubleshooting

System Overview

Flight Instruments

EIS

Navigation

Hazard Avoidance

Autopilot

IVSI

Additional Features

Appendices

Index

Blank Page

APPENDIX C: AVIATION TERMS AND ACRONYMS

| | | | |
|------------------|---|---------------------|---|
| A | Amps, Amperes | AFTN | Aeronautical Fixed Telecommunication Network |
| ABN | Abnormal | A/G | Air-to-Ground |
| AC | Advisory Circular, Alternating Current | AGL | Above Ground Level |
| ACARS | Aircraft Communications Addressing and Reporting System | AHRS | Attitude and Heading Reference System |
| ACC | Accuracy | AIM | Aeronautical Information Manual |
| ACFT | Aircraft | AIRB | Airborne |
| ACK | Acknowledge | AIRMET, AIRM | Airman's Meteorological Information |
| ACT, ACTV | Active, Activate, Altitude Compensated Tilt | AIRREP | Air Reports |
| ADAHRS | Air Data, Attitude and Heading Reference System | ALRT | Alert, Alerting |
| ADC | Air Data Computer | ALT | Altitude |
| ADF | Automatic Direction Finder | ALT, ALTN | Alternator, Alternate |
| ADI | Attitude Direction Indicator | ALTM | Altimeter |
| ADIZ | Air Defense Identification Zone | ALTS | Altitude Select, Selected Altitude Capture Mode |
| ADM | Administrative Domain | ALTV | VNAV Altitude Capture Mode |
| ADS-B | Automatic Dependent Surveillance-Broadcast | AM | Amplitude Modulation |
| ADS-R | Automatic Dependent Surveillance-Rebroadcast | AMP | Amplifier, Ampere |
| AEA | Aircraft Electronic Association | AMPS | Amperes |
| AF | Arc to Fix Leg | ANN/ANNUNC | Annunciation/Annunciator |
| AFCS | Automatic Flight Control System | ANSP | Air Navigation Service Provider |
| AFM | Airplane Flight Manual | ANT | Antenna |
| AFMS | Airplane Flight Manual Supplement | AOA | Angle of Attack, ACARS Over AVLC |
| AFN | ATS Facilities Notification | AOC | Aeronautical Operational Control |
| AFRM | Airframe | AOG | Aircraft On Ground |
| | | AOPA | Aircraft Owners and Pilots Association |

| | | | | |
|---------------------|------------------|---|------------------|--|
| System Overview | AP | Autopilot | ATT | Attitude |
| | AP DISC | Autopilot Disconnect | AUD | Audio |
| | APPR, APR | Approach, Approach Control | AUTO | Automatic |
| Flight Instruments | APT | Airport, Aerodrome, Automatic Pitch Trim | AUTOSEQ | Automatic Sequence |
| | APTSIGNS | Airport Signs | AUX | Auxiliary |
| | APU | Auxiliary Power Unit | AVAIL | Available |
| EIS | APV | Approaches with Vertical Guidance | AVG | Average |
| | ARINC | Aeronautical Radio Incorporated | AVLC | Aviation VHF Link Control |
| Navigation | ARM | Arm, Armed | AWOS | Automated Weather Observing System |
| | ARSPC | Airspace | AZ | Azimuth |
| | ARTCC | Air Route Traffic Control Center | B | Both Runways |
| Hazard Avoidance | ARV | Arrival | B ALT | Barometric Altitude |
| | AS | Airspeed | BC, B/C | Back Course |
| | ASB | Aviation Support Branch | BARO | Barometer, Barometric Setting |
| Autopilot | ASI | Airspeed Indicator | BATT | Battery |
| | ASOS | Automated Surface Observing System | Bearing | The compass direction from the present position to a destination waypoint. |
| | AT | Auto Throttle | BFO | Beat Frequency Oscillator |
| WSI | ATAS | ADS-B Traffic Advisory System | BKLT | Backlight |
| | ATC | Air Traffic Control | BKSP | Backspace |
| | ATCRBS | ATC Radar Beacon System | BLKHD | Bulkhead |
| Additional Features | ATD | Along-Track Distance | Bluetooth | Wireless standard for data exchange over short distances |
| | ATE | Along-Track Error, Automatic Test Equipment | BOC | Bottom of Climb |
| | ATIS | Automatic Terminal Information Service | BOD | Bottom of Descent |
| Appendices | ATK | Along Track | BRG | see also Bearing |
| | ATN | Aeronautical Telecommunications Network | BRK | Brake |
| | ATS | Air Traffic Services | BTM | Bottom |

| | | | |
|----------------------------|--|------------------------|--|
| °C | Degrees Celsius | CM | Centimeter |
| C | Center Runway | CMC | Central Maintenance Computer |
| CA | Course to Altitude Leg | CMPRTC | Comparator |
| CAL | Calibrated | CN | Canada |
| CALC | Calculator | CNCL | Cancel |
| Calibrated Airspeed | Indicated airspeed corrected for installation and instrument errors. | CNFM | Confirm |
| CAS | Crew Alerting System | CNI | Communication, Navigation, & Identification |
| CLB | Climb | CNS | Communication, Navigation, & Surveillance |
| CB | Circuit Breaker | CO | Carbon Monoxide |
| CCG | Current Climb Gradient | COM | Communication Radio |
| CD | Course to DME Distance Leg | COMP | Compensated, Compensation |
| CDA | Current Data Authority | CONFIG | Configuration |
| CDI | Course Deviation Indicator | CONUS | Continental United States |
| CDU | Control Display Unit | COOL | Coolant |
| CF | Course to Fix Leg | COPLT | Copilot |
| CFG | Configuration | CORR | Correct, Corrected, Correction |
| CFIT | Controlled Flight into Terrain | Course | The line between two points to be followed by the aircraft. |
| CG | Center of Gravity | Course to Steer | The recommended direction to steer in order to reduce course error or stay on course. Provides the most efficient heading to get back to the desired course and proceed along the flight plan. |
| CH, CHNL | Channel | | |
| CHKLIST | Checklist | | |
| CHRG | Charge | | |
| CHT | Cylinder Head Temperature | | |
| CI | Course to Intercept Leg | | |
| CIP | Current Icing Potential | | |
| CL | Class, Centerline | CP | Copilot, Control Panel |
| CLB | Climb | CPDLC | Controller Pilot Datalink Communications |
| CLD | Cloud | | |
| CLG | Ceiling | CPL | Couple |
| CLR | Clear | CR | Course to Radial Leg |
| CLS | Close | CRG | Cockpit Reference Guide |
| CLTR | Clutter | CRNT | Current |

| | | | | |
|---------------------|-------------------------|---|------------------------------|---|
| System Overview | Crosstrack Error | The distance the aircraft is off a desired course in either direction, left or right. | dBZ | Decibels 'Z' (Radar Return) |
| | CRS | see also Course, Course to Steer | DCL | Departure Clearance |
| Flight Instruments | CRSR | Cursor | DCLTR, DECLTR | Declutter |
| | CRU, CRZ | Cruise | DEC | Declination |
| | CSA | Conflict Situational Awareness | DEC FUEL | Decrease Fuel |
| EIS | CSC | Current Speed Control | DEG | Degree |
| | CSTR | Constraint | DEIC, DEICE | De-icing |
| | CTA | Control Area | DEL | Delete |
| Navigation | CTAF | Common Traffic Advisory Frequency | DEP | Departure, Departure Control |
| | CTR | Center | DESC | Descent |
| | CTRL | Control | Desired Track | The desired course between the active "from" and "to" waypoints. |
| Hazard Avoidance | Cumulative, CUM | The total of all legs in a flight plan. | DEST, DES | Destination, Destination Airport Identifier |
| | CVDR | Cockpit Voice Data Recorder | DET | Detect, Detected, Detection, Detector |
| Autopilot | CVFP | Charted Visual Flight Procedure | DEV | Deviation |
| | CVR | Cockpit Voice Recorder | DF | Direction Finder, Direct to Fix Leg |
| | CVRG | Coverage | DFLT | Default |
| WSI | CWS | Control Wheel Steering | DG | Directional Gyro |
| | CYC CTR | Cyclic Centering | DGPS | Differential GPS |
| | CYL | Cylinder | DGRD | Degrade |
| Additional Features | CZ | Control Zone | DH | Decision Height |
| | D->, D→ | Direct-To | DIFF | Differential |
| | D/A | Digital to Analog Converter | Dilution of Precision | A measure of GPS satellite geometry quality on a scale of one to ten (lower numbers equal better geometry, where higher numbers equal poorer geometry). |
| Appendices | D ALT | Density Altitude | DIR | Direction |
| | D-ATIS | Digital Automatic Terminal Info Service | DIS | Distance |
| | DA | Decision Altitude, Drift Angle | DISENG | Disengage |
| Index | DB, DBASE | Database | | |

| | | | |
|-----------------|--|------------------------------------|--|
| Distance | The 'great circle' distance from the present position to a destination waypoint. | ECS | Environmental Control System |
| DIV | Divert, Diversion | ECU | Engine Control Unit |
| DL LTNG | Datalink Lightning | EDM | Emergency Descent Mode |
| DLS | Data Link System | EDR | Excessive Descent Rate |
| DME | Distance Measuring Equipment | EFC | Expected Further Clearance |
| DN | Down | Efficiency | A measure of fuel consumption, expressed in distance per unit of fuel. |
| DNALT | Density Altitude | EGNOS | European Geostationary Navigation Overlay Service |
| DNGR | Danger | EGT | Exhaust Gas Temperature |
| DNLK | Downlink | EICAS | Engine Indication and Crew Alerting System |
| DOD | Department of Defense | EIS | Engine Indication System |
| DOP | see also Dilution of Precision | ELEC | Electrical |
| DOPP | Doppler | ELEV | Elevation, Elevator |
| DP | Departure Procedure, Differential Pressure | ELT | Emergency Locator Transmitter |
| DPRT | Departure | EMER, EMERG, EMERGCY | Emergency |
| DQR | Data Quality Requirements | EMI | Electromagnetic Interference |
| DR | Dead Reckoning | END, ENDUR | Endurance |
| DSBL | Disabled | Endurance | Flight endurance, or total possible flight time based on available fuel on board. |
| DSP | Display, Datalink Service Provider, Digital Signal Processor | ENG | Engine |
| DTG | Distance To Go, Remaining distance to last active FPL waypoint | ENGA | Engage |
| DTK | see also Desired Track | ENGD | Engaged |
| DWNGRADE | Downgrade | ENR | Enroute; ETE to Final Destination |
| E | Empty, East | Enroute Safe Altitude (ESA) | Uses Grid MORAs to determine a safe altitude within ten miles left or right of the desired course on an active flight plan or direct-to. |
| EAS | Engine and Airframe Systems | | |
| EC | Error Correction | | |
| ECC | Error Correcting Code | | |
| ECL | Electronic Checklist | | |
| ECR | Excessive Closure Rate | | |

| | | | | |
|---------------------|--|--|------------------|--|
| System Overview | ENT | Enter | EXTING | Extinguish, Extinguisher |
| | EP | Envelope Protection | EXTR | Extract, Extraction |
| | EPE | see also Estimated Position Error | °F | Degrees Fahrenheit |
| Flight Instruments | EPU | Estimated Position Uncertainty | FA | Course From Fix to Altitude Leg |
| | ERR | Error | FAA | Federal Aviation Administration |
| | ES | Extended Squitter | FADEC | Full Authority Digital Engine Control |
| EIS | ESA | Emergency Safe Altitude, see also Enroute Safe Altitude | FAF | Final Approach Fix |
| | ESP | Electronic Stability and Protection | FAIL | Failure |
| Navigation | Estimated Position Error (EPE) | A measure of horizontal GPS position error derived by satellite geometry conditions and other factors. | FANS | Future Air Navigation System |
| | Estimated Time Enroute (ETE) | The estimated time it takes to reach the destination waypoint from the present position, based upon current groundspeed. | FAP | Final Approach Point |
| Hazard Avoidance | Estimated Time of Arrival (ETA) | The estimated time at which the aircraft should reach the destination waypoint, based upon current speed and track. | FAPP | Final Approach |
| | ET | Elapsed Time | FAR | Federal Aviation Regulations |
| Autopilot | ETA | see also Estimated Time of Arrival | FBO | Fixed Base Operator |
| | ETE | see also Estimated Time Enroute | F/C | Flight Crew |
| WSI | EVS | Enhanced Vision System | FC | Course From Fix to Distance Leg |
| | EXP | Expand | FCC | Federal Communication Commission |
| Additional Features | EXPIRD | Expired | FCST | Forecast |
| | EXT | External | FCTN | Function |
| Appendices | EXTD | Extend | FD | Flight Director, Course From Fix to DME Distance Leg |
| | | | FDE | Fault Detection and Exclusion |
| Index | | | FDR | Flight Data Recorder |
| | | | FF, FFLOW | see also Fuel Flow |
| | | | FIS-B | Flight Information Services-Broadcast |
| | | | FISDL | Flight Information Service Data Link |
| | | | FIT | Flight Into Terrain |
| | | | FL | Flight Level |

| | | | |
|------------------------------|--|----------------|---|
| FLC, FLCH | Flight Level Change | GA | Go-Around |
| FLT | Flight, Flight Timer | GAGAN | GPS Aided GEO Augmented Navigation |
| FLTA | Forward Looking Terrain Avoidance | GAGL | GPS AGL Altitude |
| FLW | Follow, Following | GAL, GL | Gallon(s) |
| FM | Course From Fix to Manual Termination Leg | GBAS | Ground Based Augmentation System |
| FMS | Flight Management System | GBOX | Gearbox |
| FOB | see also Fuel On Board | GBT | Ground Based Transceiver |
| FOD | see also Fuel Over Destination | GCS | Ground Clutter Suppression |
| FPA | Flight Path Angle | GCSS | Garmin Connex Satellite Services |
| FPL | Flight Plan | GCU | Garmin Control Unit |
| FPM | Feet Per Minute, Flight Path Marker | GDC | Garmin Air Data Computer |
| FR | From | GDL | Garmin Satellite Data Link |
| FREQ | Frequency | GDR | Garmin Data Radio |
| FRMT | Format | GDU | Garmin Display Unit |
| FRT | Front | GEA | Garmin Engine/Airframe Unit |
| FRZ | Freezing | GEAR | Landing Gear |
| FSD | Full-Scale Deflection | GEN | Generator |
| FSM | Flight System Messages | GEO | Geographic |
| FSS | Flight Service Station | GFC | Garmin Flight Control |
| FT | Foot/Feet | GHz | Gigahertz |
| Fuel Flow | The fuel flow rate, expressed in units of fuel per hour. | GIA | Garmin Integrated Avionics Unit |
| Fuel On Board | The total amount of usable fuel on board the aircraft. | GLONASS | Global Orbiting Navigation Satellite Landing System |
| Fuel Over Destination | The estimated fuel remaining when the aircraft reaches the destination waypoint, based upon current fuel flow. | GLS | Global Navigation Satellite Landing System |
| FWD | Forward | GMA | Garmin Audio Panel System |
| G/A | Ground to Air | GMC | Garmin Mode Controller |
| G/S | Glideslope | GMT | Greenwich Mean Time |
| | | GMU | Garmin Magnetometer Unit |
| | | GND | Ground |

| | | | | |
|---------------------|---|---|-----------------------------------|--|
| System Overview | GOLD | Global Operational Data Link | GW | Gross Weight |
| | GP | Glidepath | GWX | Garmin Weather Radar |
| | GPH | Gallons per Hour | H | Hours |
| Flight Instruments | GPN | Garmin Part Number | H+MM | Hours and Minutes |
| | GPS | Global Positioning System | HA | Hold Terminating at Altitude Leg |
| | GPWS | Ground Proximity Warning System | HAL | Horizontal Alert Limit |
| EIS | Grid MORA (Minimum Off-Route Altitude) | One degree latitude by one degree longitude in size and clears the highest elevation reference point in the grid by: a) 1,000 feet where the highest elevation is <5001MSL or b) 2,000 feet where the highest elevation is >5000MSL | HAT | Height Above Threshold |
| | | | HDG | see also Heading |
| Navigation | | | HDOP | Horizontal Dilution of Precision |
| | | | Heading | The direction an aircraft is pointed, based upon indications from a magnetic compass or a properly set directional gyro. |
| Hazard Avoidance | Ground Track | See Track | HF | High Frequency, Hold Terminating at Fix Leg |
| | Groundspeed | The velocity the aircraft is travelling relative to a ground position. | HFOM | see also Horizontal Figure of Merit |
| Autopilot | GRP | Geographic/Ground Reference Point | Hg | Mercury |
| | GRS | Garmin Reference System | HI | High |
| WSI | GS | Ground Speed, Glideslope | HI SENS | High Sensitivity |
| | GSA | Garmin Servo Adapter | HLD | Hold, Holding, Holding Pattern |
| Additional Features | GSD | Glideslope/Glidepath Deviation, Garmin Data Concentrator | HM | Hold with Manual Termination Leg |
| | GSL | Geometric/Geodetic Sea Level | HNS | Hybrid Navigation Sensor |
| Appendices | GSR | Garmin Satellite Radio | Horizontal Figure of Merit | A measure of the uncertainty in the aircraft's horizontal position. |
| | GSU | Garmin Sensor Unit | HOV | Hover |
| | GTC | Garmin Touchscreen Controller | HOV-P | Hover Prediction |
| Index | GTS | Garmin Traffic System | HP | High Pressure, Horsepower |
| | GTX | Garmin Transponder | hPa | Hectopascal |

| | | | |
|--------------------|---|----------------------|--|
| HPI | Hover Power Indicator | IG | Imperial Gallon |
| HPL | Horizontal Protection Level | IGE | In Ground Effect |
| HR | Hour | ILI | Imminent Line Impact |
| HRZN HDG | Horizon Heading | ILS | Instrument Landing System |
| HSDB | High-Speed Data Bus | IM | Inner Marker |
| HSI | Horizontal Situation Indicator | IMC | Instrument Meteorological Conditions |
| HT | Heat, Height | IN | Inch |
| HTR | Heater | IN Hg, "HG | Inches of Mercury |
| HUL | Horizontal Uncertainty Level | INACTV | Inactive |
| HWND | Headwind | INBD | Inboard |
| HYD | Hydraulic | INBND | Inbound |
| Hz | Hertz (cycles per second) | INC FUEL | Increase Fuel |
| HZN | Horizon | IND | Indicator, Indicated |
| I | Inner Marker | Indicated | Information provided by properly calibrated and set instrumentation on the aircraft panel. |
| IAF | Initial Approach Fix | INDX | Index |
| IAP | Instrument Approach Procedure | INFO | Information |
| IAS | Indicated Air Speed | INH, INHIB | Inhibit |
| IAT | Indicated Air Temperature | INOP | Inoperative |
| IATA | International Air Transport Association | INS | Inertial Navigation System |
| IAU | Integrated Avionics Unit | INSTR | Instrument |
| IBD, INBD | Inboard | INT | Intersection(s) |
| ICAO | International Civil Aviation Organization | INTEG | Integrity (RAIM unavailable) |
| ICE | Icing | INTERN, INTRL | Internal |
| ICS | Intercom System | INV | Invalid |
| ID | Identification/Morse Code Identifier | IOI | Imminent Obstacle Impact |
| IDENT, IDNT | Identification | IR | Infrared |
| IEEE | Institute of Electrical & Electronics Engineers | IrDA, IRDA | Infrared Data Association |
| IF | Initial Fix | IRST | Infrared Surveillance and Tracking |
| IFR | Instrument Flight Rules | | |

| | | | | |
|---------------------|--------------------------------|---|--------------------|--|
| System Overview | ISA | International Standard Atmosphere; ISA Relative Temperature | Leg | The portion of a flight plan between two waypoints. |
| Flight Instruments | ISO | International Standards Organization | LEN | Length |
| EIS | ISOL | Isolation | LGND | Legend |
| Navigation | ITI | Imminent Terrain Impact | LIFR | Low Instrument Flight Rules |
| Hazard Avoidance | ITT | Inter-Turbine Temperature, Interstage Turbine Temperature | LI-ION | Lithium Ion |
| Autopilot | KEYSTK | Key Stuck | LIM | Limit |
| WSI | KG | Kilogram | LMM | Location Middle Marker |
| Additional Features | KHz | Kilohertz | LNAV | Lateral Navigation |
| Appendices | KM | Kilometer | LO | Low |
| Index | KT | Knot | LOA | Letter of Authorization |
| | L | Left, Left Runway | LOC | Localizer |
| | LAT | Latitude, Lateral | LOI | Loss of Integrity (GPS) |
| | LB | Pound | LOM | Location Outer Marker |
| | LBL | Label | LON, LONG | Longitude, Longitudinal |
| | LCD | Liquid Crystal Display | LP | Localizer Performance, Low Pressure |
| | LCL | Local | LPV | Localizer Performance with Vertical Guidance |
| | LDA | Landing Distance Available | LRU | Line Replaceable Unit |
| | LDG | ETA at Final Destination | LSB V | Lower Sideband Voice |
| | LED | Light Emitting Diode | LT | Left, Light |
| | Left Over Fuel On Board | The amount of fuel remaining on board after the completion of one or more legs of a flight plan or direct-to. | LTNG | Lightning |
| | Left Over Fuel Reserve | The amount of flight time remaining, based on the amount of fuel on board after the completion of one or more legs of a flight plan or direct-to, and a known consumption rate. | LVL | Level |
| | | | M | Meter, Middle Marker, Mach |
| | | | Mach Number | Mach number is the ratio of the true airspeed to the speed of sound. |
| | | | MAG | Magnetic |
| | | | MAG VAR | Magnetic Variation |
| | | | MAHP | Missed Approach Hold Point |
| | | | MAINT | Maintain |
| | | | MAL | Malfunction |
| | | | MAN | Manual |

| | | | |
|---------------|--|------------------------------------|---|
| MAN IN | Manifold Pressure (inches Hg) | Minimum Safe Altitude (MSA) | Uses Grid MORAs to determine a safe altitude within ten miles of the aircraft present position. |
| MAN SQ | Manual Squelch | | |
| MANSEQ | Manual Sequence | | |
| MAP | Missed Approach Point | MKR | Marker Beacon |
| MAPROC | Missed Approach Procedure | MM | Middle Marker |
| MASQ | Master Avionics Squelch | MMO (VMO) | Maximum Speed |
| MAX | Maximum | MOA | Military Operations Area |
| MAXSPD | Maximum Speed (overspeed) | MOD | Modification, Modify |
| MB | Marker Beacon, Millibar(s) | MON | Monitor, Monitored, Monitoring |
| MCDU | Multifunction Control and Display Unit | MORA | Minimum Off-Route Altitude |
| | | MOV | Movement |
| MCLB | Maximum Climb Thrust | MPEL | Maximum Permissible Exposure Level |
| MCP | Maximum Continuous Power | | |
| MCRZ | Maximum Cruise Thrust | MPM | Meters per Minute |
| MDA | Barometric Minimum Descent Altitude | MSA | see also Minimum Safe Altitude |
| MEA | Minimum Enroute Altitude | MSAS | Multi-functional Satellite Augmentation System |
| MEM | Memory | | |
| MEPT | Manual Electric Pitch Trim | MSG | Message |
| MET | Manual Electric Trim | MSL | Mean Sea Level |
| METAR | Aviation Routine Weather Report | MT, M | Meter |
| | | MTG | Mounting |
| METRO | Metropolitan | MTN | Mountain |
| MFD | Multi Function Display | MTOGW | Maximum Takeoff Gross Weight |
| MGRS | Military Grid Reference System | | |
| | | MTOW | Maximum Takeoff Weight |
| MGT | Measured Gas Temperature | mV | Millivolt(s) |
| MHz | Megahertz | MVFR | Marginal Visual Flight Rules |
| MIC | Microphone | N | North |
| MID | Middle | NATS | North Atlantic Tracks System |
| MIN | Minimum, Minute | NAV | Navigation |
| | | NAVAID | Navigation Aid |

| | | | | |
|---------------------|-------------------|--|------------------|---|
| System Overview | NCR | Negative Climb Rate | OOOI | Out of the gate, Off the ground, On the ground, and In the gate |
| | NDA | Next Data Authority | | |
| | NDB | Non-Directional Beacon | | |
| | NEG | Negative | OROCA | Off Route Obstacle Clearance Altitude |
| Flight Instruments | NEXRAD | Next Generation Radar | OUTBD | Outboard |
| | NG | Gas Producer Rotation Speed | OUTBND | Outbound |
| | NM | Nautical Mile(s) | OVBD | Overboard |
| EIS | NMPG | Nautical Miles per Gallon | OVFL | Overflow |
| | NoPT | No Procedure Turn Required (procedure shall not be executed without ATC clearance) | OVFLY | Overfly, Overflying |
| | | | OVHD | Overhead |
| Navigation | NORM | Normal | OVHT | Overheat |
| | NOTAM | Notice To Airman | OVLIM | Overlimit |
| | NP | Power Turbine Speed | OVLN | Overload |
| Hazard Avoidance | NPA | Non-Precision Approach | OVPR | Overpressure |
| | NR | Rotor Speed | OVR, OVRD | Override |
| | NRST | Nearest | OVRN | Overrun |
| Autopilot | NWHL | Nosewheel | OVSPD | Overspeed |
| | NWS | National Weather Service, Nosewheel Steering | OVTMP | Overtemperature |
| | O | Outer Marker | OXY | Oxygen |
| WSI | OAT | Outside Air Temperature | P ALT | Pressure Altitude |
| | OBD, OUTBD | Outboard | P-ATT | Pitch Attitude |
| | OBS | Omni Bearing Selector, Observation, Observe, Observed | PA | Precision Approach, Passenger Address, Proximity Advisory |
| Additional Features | OBSCR | Obscuration | PB | Push Button |
| | OCL | Oceanic Clearance | PASS, PAX | Passenger(s) |
| Appendices | OEM | Original Equipment Manufacturer | PC | Personal Computer |
| | OFST | Offset | PDA | Premature Descent Alerting |
| | OGE | Out of Ground Effect | PDC | Pre-Departure Clearance |
| Index | OM | Outer Marker | PED | Personal Electronic Device |
| | | | PERF | Performance |
| | | | PFD | Primary Flight Display |

| | | | |
|-----------------------|---|----------------|---|
| PG | Pilot's Guide | Q | Engine Torque |
| PI | Procedure Turn to Course Intercept Leg | QFE | Field Elevation Pressure |
| PIREP | Pilot Report | QNE | Pressure Altitude |
| PIT, PTCH | Pitch | QNH | Sea Level Pressure |
| PLT | Pilot | QTY | Quantity |
| PNR | Prior Notice Required | R | Right, Right Runway |
| POA | Plain Old ACARS | RA | Resolution Advisory, Radio Altimeter, Radar Altimeter |
| POB | Persons (Souls) on Board | RAD | Radial |
| POF | Phase of Flight | RAD ALT | Radio Altimeter, Radar Altimeter |
| POH | Pilot's Operating Handbook | RAIM | Receiver Autonomous Integrity Monitoring |
| POHS | Pilot's Operating Handbook Supplement | RAM | Random Access Memory |
| POS, POSN | Position | RAT | Ram Air Temperature |
| POSS | Possible | RCVR | Receiver |
| PPH | Pounds per Hour | R/D | Radial/Distance |
| PPM | Parts per Million | RDR | Radar |
| PPOS, P. POS | Present Position | REC | Record, Recorder |
| PREFLT | Preflight | RECIRC | Recirculate/Recirculating |
| PRES, PRESS, P | Pressure | REF | Reference |
| PREV | Previous | REGL | Regulator |
| PRI | Primary | REM | Remaining (fuel remaining), Reminder, Removed, Remote |
| PRL | Parallel | REQ | Request |
| PRN | Pseudo Random Noise | REQD | Required |
| PROC | Procedure(s), Procedure Turn | RES | Reserve (fuel reserve entered by pilot) |
| PROP | Propeller | REST | Restricted, Restriction |
| PROX | Proximity | RET | Return |
| PSI | Pounds per Square Inch, Power Situation Indicator | REV | Reverse, Revision, Revise |
| PT | Procedure Turn | RF | Radio Frequency, Constant Radius Turn to Fix Leg |
| PTK | Parallel Track | RFM | Rotorcraft Flight Manual |
| PTT | Push-to-Talk | | |
| PWR | Power | | |

| | | | | |
|---------------------|------------------|--|------------------|--|
| System Overview | RLC | Required Line Clearance | S | South |
| | RMI | Radio Magnetic Indicator | SA | Selective Availability |
| | RMT | Remote | SAIB | Special Airworthiness Information Bulletin |
| Flight Instruments | RNAV | Area Navigation | | |
| | RNG | Range | SAR | Search and Rescue |
| | RNP | Required Navigation Performance | SAT | Static Air Temperature |
| | | | SATCOM | Satellite Communication |
| EIS | RNWW, RWY | Runway | SBAS | Satellite-Based Augmentation System |
| | ROASS | Runway Overrun Awareness and Alerting System | S-CLB | Step Climb |
| Navigation | ROC | Required Obstacle Clearance, Rate of Climb | SC | Short Circuit |
| | ROD | Rate of Descent | SCIT | Storm Cell Identification and Tracking |
| | ROL | Roll | S-DES | Step Descent |
| Hazard Avoidance | ROM | Read Only Memory | SD | Secure Digital |
| | ROT | Rotary | SEC | Second(s) |
| | RPM | Revolutions Per Minute | SECT | Section |
| Autopilot | RQRD | Required | SEG | Segment |
| | RST FUEL | Reset Fuel | SEL, SLCT | Select |
| | RSV | Reserve (fuel reserve entered by pilot) | SELCAL | Selective Calling |
| WSI | RT | Right | SENS | Sense, Sensitivity |
| | RTC | Required Terrain Clearance | SEQ | Sequence, Sequencing |
| | RTE | Route | SERV | Service, Servicing, Served |
| Additional Features | RTR | Router | SET | Setup |
| | RUDICS | Router-Based Unrestricted Digital Interworking Connectivity Solution | SFC | Surface |
| Appendices | | | SHT | Short |
| | RVRSNRY | Reversionary | SIAP | Standard Instrument Approach Procedures |
| | RVSI | Required Vertical Speed Indicator | SID | Standard Instrument Departure |
| Index | RVSM | Reduced Vertical Separation Minimums | SIG | Signal |
| | | | SIG/AIR | SIGMET/AIRMET |
| | RX | Receive | SIGM | SIGMET |

| | | | |
|------------------|--|-------------------|--|
| SIGMET | Significant Meteorological Information | STN | Station |
| SIM | Simulator | STR | Strip |
| SITA | Societe Internationale de Telecommunications | STRMSCP | Stormscope |
| SLD | Supercooled Large Droplet | SUA | Special Use Airspace |
| SLP/SKD | Slip/Skid | SUB | Substitute |
| SLW | Slow | SUPPRESS | Suppression |
| SM | Statute Mile | SURF | Surface |
| SMBL | Symbol | SUSP | Suspend |
| SMK | Smoke | SVBL | Serviceable |
| SMS | Short Message System | SVT | Synthetic Vision Technology |
| SNGL | Single | SW | Software |
| SOB | Souls on Board | SYN TERR | Synthetic Terrain |
| SPBK | Speed Brake | SYN VIS | Synthetic Vision |
| SPC | Space | SYNC | Synchronize |
| SPD | Speed | SYNTH | Synthesizer |
| SPI | Special Position Identification | SYS | System |
| SPKR | Speaker | T | True |
| SQ, SQL | Squelch | T HDG | True Heading |
| SRVC, SVC | Service | T/R | Thrust Reverser |
| SSEC | Static Source Error Correction | TA | Traffic Advisory, Transition Altitude |
| SSID | Wireless Service Set Identifier | TAC | Tactical |
| STAB | Stabilization | TACAN, TCN | Tactical Air Navigation System |
| STAL | Stall | TAF | Terminal Aerodrome Forecast |
| STAR | Standard Terminal Arrival Route | TAS | True Airspeed, Traffic Advisory System |
| STAT | Status | TAT | Total Air Temperature |
| STATS | Statistics | TAWS | Terrain Awareness and Warning System |
| STBY | Standby | TCA | Terminal Control Area |
| STC | Sensitivity Time Constant, Supplemental Type Certificate | TCAS | Traffic Alert Collision Avoidance System |
| STD | Standard | TCH | Threshold Crossing Height |

| | | | | |
|---------------------|--------------------|--|--------------------------|--|
| System Overview | TD | Touchdown | Track | Direction of aircraft movement relative to a ground position; also 'Ground Track'. |
| | TEL | Telephone | | |
| | TEMP | Temperature | | |
| | TERM | Terminal | Track Angle Error | The angle difference between the desired track and the current track. |
| Flight Instruments | TERR | Terrain | | |
| | T/F | To/From | | |
| | TF | Track Between Two Fixes Leg | TRFC | Traffic |
| | TFR | Temporary Flight Restriction | TRK | see also Track |
| EIS | TGT | Target | TRN | Terrain |
| | TH | True Heading | TRSA | Terminal Radar Service Area |
| Navigation | THLD | Threshold | TRUNC | Truncated |
| | THR | Thrust | TSO | Technical Standard Order |
| | TIS | Traffic Information Service | TST | Test |
| | TIS-B | Traffic Information Service-Broadcast | TTA | Time-to-Alert |
| Hazard Avoidance | TIT | Turbine Inlet Temperature | TTK | True Track |
| | TKE | see also Track Angle Error | TTL | Total |
| | TL | Transition Level | TTS | Text to Speech |
| Autopilot | TLA | Throttle Lever Angle, Thrust Lever Angle | TUR | Turbine |
| | TMA | Terminal Maneuvering Area | TURB | Turbulence |
| | TMR/REF | Timer/Reference | TURN | Procedure Turn |
| WSI | TNK | Tank | TWND | Tailwind |
| | TO | To, Takeoff | TWIP | Terminal Weather Information for Pilots |
| | TOC | Top of Climb | TWR | Tower |
| Additional Features | TOD | Top of Descent, Time to TOD | TWY | Taxiway |
| | TOGA, TO/GA | Take-Off, Go-Around | TX | Transmit |
| | TOLD | Takeoff and Landing Data | UA | Routine PIREP |
| Appendices | TOPO | Topographic | UAT | Universal Access Transceiver |
| | TORA | Takeoff Run Available | UHF | Ultra-High Frequency |
| | TOT | Total | UNABL | Unable |
| Index | TPA | Traffic Pattern Altitude | UNAVAIL | Unavailable |
| | | | UNLIM | Unlimited |
| | | | UPLK | Uplink |

| | | | |
|--|---|--|---|
| US | United States | Vertical Speed Required | The vertical speed necessary to descend/climb from a current position and altitude to a defined target position and altitude, based upon current groundspeed. |
| USB V | Upper Sideband Voice | | |
| USR | User | | |
| UTC | Coordinated Universal Time | | |
| UTM/UPS | Universal Transverse Mercator/ Universal Polar Stereographic Grid | V_{FE} | Maximum Flap Extended Speed |
| UUA | Urgent PIREP | VFOM | see also Vertical Figure of Merit |
| V | Volts, Vertical | VFR | Visual Flight Rules |
| V DEV | Vertical Deviation | VHF | Very High Frequency |
| V, Vspeed | Velocity (airspeed) | VI | Heading Vector to Intercept Leg |
| V₁ | Takeoff Decision Speed | VIB | Vibration |
| V₂ | Takeoff Safety Speed | V_{LE} | Maximum Landing Gear Extended Speed |
| V_A | Maneuvering Speed | V_{LNDx} | Approach Speed (Flaps at x°) |
| VA | Heading Vector to Altitude Leg | V_{LO} | Maximum Landing Gear Operating Speed |
| VAC | Volts Alternating Current | VLD | Valid |
| VAL | Vertical Alert Limit | VLOC, VOR/L | VOR/Localizer Receiver |
| VAPP | VOR Approach Mode | VM | Heading Vector to Manual Termination Leg |
| V_{APP}, V_{AC} | Approach Climb Speed | V_{MC} | Minimum Control Speed |
| VAR | Variable, Variation | VMC | Visual Meteorological Conditions |
| VCO | Voice Call Out | V_{MO} (M_{MO}) | Maximum Operating Speed |
| VD | Heading Vector to DME Distance Leg | VNAV, VNV | Vertical Navigation |
| VDC | Volts Direct Current | V_{NE} | Never-Exceed Speed |
| VDI | Vertical Deviation Indicator | VOL | Volume |
| VDL | VHF Datalink | VOR | VHF Omnidirectional Range |
| VECT | Vector | VOR/D | VOR/DME |
| VERT | Vertical | VOR/I | VOR/ILS |
| Vertical Figure of Merit | A measure of the uncertainty in the aircraft's vertical position. | | |

| | | | | |
|---------------------|-------------------------|---|------------------------|--|
| System Overview | VORTAC | VHF Omnidirectional Range Station and Tactical Air Navigation | WSPD | Wind Speed |
| | | | WGS-84 | World Geodetic System - 1984 |
| | VPATH, VPTH | Vertical Path | WI-FI, WIFI | Wireless Local Area Network based on IEEE 802.11 |
| Flight Instruments | VPL | Vertical Protection Level | WILCO | Will Comply |
| | VPROF | VNAV Profile, Vertical Profile | WINDSHR, WSHEAR | Windshear |
| | V_R | Takeoff Rotate Speed | WL | Wings Level |
| EIS | VR | Heading Vector to Radial Leg | WOG | Weight on Gear |
| | V_{REF} | Landing Approach Speed, Reference Landing Speed | WOW | Weight on Wheels |
| | VRP | Visual Reporting Point | WPT | Waypoint(s) |
| Navigation | VS | Vertical Speed | WT | Weight |
| | V_{SB} | Maximum Speedbrake Speed | W/V | Wind Velocity |
| | VSD | Vertical Situation Display | WW | World Wide |
| Hazard Avoidance | VSI | Vertical Speed Indicator | WX | Weather |
| | V_{SR} | Stall Speed | WXR | Weather Radar |
| | VSR, VS REQ | see also Vertical Speed Required | XFD | Crossfeed |
| Autopilot | V_T | Takeoff Flap Retraction Speed | XFER, XFR | Transfer |
| | VTE | Vertical Track Error | XFLOW | Crossflow |
| | VTF | Vector to Final | XM LTNG | SiriusXM Lightning |
| WSI | VTK | Vertical Track | XMIT | Transmit |
| | V_{TIRE} | Maximum Tire Speed | XMSN | Transmission |
| | V_X | Best Angle of Climb Speed | XPDR | Transponder |
| Additional Features | V_Y | Best Rate of Climb Speed | XTALK | Cross-Talk |
| | V_{YSE} | Best Single-Engine Rate of Climb Speed | XTE | Crosstrack Error |
| Appendices | W | Watt(s), West | XTK | Cross-Track, Crosstrack Error |
| | WAAS | Wide Area Augmentation System | YD | Yaw Damper |
| | WARN | Warning | Z | Reflectivity Factor |
| Index | WATCH | Weather Attenuated Color Highlight | | |
| | WDIR | Wind Direction | | |

APPENDIX D: DISPLAY SYMBOLS





VFR SYMBOLS

| Item | Symbol |
|----------------------------|--------|
| Unknown | |
| Non-towered, Non-serviced | |
| Towered, Non-serviced | |
| Non-towered, Serviced | |
| Towered, Serviced | |
| Soft Surface, Non-serviced | |
| Soft Surface, Serviced | |
| Soft Surface, Private | |
| Paved, Private | |
| Heliport | |

Airports

IFR SYMBOLS

| Item | Symbol |
|---------------------------------------|---|
| Intersection |  |
| Visual Reporting Point |  |
| LOM (Compass Locator at Outer Marker) |  |
| NDB (Non-Directional Radio Beacon) |  |
| VOR |  |
| VOR/DME |  |
| ILS/DME or DME Only |  |
| VORTAC |  |
| TACAN |  |

| Item | Symbol |
|--------------------|---|
| Interstate Highway |  |
| US Highway |  |
| State Highway |  |
| National Highway |  |
| Small City |  |
| Medium City |  |
| Large City |  |

Miscellaneous

Navaids

| Item | Symbol |
|---------------|---|
| Low-Altitude |  |
| High-Altitude |  |

Airways

AIRSPACE SYMBOLS

| Item | Symbol |
|---|--------|
| Class B, Class E, CTA | |
| Class A, Class C, TMA | |
| Class D | |
| Mode C Veil | |
| TRSA | |
| MOA | |
| Danger, Alert, or Training Area | |
| Restricted, Prohibited, or Warning Area | |
| Radar Area | |
| ATZ, TIZ | |
| MATZ | |
| ADIZ | |
| Misc./Unknown | |

Airspace

System Overview

Flight Instruments

EIS

Navigation

Hazard Avoidance

Autopilot

IVSI

Additional Features

Appendices

Index

Blank Page

Index

A

Acronyms 289
 ADS-B 190 191 192 194 195
 Advisory 94 95 273
 AFCS Controller 199
 AIRMET 165
 Airport Signs 257
 Alert Level Definitions 273
 Annunciations and Alerts 274
 Autopilot
 Disengage 203

B

Basemap 286

C

Caution 94 95 273
 Cell Movement 156
 City Forecast 159 165
 Cloud Tops 156
 Command Bars 200
 County Warnings 158 165
 Current Icing Product (CIP) 158
 Cyclone 159

D

Databases 286
 Database Troubleshooting 287
 Decision Height, Radar Altimeter 245
 246
 Direct To 132
 Discrete Configurations 203

E

EAS 293
 EICAS 293
 EIS 293
 Engine Indication System (EIS)
 Gauge and Indicator Types 69

Excessive Descent Rate (EDR) 175

F

FIS-B Weather 154
 Flight Director 199
 Flight Path Marker 256
 Flight Plan
 Leg Type 136
 Forward Looking Terrain Avoidance
 (FLTA) 175
 Freezing Levels 157
 Fuel Calculations 92
 Fuel Flow Calibration 93
 Fuel Remaining 92

G

GDL 60 270–272 271–272
 Geodetic Sea Level (GSL) 168 172 174
 GFC 500 204 205 207 221 227 230
 Glidepath Mode (GP) 217
 Glove Qualification 273 279 280 281
 282 283 284

H

Horizon Headings 256

I

Icing 158

L

Land Symbols 99

M

Map
 Orientation 115
 Map Symbols 307

N

Navigation Database 286
 Negative Climb Rate (NCR) 175
 NEXRAD 152 153 154
 Non-Threat Traffic 188 192 196

- O**
 Obstacle Database 287
 Orientation 115
- P**
 Pop-up Alert 273 274
 Premature Descent Alert (PDA) 175
 Proximity Advisory (PA) 192 196
- R**
 Radar Altimeter
 Test 248
 Registration 24
 Reversionary 12
- S**
 SafeTaxi 241
 SafeTaxi Database 286
 Selected Altitude 213 215
 Selected Altitude Capture Mode 213
 215 219
 Selected Heading 220 221
 SiriusXM Weather
 Cell Movement 156
 Cloud Tops 156
 County Warnings 158
 Freezing Level 157
 NEXRAD 152
 Surface Analysis 159
 Winds Aloft 151
 Stormscope 166 167
 Supercooled Large Droplet (SLD) 158
 Surface Analysis 156 159 165
 Symbols 307
 Synthetic Vision Technology (SVT) 255
 Display Features 256
 Terrain and Obstacle Alerting 259
 Traffic 260
 Troubleshooting 261
 System ID 24
- System Messages 275
- T**
 TAWS-B 173
 Temporary Flight Restrictions (TFRS) 152
 Terrain
 Alerts 174
 Configurations 168
 Inhibit 177
 Legend 172 174
 Test 179
 View 172
 Wire Obstacles 171
 Terrain Database 287
 Terrain Proximity 173
 Time Stamp 162
 Track Vector 111
 Traffic
 Alerts 185
 Altitude Filtering 183
 Configurations 181
 Status Icon 184
 Target Selection 184
 Traffic Advisory System (TAS) 196 197
 198
 Traffic Advisory (TA) 188 192 196
 Traffic Alert and Collision Avoidance
 System (TCAS) 196 197 198
 Traffic Information Service (TIS) 187
 189
 Traffic Page 183
 Annunciations 187
 Turbulence 160
- W**
 Warning 94 95 273
 Waypoints
 Information 131
 Weather Product Age 161 162 163

Weather Products

Enabling/Disabling 164

Legend 165

Winds Aloft 151 165

WireAware 169 171

Wireless 36

Y

Yaw Damper 199

Z

Zero Pitch Line 256



Garmin International, Inc.

1200 East 151st Street
Olathe, KS 66062, U.S.A.

Garmin AT, Inc.

2345 Turner Road SE
Salem, OR 97302, U.S.A.

Garmin (Europe) Ltd.

Liberty House, Hounsdown Business Park
Southampton, Hampshire SO40 9LR U.K.

Garmin Corporation

No. 68, Zhangshu 2nd Road
Xizhi District, New Taipei City, Taiwan

Contact Garmin Product Support or view warranty information at flygarmin.com.

